

Project Submittal Package



Project:

Location:

Architect:

General Contractor:

Applicator:



Master Wall Inc.®



[System Data Sheets](#) [Product Data Sheets](#) [Sample Warranty](#)
[Specifications](#) [Details](#) [Web Link \(click here\)](#)

PO Box 397

Fortson

GA

31808

800-755-0825

masterwall.com



Master Wall Inc.
Building a Culture of Excellence

ROLLERSHIELD DRAINAGE CIFS® 12

Rollershield Drainage CIFS® 12 steps up our standard system with Primecoat Primer for better looks and weather protection. It features high weather and air protection along with high R-value continuous insulation board.

The system offers the designer a full spectrum of finish options from our standard Superior Finishes to specialty finishes.

Features & Benefits

- 12-year limited warranty
- Durable and efficient SuperiorShield Rollershield Air/Water Barrier
- Cost effective Master Wall Insulation Board
- Class leading Master Wall Standard Mesh with Medium Impact Resistance
- Primecoat Primer for improved looks

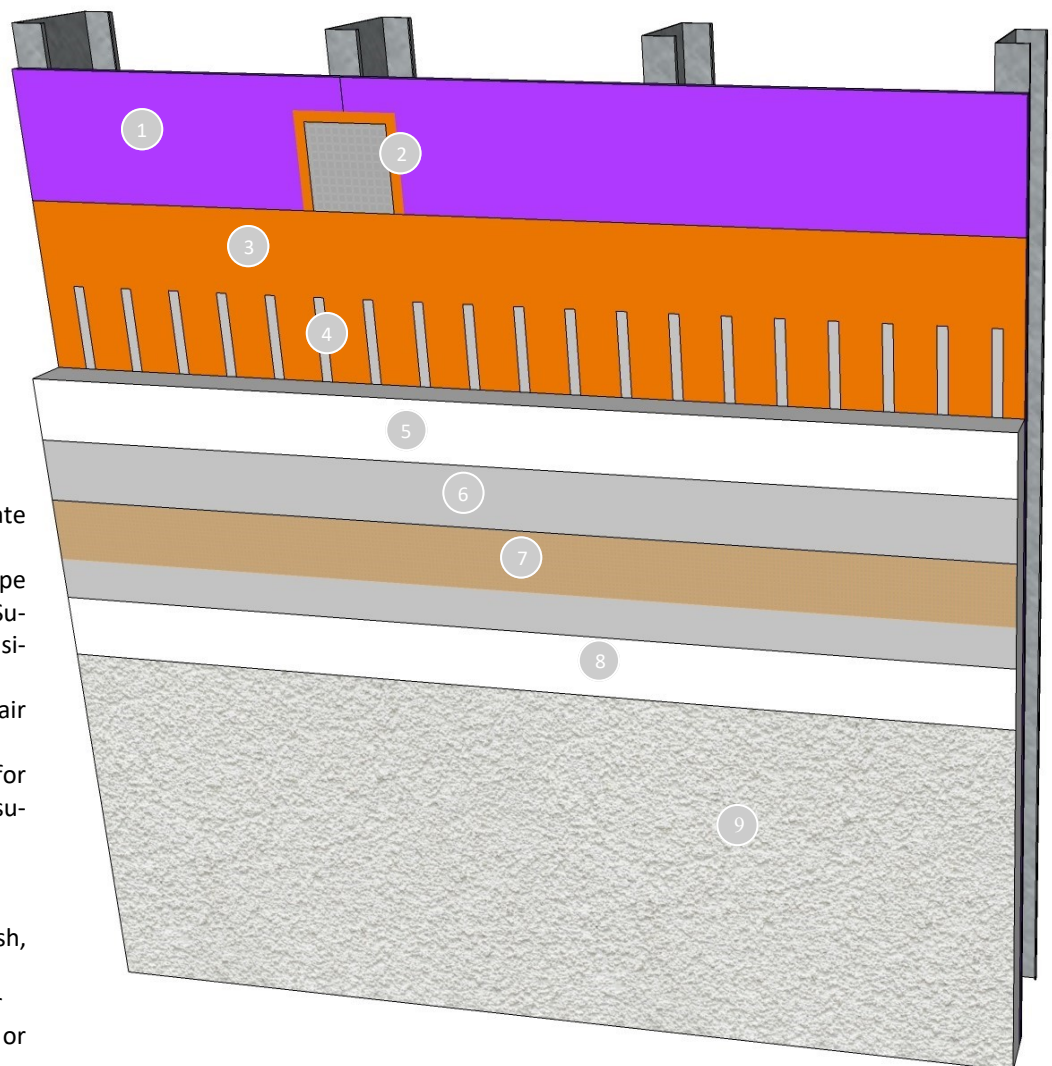

1. Framing & Approved Substrate (by others)
2. SuperiorShield Flashing Tape embedded in Rollershield or SuperiorFlash at seams and transitions
3. SuperiorShield Rollershield air and water barrier
4. Vertical Notched Channels for drainage and to adhere the insulation board
5. Master Wall® Insulation Board
6. Master Wall® Base Coat
7. Master Wall® Aggre-flex Mesh, embedded in base coat
8. Master Wall® Primecoat Primer
9. Master Wall® Superior Finish or Specialty Finish

Short Form Specification

1.0 General

This is a short form specification. Refer to Rollershield Drainage CIFS® specifications and details for additional information.

1.1 System Description

The Master Wall® Rollershield Drainage Continuously Insulated Finish System (CIFS®) is a Class PB (Polymer Based) EIF System consisting of a roll-applied water barrier, vertical channel adhesive attachment, insulation board, reinforcing mesh and a textured finish.

1.2 Design Requirements:

- A. Reference Master Wall® suggested details and architectural drawings for specific detail requirements.
- B. Slope all surfaces a recommended minimum of 1:2 (6" in 12") to shed water, maximum 12" (305 mm) wide.
- C. Maximum deflection of substrates shall not exceed L/240.
- D. Typical acceptable substrates include unpainted brick, masonry, concrete, Portland cement plaster (stucco), exterior grade gypsum sheathing (ASTM C1396), Glass Fiber Sheathing (ASTM C1177), CDX exterior grade plywood, Exposure 1 Oriented Strand Board (OSB).
- E. Expansion joints are required in the cladding at building expansion joints, panel joints, floor lines in wood framed construction, and other areas where significant movement occurs.

1.3 Quality Assurance

- A. The Rollershield Drainage System shall be recognized by local building codes.
- B. The system shall meet or exceed ASTM C1397 and detailed in accordance with ASTM E2511.
- C. The system shall have been tested for fire performance in accordance with ASTM E108, ASTM E-84, NFPA 265, and NFPA 268.
- D. The system shall have been tested for drainage performance in accordance with ASTM E331.

1.4 Job Conditions

- A. Store all materials protected from weather and direct sunlight at temperatures above 40oF (5oC).
- B. The ambient and wall temperature shall be a minimum of 40oF (5oC) and shall remain so for at least 24 hours after installation.

1.5 Warranty

- A. Master Wall Rollershield Drainage CIFS® 12-year limited warranty.

2.0 Products

All components of the Rollershield Drainage System shall be manufactured by Master Wall® and supplied by an authorized distributor.

A. SuperiorShield Water Barrier & Flashing Tapes:

- SuperiorShield Rollershield (RS): A 100% pure acrylic-based roll-applied weather-resistive barrier.
- SuperiorShield Trowel Grade (TG): A 100% pure acrylic-based trowel grade water-resistive barrier.
- SuperiorShield Flashing Tape: A lightweight nonwoven joint treatment material.

B. Master Wall Adhesives:

1. Foam & Mesh Adhesive (F&M), F&M Plus: A 100% pure acrylic-based adhesive that is field mixed with Portland cement.
2. Master Wall® Bagged Base (MBB), MBB Plus: A ready to use dry base that is field mixed with water.

C. Insulation Boards: Master Wall® Insulation Board.

D. Aggre-flex Mesh: Available in Standard, Detail, Hi-Tech, Medium, Strong and Ultra. Minimum Standard Mesh required.

E. Master Wall Base Coats:

1. Foam & Mesh Adhesive (F&M), F&M Plus.
2. Master Wall® Bagged Base (MBB), MBB Plus.

F. Primecoat: 100% pure acrylic primer.

G. Superior Finish: 100% pure acrylic formulation with integral color and texture. Perfect Swirl 2.0, Fine Sand 1.0, Medium Sand 1.5, Versatex 0.5 textures.

3.0 Installation

- A. Inspect the substrate to ensure that it is free of all foreign materials that would affect the adhesion of the Rollershield Drainage CIFS® System.
- B. Apply the system in strict accordance with Master Wall® specifications, product data sheets, architectural drawings and architectural specifications using the products noted above.

Information contained in this product data sheet conforms to the standard detail recommendations and specifications for the installation of Master Wall Inc.® products and is presented in good faith. Master Wall Inc.® assumes no liability, expressed or implied as to the architecture, engineering, or workmanship of any project. This information may be concurrent with, or superseded by other applicable documents, such as specifications and details. Contact Master Wall Inc.® for the most current product information. ©2025 Master Wall Inc.®





Master Wall Inc.®
Building a Culture of Excellence

PRODUCT DATA

SUPERIORSHIELD ROLLERSHIELD-RS

SuperiorShield Rollershield-RS is a high quality 100% acrylic flexible fluid applied air and water barrier that is easily applied with a roller or spray equipment but also can be troweled or brushed into place. Rollershield-RS forms a continuous air and water barrier that protects approved substrates from incidental water damage.

FEATURES & BENEFITS

- Used as an air/water barrier in Rollershield LAB applications or as part of the Rollershield Drainage CIFS® System
- 100% Coverage, Fully adhered to substrate
- Vapor open/permeable with low air infiltration rate
- Used as water barrier and flashing, 60-minute Grade D equivalent
- Compatible with other SuperiorShield products; Rollershield-TG (Trowel Grade), Rollershield-VB, SuperiorFlash and WeatherSTOP Tape
- Adheres to most common building materials
- Easy to apply, water based for easy cleanup
- Exposure up to 6 months
- Low VOC, <1% by weight, 10 g/L

Application Temperature: 25° -110°F (-3.8° -43°C)

Dry to Touch: 1 hour @ room temperature

Recoat Time: 2 hours @ room temperature

Drying Time: 12 hours @ room temperature, working and drying time will vary with temperature and humidity.

JOB CONDITIONS

Air and substrate temperature for application of Rollershield-RS must be 40°F (5°C) or higher and must remain 40°F (5°C) or higher for a minimum of 24 hours unless special procedures are used. Provide temporary protection to protect the wall system from damage until permanent flashings, caps and sealants are installed. Store materials within prescribed temperature limits and out of direct sunlight. Working and drying times are based upon normal room temperature conditions and will vary with temperature and humidity.

PREPARATION

The substrate must be approved by Master Wall Inc.®, clean, dry, structurally sound, and free of efflorescence, oil, grease, form release agents and curing compounds or anything that would affect bond. Painted surfaces are not acceptable and must be removed or bond test performed. Substrates must be flat and free of fins or planar irregularities greater than 1/4" in 10'-0" (6.35 mm in 3.05 m).

Coverage per pail (sf/sm)*

Roller: 450-500 sf (42-46 sm)

Spray: 300-350 sf (28-32.5 sm)

Trowel: 200-250 sf (18-23 sm)

**All coverage is approximate for a single coat of 15 mils wet film thickness (WFT), 10 mils dry and depend upon substrate, details and individual application*

Packaging/Shelf Life/Storage

Packaging: 5 gallon (19L) pail

Product Color: Naranja Durazno

Shelf Life: 2 years

Storage: Protect from extreme heat: 90°F (32°C), freezing and direct sunlight.

APPLICATION PROCEDURE

Concrete – Must have cured a minimum of 28 days prior to the application of Rollershield-RS. If form release agents or curing compounds exist on the surface, they must be removed with a solution of muriatic acid or similar product (with appropriate precautions). Remove any residual acid by flushing with water.

Brick/Masonry – If joints are not struck flush, multiple coats may be required. Porous CMU may require additional coats.

Sheathing Applications - Sheathing gaps must be less than 1/4" (6.4 mm). See Technical Bulletin #189 for larger gap suggestions. Gap wood-based sheathing per manufacturers recommendations, typically 1/8" (3.2 mm) minimum.

Mixing - Thoroughly stir Rollershield-RS into a homogenous consistency. Do not add water, over mix, or add accelerators or retarders to the product.

Application – Rollershield-RS is applied by first treating the joints and fastener locations where sheathing is used, then coating the entire surface using brush, roller, trowel, or airless spray equipment techniques. When using a foam roller, a maximum 3/4" (19 mm) nap is recommended. Apply in an even, continuous coat, maintaining a wet edge of approximately 15 mils wet film thickness (WFT). Oriented Strand Board and other porous substrates will require two (2) coats of Rollershield-RS. For moisture protection, apply Rollershield-RS as a continuous barrier of 10 mils dry thickness with no breaks or skips, although some areas will appear lighter than others due to the application process. The application need not look like a painted surface.

Joint Treatment—Apply a thin layer of Rollershield-RS to the joints and embed SuperiorShield Flashing Tape into the wet mixture and trowel smooth. Alternatively place and center SuperiorShield Mesh over all joints, corners, and gaps in the substrate. Immediately apply Rollershield-RS over the mesh and allow to dry.

Rollershield-RS may be flashed into window, door and other openings using the same techniques for sheathing applications. Any remaining gaps should be filled with additional Rollershield-RS, TG (Trowel Grade) or SuperiorFlash.

Wall Treatment—Apply Rollershield-RS to the wall surface using the foam roller, trowel or by spray applying and backrolling to a uniform thickness of 15 mils WFT, 10 mils dry with no pinholes or voids.

Hazard: This chemical is not considered hazardous according to the OSHA Hazard Communication Standard 2012 (29 CFR 1910.1200).

Approved Substrates

Exterior gypsum sheathing (ASTM C1396)

Glass Fiber Exterior Sheathing (ASTM C1177): Dens Glass Gold®, GlasRoc®, FiberBond®, Gold Bond e2xp®, etc.

Cement Board Substrates (ASTM C1325): Durock®, PermaBase®, ProTEC®, SelectCrete, Util-A-Crete®, etc.

Concrete

Brick

Masonry

Exterior Plywood

Oriented Strand Board (OSB)

Huber Zip (See Data Sheet for Specifics)

Most metals and PVC

Others approved in writing

Compatible SuperiorShield Components

Rollershield-TG

SuperiorFlash

SuperiorShield Flashing Tape

SuperiorShield Mesh

WeatherSTOP Tape

Sealant Bond Compatibility**

Adfast Corp.: Adseal DWSP1940 Series***, Adseal 4600, Adseal 4580, Adseal 1940

Dow Corning: 795 Silicone**

Pecora Corp.: 864NST, 890NST, 890FTS, 895NST^A, Dynatrol I-XL Hybrid^B

Sika: Silaflex 15 LM***, Silaflex-2C NS***

Master Builders Solutions: MasterSeal NP1***

Tremco: Dymonic 100***

Most polyurethane sealants**

See Technical Bulletin MW#131 for latest sealant information

**field verify bond (varies)

***Also bonds to SuperiorFlash

^AWith P120 Primer with Rollershield RS & TG

^BWith P120 Primer with Rollershield VB

SPECIALTY APPLICATION - MEDIUM AND HIGH BUILD

Application for Medium-Build Specification: apply one or two coats to achieve minimum 20 mils wet film thickness (WFT). If applied by roller apply two coats to achieve minimum 20 mils WFT. For CMU substrates apply two or three coats to achieve 20-60 mils WFT.

Application for High-Build Specification: apply two or three coats to achieve 40 mils WFT. If applied by roller apply three or more coats as needed. For CMU substrates apply multiple coats to achieve 40-60 mils WFT.

IMPORTANT: the condition of the substrate may dictate thicker application or more coats to achieve a VOID and PINHOLE FREE SURFACE, particularly on substrates like concrete masonry where CMU composition, unit weight (lightweight or normal weight), porosity, joint profile, and other variables may exist. For “rough” CMU wall surfaces level with Master Wall Base Coat before applying the coating. Use the mock-up and site tests as the basis for the work. Some highly absorbent glass mat gypsum sheathing substrates may require back rolling to achieve a VOID and PINHOLE FREE surface. Avoid excess film build-up of wet material to prevent sag, especially on non-porous surfaces and during cold or damp weather. Work away from sun during application.

SPECIALTY APPLICATION - COLD WEATHER

Special Instruction for Cold Temperature Application: Master Wall Rollershield may be applied at temperatures less than 40° down to 25° F (4° down to -3.8°C), provided certain conditions are met:

1. Pre-condition Rollershield-RS to 65°-75° F (18°-24° C) for a minimum of 24 hours.
2. Confirm and maintain substrate and ambient temperatures are minimum 25° F (-3.8°C) and rising at the time of application and do not fall below 25° F (-3.8°C) until Rollershield-RS is fully dry.
3. Apply Rollershield-RS over standard sheathing substrates – glass mat gypsum, plywood, or OSB.
4. Confirm substrate surfaces are frost-free, dry and remain dry throughout the application and curing process.
5. Apply Rollershield-RS at a wet film thickness of no greater than 15 mils WFT.
6. Apply Rollershield-RS with Master Wall SuperiorShield Flashing Tape for joint and rough opening treatments.
7. Apply in dry weather and protected from rain or other precipitation for at least 24 hours and relative humidity (RH) remains at or below 50%. **IMPORTANT:** Final water-resistive barrier and air barrier material properties, and film toughness, depend on temperatures rising above freezing.

COLD WEATHER LIMITATIONS

Application range is at ambient temperatures between 25° and 100° F (-3.8° and 38° C) during application and drying period. Strictly adhere to Special Instructions for Cold Temperature Application if installing below 40° F (4° C).

Do not apply if substrate or ambient temperature is less than 25° F (-3.8°C), or if temperatures will go below 25° F (-3.8°C) at any time during the application or drying period.

Do not apply if the surface temperature is less than 5° F (2.8°C) above the ambient dew point temperature.

Technical Data

Solids Content: 69.52% solids by wt (55.05% by volume)

Tensile Bond, ASTM C297/E2134/AC212: 30-200 psi

Freeze-thaw ASTM E2485/AC212: Pass

Water Resistance, ASTM D2247/AC212: Pass

Water Vapor Transmission, ASTM E96 Proc. B/AC212: 30 perms** @ 10 mils, 15 perms @ 20 mils

Air Permeance, ASTM E2178: 0.001 cfm/ft² @ 1.57 psf, 0.001 L/s/m² @ 75 Pa

Air Leakage, ASTM E2357: 0.0006 cfm/ft² @ 1.57 psf (0.003 L/s/m² @ 75 Pa), 0.04 cfm/ft² @ 6.24 psf (0.02 L/s/m² @ 300 Pa)

Structural Performance, ASTM E1233/AC212: Pass

Racking, ASTM E72/AC212: Pass

Restrained Environmental, AC212: Pass

Water Penetration, ASTM E331/AC212: Pass

UV Exposure: Rated to 6 months

Accelerated Aging, AC212: Pass

Hydrostatic Pressure Test, AATCC 127/AC212: Pass

Surface Burning Characteristics, ASTM E84: Flame Spread < 25, Smoke Developed < 450

Intermediate Multi-Story Fire Test, NFPA 285 (UBC 26-9): Pass

Nail Sealability, ASTM D1970: Pass @ 22 mils

Heat and Smoke Release Rates, ASTM E1354, IBC Section 1403.5: Peak Heat Release Rate = 32 kW/m², Total Heat Release Rate = 3.6 MJ/m², Effective Heat of Combustion = 2.5 MJ/kg

** Defined as a Class III vapor retarder per IBC and IRC

LIMITATIONS

Not for use as an exterior finish, note exposure limitations on front page.

When adhering Rollershield Drainage CIFS® to the surface assure it is clean, dry, and free of surface contamination. Remove any dirt or surface contamination before adhesive attachment.

Allowable in-service temperature range: -40° to 180° F (-40° to 82° C).

Fire-retardant or pressure treated plywood must be dry with surface free of salts or other chemicals migrating from within the wood. Test adhesion to be sure of desired results.

Use a slip sheet, typically one layer of building paper between Rollershield-RS and stucco or adhered masonry veneer over metal lath.

SPRAY APPLICATION

Rollershield-RS is compatible with GRACO and Titan airless spray equipment with the following specifications:

- Minimum 1 gallon per minute output.
- Minimum hose width of 3/8 inch.
- Minimum tip size of 0.027–0.031.

Minimum pressure requirement to spray of 2,000 psi at the gun with an airless sprayer rated no lower than 3,300 psi. Remove all filters in sprayer and gun before application.

Hopper Gun: 3/16"-1/4" (6-6.5 mm) orifice, 23-25 psi.

CLEAN UP

Tools and equipment can be cleaned with soapy water when Rollershield-RS is wet.

Information contained in this product data sheet conforms to the standard detail recommendations and specifications for the installation of Master Wall Inc.® products and is presented in good faith. Master Wall Inc.® assumes no liability, expressed or implied as to the architecture, engineering, or workmanship of any project. This information may be concurrent with, or superseded by other applicable documents, such as specifications and details. Contact Master Wall Inc.® for the most current product information. ©2023 Master Wall Inc.®

Health & Safety

WARNING!

Causes eye and skin irritation.

Precautionary Statement

Wash hands thoroughly after handling. Wear protective gloves/protective clothing/eye protection/face protection.

FIRST AID MEASURES

Eye: Contact Rinse thoroughly with water as necessary. Get medical attention immediately if symptoms occur.

Skin: Contact Wash off with water. Consult a physician if necessary.

Inhalation: Move to fresh air. If symptoms arise, call a physician.

Ingestion: Clean mouth with water and afterwards drink plenty of water. Do NOT induce vomiting.

Consult a physician. Never give anything by mouth to an unconscious person.

Store locked up. Dispose of contents/container in accordance with Local, State, Federal and Provincial regulation.

Spills: Collect with suitable absorbent material such as cotton rags.

Disposal: Dispose of in accordance with local, state or federal regulations.

Warning: KEEP CONTAINER CLOSED WHEN NOT IN USE. KEEP OUT OF THE REACH OF CHILDREN. NOT FOR INTERNAL CONSUMPTION. FOR INDUSTRIAL USE ONLY.

Consult the Safety Data Sheet (SDS) in the Products section at masterwall.com for further health and safety information.

LIMITED WARRANTY

This product is subject to a written limited material or system warranty. Obtain a warranty from the Tech Support tab of our website. Refer to Specifications for more complete information on proper use and handling of this product.



Master Wall Inc.
Building a Culture of Excellence

PRODUCT DATA

SUPERIORSHIELD FLASHING TAPE

Lightweight non adhesive roll flashing material with superior strength and the ability to bridge most gaps or voids common in construction. Embedded into wet Rollershield-RS, TG or VB, it is used at flashing transitions with Master Wall® SuperiorShield Liquid Air/Water Barrier (LAB) and as part of Rollershield Drainage CIFS® applications. The tape easily embeds into wet Rollershield and dries to a highly reinforced yet flexible flashing.

FEATURES & BENEFITS

- Lightweight
- Strong
- Embeds easily
- Thin, will not build up wall surface
- Compatible with Rollershield RS, TG, VB and SuperiorFlash products

JOB CONDITIONS

Air and substrate temperature for application of SuperiorShield Flashing Tape must be 40°F (5°C) or higher. Follow Rollershield-RS, TG or VB temperatures and condition requirements.

PREPARATION

General—The substrate must be clean, dry, structurally sound, and free of efflorescence, oil, grease, form release agents and curing compounds. Test painted surfaces to verify bond.

Temporary Protection – Protect from weather until the Rollershield-RS, TG or VB products have set up.

Surface Preparation - Surface temperature must be above 40°F (5°C). Surface must be cured, clean, dry, structurally sound, and free of efflorescence, oil, grease, form release agents, and curing compounds.

Coverage estimate*

4x8 sheets: Square Footage x 0.37 = linear feet of tape

Add linear footage around windows, doors, and other openings.

**All coverage is approximate and depend upon substrate, details and individual application*

Roll Sizing/Packaging/Shelf Life/Storage

4"x180' (10.2cm x 54.9m)

6"x180' (15.2cm x 54.9m)

9"x180' (22.9cm x 54.9m)

Packaging:

4": 18 rolls per case.

6" & 9": 12 rolls per case.

Shelf Life: 2 years plus

Storage: Protect from extreme heat (90°F (32°C)), and direct sunlight.

APPLICATION PROCEDURE

General - SuperiorShield Flashing Tape is embedded into wet Rollershield-RS, TG or VB at flashing transitions (sheathing to framing, flashing, penetrations, etc.) and at sheathing board joints. Apply a generous layer of the product using a trowel, brush or roller and immediately embed the SuperiorShield Flashing Tape into the product and draw it tight and smooth working from the center to the edges.

Windows – The unique properties of the SuperiorShield air/water barrier system allows window flashing prior to the Rollershield wall application. Apply Rollershield and center SuperiorFlash Flashing Tape to provide at least at least 1” (25 mm) bond to the window flange and substrate on either side of the window opening. Use a “butterfly” at corners to complete the application making sure it covers all corner joints. For best results make sure the Rollershield covers the entire head, jamb, and sill areas. The use of sill wedges or water stops is encouraged.

Sheathing Applications – Apply Rollershield at least 2” (51 mm) either side of the sheathing board joint. Immediately embed the SuperiorShield Flashing Tape into the wet Rollershield and smooth with a trowel, centering it over the joint. Provide at least at least 1” (25 mm) bond either side of the sheathing joint. Lap Rollershield Mesh Tape 2” (51 mm) minimum Rollershield field application can begin as soon as the Rollershield is dry to the touch.

Information contained in this product data sheet conforms to the standard detail recommendations and specifications for the installation of Master Wall Inc.® products and is presented in good faith. Master Wall Inc.® assumes no liability, expressed or implied as to the architecture, engineering, or workmanship of any project. This information may be concurrent with, or superseded by other applicable documents, such as specifications and details. Contact Master Wall Inc.® for the most current product information. ©2022 Master Wall Inc.®



Hazard: This chemical is not considered hazardous according to the OSHA Hazard Communication Standard 2012 (29 CFR 1910.1200).

VOC: Less than 50 g/L.

Approved Materials for Embedment

Rollershield-RS
Rollershield-TG
Rollershield-VB
Others approved in writing

LIMITED WARRANTY

This product is subject to a written limited material or system warranty. Obtain a warranty from the Tech Support tab of our website. Refer to Specifications for more complete information on proper use and handling of this product.

220701



Master Wall Inc.®
Building a Culture of Excellence

PRODUCT DATA

MASTER WALL® INSULATION BOARD – TYPE I

Master Wall® Insulation Board is a high performance insulation material that is used to wrap the entire building to keep interior temperatures more consistent. It helps to reduce thermal bridging at framing members and is easy to cut, rasp and place. It may be custom formed into various decorative shapes. Packaged in 144 board foot bundles, each bundle weights approximately 12 lbs. (5.44 kg) and is available in flat or drainage configurations.

FEATURES & BENEFITS

- Continuous Insulation for Wall Assemblies - CIFS® & EIFS
- Easily cut into shapes for decorative trim
- Reduces air movement in wall
- Reduces life cycle CO2 emissions
- Controls dew point / moisture condensation in wall
- Long lasting, strong, stable
- Contains no CFC, HCFC, HFC or formaldehyde
- Recyclable
- Cost effective

TECHNICAL DATA

- Meets or Exceeds ASTM C578, ASTM C273, ASTM E2430, ASTM E2568.
- ASTM C578, Type I, Wall Specification Grade
- Minimum Density: 0.90 pcf
- R-Value (U-Value) at 75°F (9°C): 3.8 (0.28) per inch thickness
- Compressive strength, min., PSI (kPa): 10.0 (69)
- Tensile strength min., PSI (kPa): 15.0 (103)
- Flexural Strength, min., PSI (kPa) : 25.0 (172)
- Water Vapor Permeance of 1.00 in (25.2 mm) thickness, max., perm (ng/Pa.s.m²): 5.0 (287)
- Water absorption by total immersion, max., volume, % : 4.0
- Dimensional stability (change in dimensions), max., %: 2.0
- Oxygen index, min., volume, %: 24.0
- Flame spread, max.: 25.0
- Smoke development, max. 450
- For a full listing of approved manufacturers please reference the insulation board page at masterwall.com

Packaging/Storage

144 board foot bundles* wrapped in plastic. Store on jobsite protected from the elements

Board Thickness & Size

Typical Maximum 4" (102 mm)
Minimum 3/4" (19.1 mm)
Drainage Board 1.5" (38.2 mm)+

Board width, max.: 24" (610 mm)
Board length, max.: 48" (1219 mm)

Coverage by Typical Thickness

3/4" (19.2 mm):
24 pcs, 192 sf (17.84 m²)

1" (25.2 mm):
18 pcs, 144 sf (13.38 m²)

1-1/2" (38.2 mm):
12 pcs, 96 sf (8.92 m²)

2" (50.8 mm):
9 pcs, 72 sf (6.69 m²)

3" (76.2 mm):
6 pcs, 48 sf (4.46 m²)

4" (101.6 mm):
5 pcs, 40 sf (3.72 m²)

*Varies by manufacturer facility

APPLICATION PROCEDURE

Job Conditions - Follow directions on adhesive data sheets. Mechanical attachment of insulation boards may be performed at lower temperatures over a dry surface.

Temporary Protection – Provide temporary and permanent protection to prevent water entry behind the system.

Substrate Preparation – Applications must be to an approved substrate with a maximum variation tolerance of 1/4" in 10'-0" (6.4 mm in 3.05 m). Contact Master Wall for approved substrates and recommended attachment methods.

Application

The Insulation Board can be easily cut using handsaws, power saws, sharp knives, or thermal cutting tools. Rasping of the Insulation Board is completed with 12 grit sandpaper, manually or with air or electric rasping machines.

Follow data sheet recommendations for adhering insulation board to approved substrates. For mechanical attachment, fasten the Insulation Board to the approved substrate using Wind-Lock Wind-Devil 2 or other approved plastic plates. See Master Wall System Details for more information. Fastening patterns shall be determined by the requirements of the geographical conditions of the area, local code requirements, and the performance of the fasteners, retainers and their test results in conjunction with the specified substrate and the thickness of insulation board specified for use. Minimum 1" (25.2 mm) thickness for mechanically attached systems.

Install insulation board on the wall according to specification requirements. For further information and details, see the Master Wall System Application Instructions.

LIMITATIONS

The minimum required thickness for insulation board in the Master Wall Aggre-flex EIF System and Rollershield Drainage CIFS® is 3/4" (19.2 mm) at any location on the wall. This minimum is required under aesthetic joints as well.

Insulation board shall not be used in interior applications.

Residential applications require a secondary water barrier with the option of flat insulation board with profiled water barriers or drainage insulation board. See Aggre-flex Drainage Details for insulation board construction.

Product description information and basic uses etc.

Information contained in this product data sheet conforms to the standard detail recommendations and specifications for the installation of Master Wall Inc.® products and is presented in good faith. Master Wall Inc.® assumes no liability, expressed or implied as to the architecture, engineering, or workmanship of any project. This information may be concurrent with, or superseded by other applicable documents, such as specifications and details. Contact Master Wall Inc.® for the most current product information. ©2024 Master Wall Inc.®





Master Wall Inc.®
Building a Culture of Excellence

PRODUCT DATA

F&M ADHESIVE AND BASE COAT

Foam & Mesh Adhesive (F&M) is a 100% acrylic formulated high performance base coat and adhesive used in Master Wall® Systems or over prepared substrates including brick, masonry, concrete and stucco.

FEATURES & BENEFITS

- Adheres insulation board to approved substrates
- Base coat for Master Wall CIFS®, EIFS and other Systems
- Leveling coat for Cemplaster Fiberstucco and other stucco products
- Excellent water resistance
- Mixes 1:1 with Portland cement to a creamy consistency
- 100% Acrylic Polymers for durability
- Water-based - easy clean up with water

Application Temperature: 40°-110°F (5°-43°C)

Working Time: 1 hour

Set Time: Varies with temperature and humidity

Dry Time: 12 hours at room temperature, working and drying time will vary with temperature and humidity.

JOB CONDITIONS

Air and substrate temperature for application of F&M must be 40°F (5°C) or higher and must remain 40°F (5°C) or higher for a minimum of 24 hours. Provide temporary protection to protect the wall system from damage until permanent flashings, caps and sealants are installed. Store materials within prescribed temperature limits and out of direct sunlight. Working and drying times are based upon normal room temperature conditions and will vary with temperature and humidity.

PREPARATION

The substrate must be approved by Master Wall Inc.®, clean, dry, structurally sound and free of efflorescence, oil, grease, form release agents and curing compounds or anything that would affect bond. Painted surfaces are generally unacceptable without evaluation. Reference Technical Bulletins #173 and #187 for additional information.

Coverage per pail (sf/sm)*

Adhesive & Standard Base Coat:
120 sf (11 sm)

Embedding Single-layer of Mesh:
240-280 sf (22-26 sm)

Double Layer of Mesh:
80-230 sf (7.5-21 sm)

Notched Trowel Adhesive Application:
135 sf (12.5 sm)

**All coverage is approximate and depend upon substrate, details and individual application*

Packaging/Shelf Life/Storage

Packaging: 5 gallon (19L) pail

Pail Weight: 60 lbs (27 kg)

Shelf Life: 2 years

Storage: Protect from extreme heat - 90°F (32°C) and above, freezing and direct sunlight.

Technical Data

ASTM C297/E2134 - min 30 psi (208 kPa)

ASTM D897 - min 22 psi (152 kPa) ASTM
D2247 - Pass

ASTM E84 - Pass

ASTM E96 - 12 perms

ASTM E331 - Pass to 12.0 psf (575 Pa)

ASTM E2485/EIMA 101.01* - Pass NFPA
268* - Pass

NFPA 285 (UBC 26-9)* - Pass

*part of a larger assembly

APPLICATION PROCEDURE

Mixing - Thoroughly stir F&M using a heavy duty 1/2" (12.7 mm) drill at 400 to 500 rpm and a heavy duty mixing paddle. Pour half of the stirred F&M into a clean plastic pail. Add Type I or I-II Portland cement to the half pail of F&M in a ratio of one-to-one by weight and mix to a homogenous consistency. Let the mixture stand for 3 to 5 minutes and then stir to a creamy consistency. Up to 30 ounces (0.9L) of clean, potable water may be added to a half pail to adjust workability. Do not over mix as faster setting or reduced working time can occur. Do not add accelerators or retarders to the F&M mixture.

APPLICATION

ADHESIVE APPLICATION – Over gypsum or Rollershield coated substrates, apply the F&M mixture directly to the back of the insulation board using a 3/8" x 3/8" x 3/8" (9.5 x 9.5 x 9.5 mm) or a 3/8" x 1/2" x 1-1/2" (9.5 x 13 x 38 mm) stainless steel notched trowel. With the trowel at a 45-degree angle, cover the entire back of the insulation board with full beads of adhesive. Apply the adhesive so the ribbons run vertically when applied to the wall.

Over non-gypsum substrates where drainage is not required, you may use the above described notched trowel method or the 'ribbon and dab' method. Using a stainless steel plastering trowel, apply a 2" (50.8 mm) wide by 3/8" (9.5 mm) high ribbon of the F&M mixture around the entire perimeter of the insulation board. Place 8 dabs of the F&M mixture 3/8" (9.5 mm) thick by 4" (102 mm) in diameter approximately 8" (204 mm) on center inside the ribbon.

Immediately place the prepared insulation board on the substrate. Make sure that all edges of the insulation board are abutted tightly and that no F&M mixture gets into the board joints. Do not allow the F&M mixture to form a skin prior to placing the insulation board on the substrate. Do not apply the F&M mixture directly onto the substrate.

BASE COAT APPLICATION – Over insulation board, all imperfections in the board must be rasped flush and any gaps in the insulation board must be filled with slivers of insulation. Apply the F&M mixture over the entire surface of the insulation board in a thickness greater than that of the reinforcing fabric being used (approximately 1/16" (1.6 mm) for standard mesh and 3/32" (2.4 mm) for Ultra Mesh). Immediately embed the reinforcing fabric into the wet F&M mixture and smooth from the center to the edge to avoid wrinkles. The reinforcing fabric must be continuous at all corners and lapped or abutted in accordance with Master Wall® specifications. The color of the mesh shall not be visible, but a slight mesh pattern may be visible.

As a leveling coat over approved concrete, masonry, stucco, and other surfaces, apply the F&M mixture over the entire surface a nominal 1/16" (1.6 mm) thick. Where reinforcing mesh is specified, follow application methods for insulation board above.

Hazard: This chemical is not considered hazardous according to the OSHA Hazard Communication Standard 2012 (29 CFR 1910.1200).

VOC: Less than 50 g/L.

Approved Substrates

Exterior gypsum sheathing
(ASTM C1396, C1177)
Dens Glass Gold®
GlasRoc®
FiberBond®
Gold Bond e2xp®
Securock®
Weather Defense Platinum™
Cement Board (ASTM C1325)
Durock®
PermaBase®
Util-A-Crete®
ProTEC®, ProGUARD®
Concrete
Brick
Masonry
Metal Lath - Adhesive Application
Adheres to Rollershield
Others approved in writing

CLEAN UP

Tools and equipment can be cleaned with soapy water while the F&M is still wet.

WARNING, THIS PRODUCT CONTAINS SILICA

If sanding or scraping are performed, ventilate work area and/or use a NIOSH/MSHA-approved respirator in accordance with our Safety Data Sheet.

Information contained in this product data sheet conforms to the standard detail recommendations and specifications for the installation of Master Wall Inc.® products and is presented in good faith. Master Wall Inc.® assumes no liability, expressed or implied as to the architecture, engineering, or workmanship of any project. This information may be concurrent with, or superseded by other applicable documents, such as specifications and details. Contact Master Wall Inc.® for the most current product information. ©2022 Master Wall Inc.®

**Health & Safety****WARNING!**

Causes eye and skin irritation.
Precautionary Statement

Wash hands thoroughly after handling. Wear protective gloves/protective clothing/eye protection/face protection.

FIRST AID MEASURES

Eye Contact: Immediately flush eyes with plenty of water for at least 15 to 20 minutes. Ensure adequate flushing of the eyes by separating the eyelids with fingers. Get immediate medical attention.

Skin Contact: Immediately wash skin with plenty of soap and water for 15 to 20 minutes, while removing contaminated clothing and shoes. Get medical attention if irritation develops or persists.

Inhalation: If inhaled, remove to fresh air. If not breathing, give artificial respiration or give oxygen by trained personnel. Seek immediate medical attention.

Ingestion: If swallowed, do NOT induce vomiting. Call a physician or poison control center immediately. Never give anything by mouth to an unconscious person.

Storage: Store locked up. Dispose of contents/container in accordance with Local, State, Federal and Provincial regulation.

Spills: Collect with suitable absorbent material such as cotton rags.

Disposal: Dispose of in accordance with local, state or federal regulations.

Warning: KEEP CONTAINER CLOSED WHEN NOT IN USE. KEEP OUT OF THE REACH OF CHILDREN. NOT FOR INTERNAL CONSUMPTION. FOR INDUSTRIAL USE ONLY.

Consult the Safety Data Sheet (SDS) in the Products section at masterwall.com for further health and safety information.

LIMITED WARRANTY

This product is subject to a written limited material or system warranty. Obtain a warranty from the Tech Support tab of our website. Refer to Specifications for more complete information on proper use and handling of this product.



Master Wall Inc.[®]
Building a Culture of Excellence

PRODUCT DATA

MBB

Master Wall® Bagged Base Coat (MBB) is a dry polymer acrylic formulated high performance base coat and adhesive used in Master Wall® Systems or over prepared substrates including brick, masonry, concrete and stucco.

FEATURES & BENEFITS

- Adheres insulation board to approved substrates
- Base coat for Master Wall CIFS®, EIFS and other Systems
- Leveling coat for Cemplaster Fiberstucco and other stucco products
- Excellent water resistance
- Freeze stable in dry form
- Convenient, mixes with water
- Easy clean up with water

Application Temperature: 40°-110°F (5°-43°C)

Working Time: 1 hour

Set Time: Varies with temperature and humidity

Dry Time: 12 hours at room temperature, working and drying time will vary with temperature and humidity.

JOB CONDITIONS

Air and substrate temperature for application of MBB must be 40°F (5°C) or higher and must remain 40°F (5°C) or higher for a minimum of 24 hours. Provide temporary protection to protect the wall system from damage until permanent flashings, caps and sealants are installed. Store materials within prescribed temperature limits and out of direct sunlight. Working and drying times are based upon normal room temperature conditions and will vary with temperature and humidity.

PREPARATION

The substrate must be approved by Master Wall Inc®., clean, dry, structurally sound and free of efflorescence, oil, grease, form release agents and curing compounds or anything that would affect bond. Painted surfaces are generally unacceptable without evaluation. Reference Technical Bulletins #173 and #187 for additional information.

Coverage per bag (sf/sm)*

Adhesive & Standard Base Coat:

50-60 sf (4.6-5.36 sm)

Embedding Single-layer of Mesh:

100-125 sf (9-11.5 sm)

Double Layer of Mesh:

30-110 sf (2.5-10 sm)

Notched Trowel Adhesive Application:

56 sf (5.2 sm)

**All coverage is approximate and depend upon substrate, details and individual application*

Packaging/Shelf Life/Storage

Packaging: 50lb (22.7kg) bag

Shelf Life: 1 year

Storage: Protect from weather, high humidity and direct sunlight.

Technical Data

ASTM C297/E2134 - min 30 psi (208 kPa)

ASTM E96 - 12 perms

APPLICATION PROCEDURE

Mixing - Add 5 to 6 quarts (4.7-5.7L) of potable water to a clean plastic pail. Add the MBB slowly while stirring using a heavy-duty 1/2" (12.7mm) drill at 400 to 500 rpm and a heavy-duty Mixer. Mix thoroughly to a homogenous consistency. Let the mixture stand for 3 to 5 minutes and then stir to a creamy consistency. Small amounts of clean, potable water may be added to obtain a workable consistency. Do not over mix. Excessive stirring may cause faster setting and reduced working time. Do not add accelerators or retarders to the MBB mixture.

APPLICATION

ADHESIVE APPLICATION – Over gypsum or Rollershield coated substrates, apply the MBB mixture directly to the back of the insulation board using a 3/8" x 3/8" x 3/8" (9.5 x 9.5 x 9.5 mm) or a 3/8" x 1/2" x 1-1/2" (9.5 x 13 x 38 mm) stainless steel notched trowel. With the trowel at a 45-degree angle, cover the entire back of the insulation board with full beads of adhesive. Apply the adhesive so the ribbons run vertically when applied to the wall.

Over non-gypsum substrates where drainage is not required, you may use the above described notched trowel method or the 'ribbon and dab' method. Using a stainless steel plastering trowel, apply a 2" (50.8 mm) wide by 3/8" (9.5 mm) high ribbon of the F&M mixture around the entire perimeter of the insulation board. Place 8 dabs of the F&M mixture 3/8" (9.5 mm) thick by 4" (102 mm) in diameter approximately 8" (204 mm) on center inside the ribbon.

Immediately place the prepared insulation board on the substrate. Make sure that all edges of the insulation board are abutted tightly and that no F&M mixture gets into the board joints. Do not allow the MBB mixture to form a skin prior to placing the insulation board on the substrate. Do not apply the MBB mixture directly onto the substrate.

BASE COAT APPLICATION – Over insulation board, all imperfections in the board must be rasped flush and any gaps in the insulation board must be filled with slivers of insulation. Apply the MBB mixture over the entire surface of the insulation board in a thickness greater than that of the reinforcing fabric being used (approximately 1/16" (1.6 mm) for standard mesh and 3/32" (2.4 mm) for Ultra Mesh). Immediately embed the reinforcing fabric into the wet MBB mixture and smooth from the center to the edge to avoid wrinkles. The reinforcing fabric must be continuous at all corners and lapped or abutted in accordance with Master Wall® specifications. The color of the mesh shall not be visible, but a slight mesh pattern may be visible.

As a leveling coat over approved concrete, masonry, stucco, and other surfaces, apply the MBB mixture over the entire surface a nominal 1/16" (1.6 mm) thick. Where reinforcing mesh is specified, follow application methods for insulation board above.

Hazard: This chemical is not considered hazardous according to the OSHA Hazard Communication Standard 2012 (29 CFR 1910.1200).

VOC: Less than 50 g/L.

Approved Substrates

Exterior gypsum sheathing
(ASTM C1396, C1177)

Dens Glass Gold®

GlasRoc®

FiberBond®

Gold Bond e2xp®

Securock®

Weather Defense Platinum™
Cement Board (ASTM C1325)

Durock®

PermaBase®

Util-A-Crete®

ProTEC®, ProGUARD®

Concrete

Brick

Masonry

Metal Lath - Adhesive Application

Adheres to Rollershield

Others approved in writing

CLEAN UP

Tools and equipment can be cleaned with soapy water while the MBB is still wet.

WARNING, THIS PRODUCT CONTAINS SILICA

If sanding or scraping are performed, ventilate work area and/or use a NIOSH/MSHA-approved respirator in accordance with our Safety Data Sheet.

Information contained in this product data sheet conforms to the standard detail recommendations and specifications for the installation of Master Wall Inc.® products and is presented in good faith. Master Wall Inc.® assumes no liability, expressed or implied as to the architecture, engineering, or workmanship of any project. This information may be concurrent with, or superseded by other applicable documents, such as specifications and details. Contact Master Wall Inc.® for the most current product information. ©2022 Master Wall Inc.®



Health & Safety

WARNING!

Causes eye and skin irritation.

Precautionary Statement

Wash hands thoroughly after handling. Wear protective gloves/protective clothing/eye protection/face protection.

FIRST AID MEASURES

Eye Contact: Immediately flush eyes with plenty of water for at least 15 to 20 minutes. Ensure adequate flushing of the eyes by separating the eyelids with fingers. Get immediate medical attention.

Skin Contact: Immediately wash skin with plenty of soap and water for 15 to 20 minutes, while removing contaminated clothing and shoes. Get medical attention if irritation develops or persists.

Inhalation: If inhaled, remove to fresh air. If not breathing, give artificial respiration or give oxygen by trained personnel. Seek immediate medical attention.

Ingestion: If swallowed, do NOT induce vomiting. Call a physician or poison control center immediately. Never give anything by mouth to an unconscious person.

Storage: Store locked up. Dispose of contents/container in accordance with Local, State, Federal and Provincial regulation.

Spills: Collect with suitable absorbent material such as cotton rags.

Disposal: Dispose of in accordance with local, state or federal regulations.

Warning: KEEP CONTAINER CLOSED WHEN NOT IN USE. KEEP OUT OF THE REACH OF CHILDREN. NOT FOR INTERNAL CONSUMPTION. FOR INDUSTRIAL USE ONLY.

Consult the Safety Data Sheet (SDS) in the Products section at masterwall.com for further health and safety information.

LIMITED WARRANTY

This product is subject to a written limited material or system warranty. Obtain a warranty from the Tech Support tab of our website. Refer to Specifications for more complete information on proper use and handling of this product.



Master Wall Inc.®
Building a Culture of Excellence

PRODUCT DATA

AGGRE-FLEX MESH

Master Wall® Aggre-flex Mesh is a specially woven, glass fiber mesh with AR Coating (Alkali Resistive). Embedded in Master Wall® base coats, Aggre-flex Mesh is the key impact and tensile component in Master Wall® EIFS and wall systems. It can also improve crack resistance in Master Wall® Cemplaster Fiberstucco Systems, traditional stucco or foam shapes.

FEATURES & BENEFITS

- **Detail Mesh** – super soft, pliable mesh used for backwrapping, special shapes, and detail work.
- **Standard Mesh**–Standard weight mesh for wall areas and general detailing. Industry leading impact resistance.
- **Hi-Tech Mesh**–Upgraded heavier weight version of Standard Mesh with good workability.
- **Medium Mesh**–Extra tough heavy weight mesh. Best for areas of light traffic.
- **Strong Mesh**–Great high traffic mesh where impacts are a consideration.
- **Ultra Mesh**–Best where abuse is expected. Ultra heavy for high traffic areas.
 - **Strong Mesh and Ultra Mesh** must be used in a two-layer system.
- **Corner Roll**– For highly impact resistant corners. Apply under Standard or higher mesh.

MESH WEIGHT AND COVERAGE

	Mesh Weight	Roll Size	Coverage*
Detail	4.5 oz/sy (113 g/sm)	9.5" x 150' (96.5cm x 45.7m)	119 sf (11 sm)
Standard - 38	4.6 oz/sy (156 g/sm)	38" x 150' (96.5cm x 45.7m)	475 sf (44.1 sm)
Standard - 48	4.6 oz/sy (156 g/sm)	48" x 150' (122 cm x 45.7m)	600 sf (55.7 sm)
Hi-Tech	6.0 oz/sy (202 g/sm)	48" x 150' (122cm x 45.7m)	600 sf (55.7sm)
Medium	11.0 oz/sy (370 g/sm)	38" x 75' (96.5cm x 22.8m)	238 sf (22.1 sm)
Strong	15.4 oz/sy (508 g/sm)	38" x 75' (96.5cm x 22.8m)	238 sf (22.1 sm)
Ultra	21.0 oz/sy (700 g/sm)	48" x 75' (122cm x 22.8m)	300 sf (22.1 sm)
Corner Roll	9.5 oz/sy (238 g/sm)	9.5" x 150' (96.5cm x 45.7m)	150 lf (45.7 m)

*Allow about 10% waste for lapping all meshes (Strong, Ultra and Corner Roll Meshes are butted). Coverage will vary.

PRODUCT TEST STANDARDS

ASTM D76, ASTM D578, ASTM D579, ASTM D1777, ASTM D3659, ASTM D3775, ASTM D3776, ASTM D4029, ASTM D5035, ASTM E2098, ASTM E2486. MIL-Y-1140

Weave: Full Leno

Impact ASTM E2486 (Formerly EIMA 101.86)

ASTM D5035 Tensile (warp/fill)

Standard Mesh	Medium Impact Resistance 50-89 in-lbs (5.7-10.1J)	247/280
Hi Tech Mesh	Medium Impact Resistance 50-89 in-lbs (5.7-10.1J)	140/250
Medium Mesh	Medium Impact Resistance 50-89 in-lbs (5.7-10.1J)	300/500
Medium & Standard	High Impact Resistance 90-150 in-lbs (10.2-17.0J)	300/500
Strong & Standard	Ultra High Impact Resistance 150+ in-lbs (over17.0J)	350/600
Ultra & Standard	Ultra High Impact Resistance 150+ in-lbs (over17.0J)	750/500
Corner Roll		274/274

APPLICATION PROCEDURE

Job Conditions - Air and substrate temperature for embedment of the Reinforcing Mesh must be 40°F (5°C) or higher and must remain 40°F (5°C) or higher for a minimum of 24 hours. Provide temporary protection at all times until the wall system, including flashings, caps, and sealants, is completed to provide protection from climatic conditions and other potential damage.

Application - All imperfections in the insulation board must be rasped flush and any gaps in the insulation board must be filled with slivers of insulation. Apply the base coat over the entire surface of the insulation board in a thickness greater than that of the Reinforcing Mesh being used, approximately 1/16" (1.6 mm) for Standard Mesh and 3/32" (2.4 mm) for Ultra Mesh. Immediately embed the Aggre-flex Mesh into the wet base coat and smooth from the center to the edge to avoid wrinkles. Lap all meshes except Strong Mesh and Ultra Mesh a minimum of 2-1/2" (63.5 mm) on all sides. The reinforcing fabric must be continuous at all corners and lapped or abutted in accordance to Master Wall specifications. The color of the mesh shall not be visible but a slight mesh pattern may be visible. The overall minimum thickness of the base coat should be a nominal 1/16" (1.6 mm) when dry.

When applying Strong, Ultra or Corner Roll Mesh, tightly abut all edges and let cure for a minimum of 12 hours. Grind any imperfections with the edge of a stainless steel trowel or grinding stone, taking care not to damage the Aggre-flex Mesh, and apply a layer of Standard Mesh, Hi-Tech Mesh, or Medium Mesh as per the directions in the preceding paragraph. To minimize wall variations, the lap of the second mesh layer should not coincide with the abutment of the first layer.

Special Conditions and Recommendations

Apply wrapping, backwrapping mesh or other approved accessory at all terminations of the insulation board. This includes at the top and bottom of all walls and at all openings.

Aggre-flex Mesh may be wrapped from the face of the insulation board onto a foundation or onto the studs of an opening on barrier wall systems. In all cases, the exposed edges of the insulation board must be wrapped with Aggre-flex Mesh and base coat or an approved accessory trim.



Health & Safety

WARNING!

Causes eye and skin irritation.

Precautionary Statement

Wash hands thoroughly after handling. Wear protective gloves/protective clothing/eye protection/face protection.

Consult the Safety Data Sheet (SDS) in the Products section at masterwall.com for further health and safety information.

LIMITED WARRANTY

This product is subject to a written limited material or system warranty. Obtain a warranty from the Tech Support tab of our website. Refer to Specifications for more complete information on proper use and handling of this product.

Information contained in this product data sheet conforms to the standard detail recommendations and specifications for the installation of Master Wall Inc.® products and is presented in good faith. Master Wall Inc.® assumes no liability, expressed or implied as to the architecture, engineering, or workmanship of any project. This information may be concurrent with, or superseded by other applicable documents, such as specifications and details. Contact Master Wall Inc.® for the most current product information.

©2022 Master Wall Inc.®



Master Wall Inc.
Building a Culture of Excellence

PRODUCT DATA

PRIMECOAT PRIMER

High quality exterior acrylic primer that helps solidify and protect the surface. Integrally colored Primecoat Primer helps make finishes brighter and deeper, reduces efflorescence and extends finish coverage rates. Suitable for priming Master Wall® base coats, new stucco, masonry and concrete that has a pH of 13 or less.

FEATURES & BENEFITS

- Tintable sealer/primer with good hiding power
- Hot prime capable for pH 13 or less
- Reduces finish absorption for improved aesthetics and reduced finish color variations
- Recommended for extreme color changes, under very dark, vivid or bright topcoats or when top tier finishing is specified
- Extends finish coverage, required when spraying Superior Finishes and some specialty finishes
- 100% Acrylic Polymers for durability
- Water-based - easy clean up with water

Application Temperature: 40°-110°F (5°-43°C)

Dry to touch: 1 hour

Recoat Time: 2 hours

Dry Time: 12 hours at room temperature, working and drying time will vary with temperature and humidity.

JOB CONDITIONS

Air and substrate temperature for application of Primecoat must be 40°F (5°C) or higher and must remain 40°F (5°C) or higher for a minimum of 24 hours. Provide temporary protection to protect the wall system from damage until permanent flashings, caps and sealants are installed. Store materials within prescribed temperature limits and out of direct sunlight. Working and drying times are based upon normal room temperature conditions and will vary with temperature and humidity.

PREPARATION

The substrate must be approved by Master Wall Inc.®, clean, dry, structurally sound and free of efflorescence, oil, grease, form release agents and curing compounds or anything that would affect bond. Concrete and masonry should be cured a minimum of 28 days, stucco cured a minimum of 7-14 days or surfaces verified to have a pH less than 13.

Coverage per pail (sf/sm)*

1000-1200 sf/pail (93-112 sm)*

**All coverage is approximate and depend upon substrate, details and individual application*

Packaging/Shelf Life/Storage

Packaging: 5 gallon (19L) pail Pail

Shelf Life: 2 years

Storage: Protect from extreme heat - 90°F (32°C), freezing and direct sunlight.

Technical Data

Water Vapor Transmission (perms), ASTM E96 Vapor Permeable

Substrate Recommendations

Concrete – If preparing for a textured or specialty finish, all projections must be removed and any voids filled with a Master Wall® base coat as needed to provide an appropriate surface.

Masonry – If preparing for a textured or specialty finish, skim coat with a Master Wall® base coat to achieve a smooth level surface. If joints are not struck flush, multiple coats may be required. Contact Master Wall for more information.

Stucco – If additives were used in the stucco, it is recommended that a test patch be made to evaluate bond strength of the Primecoat to the stucco.

Master Wall® Base Coats or Finishes, Previously Painted Surfaces, Cement Composition Siding

Install/Apply and prepare according to published guidelines. Surfaces should be clean, dry, cured and ready to receive coatings.

APPLICATION PROCEDURE

Mixing - Thoroughly stir Primecoat into a homogeneous consistency. Small amounts of clean, potable water may be added to obtain a workable consistency. Do not over mix. Do not exceed 24 ounces (0.7L) of water per pail. Do not add accelerators or retarders to Primecoat.

Application - Primecoat can be applied by brush, roller, or airless spray equipment. When using a roller, a maximum 3/4" (19 mm) nap is recommended. Apply Primecoat in an even, continuous coat of about 3 mils, maintaining a wet edge.

Airless Spray Application - Pressure 2000 p.s.i., Tip .015- to .019 inch. Spray in a consistent manner or backroll after spraying for a consistent application.

Limitations - Primecoat is not intended for use as the final finish coat over Master Wall base coats or other approved substrates.

FOR PROFESSIONAL RESULTS

Apply coatings away from direct sunlight. Cold joints or color variations can occur if the finish dries too quickly. Under certain conditions dark colors may show efflorescence on the surface during the cure process.

Surfaces exposed to the weather must be sloped (6:12 minimum). Use of dark colors in high temperature climates can affect the performance of the system, especially EIFS and areas may need to be limited.

CLEAN UP

Tools and equipment can be cleaned with soapy water when Primecoat is wet.

Hazard: This chemical is not considered hazardous according to the OSHA Hazard Communication Standard 2012 (29 CFR 1910.1200).

VOC: Less than 50 g/L.

Approved Substrates

Master Wall® Base Coats
Stucco
Brick
Masonry
Concrete
Interior Drywall
Previously painted surfaces with bond test
Others approved in writing

Warning: KEEP CONTAINER CLOSED WHEN NOT IN USE. KEEP OUT OF THE REACH OF CHILDREN. NOT FOR INTERNAL CONSUMPTION. FOR INDUSTRIAL USE ONLY.

Consult the Safety Data Sheet (SDS) in the Products section at masterwall.com for further health and safety information.

LIMITED WARRANTY

This product is subject to a written limited material or system warranty. Obtain a warranty from the Tech Support tab of our website. Refer to Specifications for more complete information on proper use and handling of this product.

Information contained in this product data sheet conforms to the standard detail recommendations and specifications for the installation of Master Wall Inc.® products and is presented in good faith. Master Wall Inc.® assumes no liability, expressed or implied as to the architecture, engineering, or workmanship of any project. This information may be concurrent with, or superseded by other applicable documents, such as specifications and details. Contact Master Wall Inc.® for the most current product information. ©2022 Master Wall Inc.®



Master Wall Inc.®
Building a Culture of Excellence

PRODUCT DATA

SUPERIOR FINISHES

To finish strong you need a Superior Finish. Master Wall® finishes are crafted with one of the highest 100% acrylic polymer contents in our industry. This translates to extra durability, lower life-cycle maintenance and a longer lasting finish.

FEATURES & BENEFITS

- 100% Acrylic Polymers for durability
- Dirt Pickup Resistant (DPR) Polymer Formulation
- Quartz or Marble aggregate available
- 64 Standard Colors
- Custom color matching available
- DuroTone colorfast pigments, Excel mildew enhancement, Silicone Coat additive available
- Vapor Permeable - resists blistering and allows trapped water vapors to pass
- Low VOC—Suitable for Interior Use
- Water Based - easy clean up with water

Application Temperature: 40°-110°F (5°-43°C)

Working Time: 1/4 hr

Set Time: 8-12 hrs

Dry Time: 48-72 hrs at room temperature, working and drying time will vary with temperature and humidity.

JOB CONDITIONS

Air and substrate temperature for application of Superior Finishes must be 40°F (5°C) or higher and must remain 40°F (5°C) or higher for a minimum of 24 hours. Provide temporary protection to protect the wall system from damage until permanent flashings, caps and sealants are installed. Store materials within prescribed temperature limits and out of direct sunlight. High temperatures will reduce working times, Low temperatures and/or high humidity and pigment loading will extend working, set and dry times.

PREPARATION

The substrate must be approved by Master Wall Inc.®, clean, dry, structurally sound and free of efflorescence, oil, grease, form release agents and curing compounds or anything that would affect bond. Painted surfaces are not acceptable and must be removed. Concrete and surfaces should cure for a minimum of 28 days. Stucco should be cured until clean, dry and hard—typically 14 days with a pH of 10 or less (13 or less if Primecoat Primer is used).

Interior drywall should be finished and made ready for paint. Prime surfaces with Primecoat/Sanded Primecoat primer prior to finishing.

Coverage per pail (sf/sm)*

- Perfect Swirl 2.0, 120-150 (11-14)
- Fine Sand 1.0, 160-170 (15-15.8)
- Medium Sand 1.5, 130-150 (12-14)
- Versatex 0.5, Varies with Texture

**All coverage is approximate and depend upon substrate, details and individual application*

Packaging/Shelf Life/Storage Packaging:

- 5 gallon (19L) pail Pail

Shelf Life: 2 years

Storage: Protect from extreme heat (90°F, 32°C), freezing and direct sunlight.

Technical Data

ASTM B117 Salt Spray Resistance - Pass ASTM

C67 Freeze/Thaw - Pass

ASTM C297 Tensile Bond - 30 psi minimum

ASTM D968 Abrasion Resistance - Pass 500L

ASTM D2247/E2570 Water Resistance - Pass

ASTM D3273 Mildew Resistance - Pass 28 Days

ASTM E84 Surface Burning - Pass, FS=0, SD=0

ASTM E 96 Vapor Permeability - Pass, 12 perms, vapor open

ASTM E108 Flame Propagation - Pass

ASTM E2485/2570 (formerly EIMA 101.01)

Impact Resistance - Pass

ASTM G23/G154/G155 Accelerated Weathering - Pass 2000 Hours

ASTM G53 Accelerated Weathering - Pass 2000 Hours

APPLICATION PROCEDURE

Base Coats - Must be flat, dry hard, and free of efflorescence. Master Wall® base coats must cure a minimum of 12 hours before application of Superior Finish. Substrates of brick, masonry or concrete should be leveled smooth using either Master Wall® base coats or stucco.

Mixing - Thoroughly stir Superior Finish using a heavy duty 1/2" drill at 400 - 500 rpm and a heavy duty mixing paddle. Small amounts of clean, potable water may be added to obtain a workable consistency. To avoid color variations, add the same amount of water to each pail. Do not exceed 24 ounces (0.7L) of water per pail of finish.

Application - Apply a uniform thickness (about 1/16", 1.6 mm) of Superior Finish to the substrate using a stainless steel trowel. Spread evenly and then scrape the finish coat down to a thickness no greater than the largest aggregate in the material. Immediately float the finish coat using a plastic float to the desired texture. Always maintain a wet edge to achieve uniformity of texture and color. Allow the finish to fully dry and set before exposure to inclement weather.

FOR PROFESSIONAL RESULTS

Apply finish coats away from direct sunlight. Cold joints or color variations can occur if the finish dries too quickly. Priming stucco surfaces with Primecoat/Sanded Primecoat evens out finish absorption and should be strongly considered and specified for dark colored finishes, especially those using Ultra Deep Base (UDB) tint base and over stucco to avoid efflorescence blush. Under certain conditions dark colors may show efflorescence on the surface during the cure process.

Surfaces exposed to the weather must be sloped (6:12 minimum). Use of dark colors in high temperature climates can affect the performance of the system, especially EIFS and areas may need to be limited.

Deep, intense colors should be specified with DuroTone pigments to maintain colorfastness longer. Verify specialty colors with your Master Wall® Distributor. Finishes are intended for the approved substrates listed above and should not be applied directly to gypsum board or insulation board products.

CLEAN UP

Tools and equipment can be cleaned with soapy water while the Superior Finish is still wet.

Hazard: This chemical is not considered hazardous according to the OSHA Hazard Communication Standard 2012 (29 CFR 1910.1200).

VOC: Less than 50 g/L.

See Superior Finishes for other technical properties

Approved Substrates

Master Wall® Base Coats
Cemplaster Fiberstucco, One Coat Stucco (OCS), Primecoat Primer surfaces, ASTM C926 Stucco

Prepared & Base Coated Surfaces of:
Brick, Concrete, Masonry
Others approved in writing

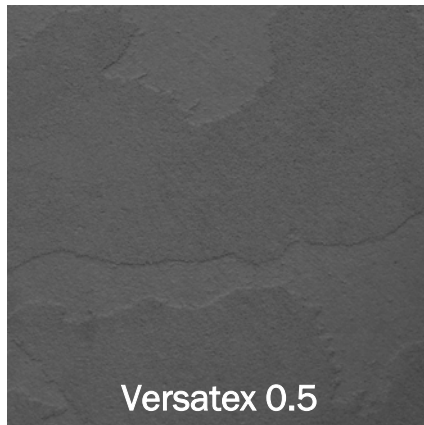
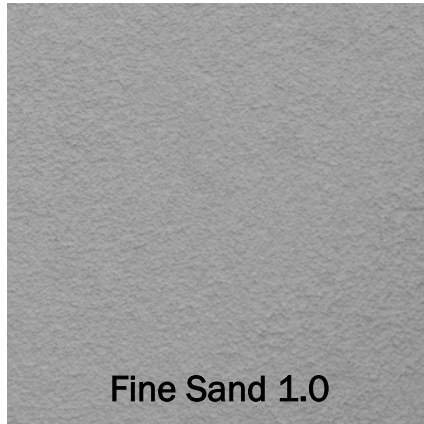

Information contained in this product data sheet conforms to the standard detail recommendations and specifications for the installation of Master Wall Inc.® products and is presented in good faith. Master Wall Inc.® assumes no liability, expressed or implied as to the architecture, engineering, or workmanship of any project. This information may be concurrent with, or superseded by other applicable documents, such as specifications and details. Contact Master Wall Inc.® for the most current product information. ©2022 Master Wall Inc.®



Health & Safety

WARNING!

Causes eye and skin irritation.
 Precautionary Statement
 Wash hands thoroughly after handling. Wear protective gloves/protective clothing/eye protection/face protection.

FIRST AID MEASURES

Eye Contact: Immediately flush eyes with plenty of water for at least 15 to 20 minutes. Ensure adequate flushing of the eyes by separating the eyelids with fingers. Get immediate medical attention.

Skin Contact: Immediately wash skin with plenty of soap and water for 15 to 20 minutes, while removing contaminated clothing and shoes. Get medical attention if irritation develops or persists.

Inhalation: If inhaled, remove to fresh air. If not breathing, give artificial respiration or give oxygen by trained personnel. Seek immediate medical attention.

Ingestion: If swallowed, do NOT induce vomiting. Call a physician or poison control center immediately. Never give anything by mouth to an unconscious person.

Store locked up. Dispose of contents/container in accordance with Local, State, Federal and Provincial regulation.

Spills: Collect with suitable absorbent material such as cotton rags.

Disposal: Dispose of in accordance with local, state or federal regulations.

Warning: KEEP CONTAINER CLOSED WHEN NOT IN USE. KEEP OUT OF THE REACH OF CHILDREN. NOT FOR INTERNAL CONSUMPTION. FOR INDUSTRIAL USE ONLY.

Consult the Safety Data Sheet (SDS) in the Products section at masterwall.com for further health and safety information.

LIMITED WARRANTY
 This product is subject to a written limited material or system warranty. Obtain a warranty from the Tech Support tab of our website. Refer to Specifications for more complete information on proper use and handling of this product.



Master Wall Inc.®
Building a Culture of Excellence

**SAMPLE
WARRANTY**

Rollershield Drainage CIFS® 12 Year Labor & Material Limited Warranty

Master Wall Inc.® warrants the properly designed and installed Rollershield Drainage Continuous Insulation and Finish System (CIFS®) and materials for 12 years from the date of installation. Master Wall Inc.®'s exclusive liability under this warranty is to supply replacement materials and labor or corrective procedures, if it is shown that the materials supplied by Master Wall Inc.®, were defective when installed by the Master Wall Inc.® certified applicator. Remedies shall be solely determined by Master Wall Inc.® and no other warranties are expressed or implied. For a valid warranty, the system and products must be installed in accordance with Master Wall Inc.® written recommendations, specifications, details, bulletins and other project-specific written recommendations. Master Wall Inc.® must be notified in writing within 10 business days of the original discovery of the defect.

Master Wall Inc.®, is not responsible for structural conditions, design conditions beyond those noted in our literature, architecture, engineering or workmanship of any project. Drainage Systems are warranted to drain incidental water for the warranty period. Materials must be properly stored and applied in a timely manner. Workmanship, aesthetics and installation are beyond the scope of this warranty as are any deviations from Master Wall Inc. Documents not specifically approved in writing.

Abuse, misuse, excessive weather or environmental conditions beyond what the products or systems have been tested, designed or approved for is expressly limited. Certain colors with organic pigments are less fade-resistant than others. The building, system and products must be properly maintained in accordance with Master Wall Inc.®, documents, local environmental conditions and good building practices. In no case is Master Wall Inc.® responsible for incidental and consequential damages.

This warranty becomes effective only when all bills for the components of the system have been paid.

Except as stated, Master Wall, Inc.®, expressly disclaims any warranty of merchantability or fitness for a particular purpose. The above remedies are to be deemed exclusive.



Master Wall Inc.®
Building a Culture of Excellence

This is not the final warranty. For a valid warranty fill out a warranty request under Tools and Technical at masterwall.com. Warranties are not valid until issued.

PRODUCT AND SYSTEM TESTING



Master Wall Inc.®
Building a Culture of Excellence



MASTER WALL® SYSTEMS SPECIFICATION FACT SHEET

- Manufacturer of EIFS, Stucco and Coatings since 1987
- Committed and focused specifically on our industry; privately held and American owned.
- Pioneer in CIFS® (Continuous Insulation and Finish Systems)
- Leader in specialty finishes; CIFS® Wood Grain, CIFS® Brick, Hydrophobic Finishes, Metallics, SuperiorCote coatings
- AWCI Certified EIFS Professional (CEP) accredited Sales and Technical Force
- AIA MasterSpec listed, AIA CES Registered Provider
- Industry Leadership
 - EIMA (EIFS Industry Members Association) – Manufacturer Member and Current President
 - NOCSA (National One Coat Stucco Association) – Manufacturer Member and Current President
 - SMA (Stucco Manufacturer's Association) – Manufacturer Member and Board Member
 - ABAA (Air Barrier Association of America) – Manufacturer Member
 - AWCI (Association of the Wall and Ceiling Industry) – Member
 - FWCCA (Florida Wall & Ceiling Contractors Association) – Member
- Code Compliant EIFS, CIFS® Stucco and Air Barrier Systems (ICC, Miami Dade and Florida Building Code recognized systems)
- Full-service product support including sales and technical aspects of your project
- Labor and Material Limited Warranties exceeding other manufacturers ranging up to 20 years including Single-source envelope warranties with approved Sealant manufacturers.
- DuroTone High Performance Tint Pigments for Improved Color Retention (5-year fade warranty)
- Manufacturing strategically located in Stonecrest GA, Brookshire TX and Payson UT
- Nationwide distributor network that serves most major markets



Master Wall Inc. continuously tests our products and systems to meet the most current building codes.

FIRE TESTING			
Test	Test Method	Criteria	Results
Fire Resistance	ASTM E119	No effect on the fire resistance of a rated wall assembly	See Technical Bulletin MW#168-030111 for assemblies
Ignitability	NFPA 268 (BOCA 99/1407.0)	No ignition at 12.5 kw/m ² at 20 minutes	Pass
Intermediate Multi-Story Fire Test	NFPA 285 (UBC 26-9)	<ol style="list-style-type: none"> 1. Resist flame propagation over the exterior surface 2. Resist vertical spread of flame within combustible core/component of panel from one story to the next 3. Resist vertical spread of flame over the interior surface from one story to the next 4. Resist lateral spread of flame from the compartment of fire origin to adjacent spaces 	Pass
Surface Burning Characteristics— Base Coat, Mesh and Finish	ASTM E84	All components shall have a: Flame Spread < 25 Smoke Developed < 450	Flame Spread = 0 Smoke Developed = 0
Surface Burning Characteristics— Rollershield	ASTM E84	All components shall have a: Flame Spread < 25 Smoke Developed < 450	Flame Spread = 5 Smoke Developed = 5
Heat and Smoke Release Rates for Rollershield Air/ Water Barrier	ASTM E1354, IBC Section 1403.5, Exception 2 Requirements	Peak Heat Release Rate <150 kWm ² Total Heat Release Rate <20 MJ/m ² , Effective Heat of Combustion <18 MJ/kg	RS: Peak Heat Release Rate = 32 kWm ² , Total Heat Release Rate = 3.6 MJ/m ² , Effective Heat of Combustion = 2.5 MJ/kg, VB: Peak Heat Release Rate = 336 kWm ² , Total Heat Release Rate = 8.8 MJ/m ² , Effective Heat of Combustion = 9.3 MJ/kg

MESHERS AND INSULATION BOARD			
Test	Test Method	Criteria	Results
Reinforcing Mesh Alkali Resistance of Reinforcing Mesh	ASTM E2098 (formerly EIMA 105.01)	>21dN/cm (120 pli) retained tensile strength after exposure	Pass
EPS (Physical Properties)			
Density	ASTM C303, D1622	15.2-20.0 kg/m ³ (0.95-1.25 lb/ft ³)	Pass
Thermal Resistance	ASTM C177, C518	4.0 @ 4.4 °C (40 °F)	Pass
Water Absorption	ASTM C272	3.6 @ 23.9 °C (75 °F)	
Oxygen Index	ASTM D2863	2.5 % max. by volume	Pass
Compressive Strength	ASTM D1621 Proc. A	24% min. by volume	Pass
Flexural Strength	ASTM C203	69 kPa (10 psi) min.	Pass
Flame Spread	ASTM E84	172 kPa (25 psi) min.	Pass
Smoke Developed		25 max. 450 max.	Pass Pass



EIFS & COATING

Test	Test Method	Criteria	Results
Abrasion Resistance	ASTM D968	No deleterious effects after 500 liters (528 quarts)	Pass
Accelerated Weathering	ASTM G155 Cycle 1	No deleterious effects after 2000 hours	Pass
Accelerated Weathering	ASTM G23 (G152 & 153)	No deleterious effects after 2000 hours	Pass
Accelerated Weathering	ASTM G53	No deleterious effects after 2000 hours (QUV)	Pass
Freeze-Thaw	ASTM E2485 (formerly EIMA 101.01)	No deleterious effects after 60 cycles	Pass
Freeze-Thaw	ASTM C67 modified/ICBO AC24	No deleterious effects after 10 cycles	Pass
Freeze-Thaw	ASTM E2485/ICC-ES Proc. ICC ES (AC 235)***	No deleterious effects after 10 cycles	Pass
Mildew Resistance	ASTM D3273	No growth during 28 day exposure period	Pass
Water Resistance	ASTM D2247	No deleterious effects after 14 days exposure	Pass
Impact	ASTM D5420	Gardner Impact Falling Weight	Pass
Salt Spray Resistance	ASTM B 117	No deleterious effects after 300 hours exposure	Pass
Water Penetration	ASTM E331 ICC ES (AC 235)***	No water penetration beyond the inner-most plane of the wall after 15 minutes at 137 Pa (2.86 psf)	Pass at 2.86 psf (137 Pa), 6.24 psf (299 Pa), and 12.0 psf (575 Pa) consecutively
Water Vapor Transmission	ASTM E 96 Water Method	Vapor permeable perm (ng/Pa.s.m ²)	EPS 5 perm-inch (114) Base Coat* 12 (679) Finish** 12 (674)
Component-Specific Weather Protection	IBC 1403	2-hour water test of EIFS and specific components	Pass
Drainage Efficiency	ASTM E 2273 ICC ES (AC 235)***	Minimum Drainage Efficiency of 90%	Aggre-flex Drainage 97.8% Rollershield Drainage 99.2% QRW1 Drainage 97.8%
* Base Coat perm value based on Master Wall F&M ** Finish perm value based on Master Wall Perfect Texture *** AC 235 (ASTM E 2568) – Acceptance Criteria for EIFS Clad Drainage Wall Assemblies			
Tensile Bond	ASTM C297/E2134	Minimum 15 psi (104 kPa) – substrate or insulation failure	Plywood/EPSA 67 psi (464) OSB/ EPSA 22 psi (152) Brick/F&M 105 psi (728) Concrete/F&M 94 psi (651) Gypsum/F&M 30 psi (208)
Tensile Bond	ASTM D897	Bond strength before and after 2000 hours florescent UV condensation weathering.	Before 24.6 psi After 22.7 psi
Transverse Wind Load	ASTM E330	Withstand positive and negative wind loads as specified by the building code	Pass. Assemblies vary from 68-287 psf*
* Ultimate wind loads – contact Master Wall for specific assemblies.			



IMPACT RESISTANCE (ASTM E2486/EIMA 101.86)

Description	OZ/SY	IN-LB Results	Joules	EIMA Classification
Standard Mesh	4.5	50-89	6-10	Medium
Hi-Tech Mesh	6.0	50-89	6-10	Medium
Medium Mesh	10.4	50-89	10-17	Medium
Medium & Standard Mesh	10.4 & 4.5	90-150	10-17	High Impact
Strong & Standard Mesh	15.0 & 4.5	Over 150	>17	Ultra High Impact
Ultra & Standard Mesh	21.0 & 4.5	Over 150	>17	Ultra High Impact

CEMPLASTER FIBERSTUCCO

Test	Test Method	Criteria	Results
Finishes & Coatings	Varies		Reference EIFS & Coatings Data
Freeze-Thaw	ICC AC11	No deleterious effects after 10 cycles	Pass
Transverse Load	ICC AC11/ASTM E330	Withstand positive and negative wind loads as specified by the building code	Pass. Assemblies vary from 81-124 psf*
Compressive Strength	ASTM C109	Average load for cured sample	1910 psi
Fire Resistance	ASTM E119	No effect on the fire resistance of a rated wall assembly	See Technical Bulletin MW#168-030111 for assemblies
Combustibility	ASTM E136	Standard Test Method for Assessing Combustibility of Materials in a Vertical Tube Furnace at 750°C, Option A	Pass
Accelerated Weathering	ASTM G26/G155	No deleterious effects after 2000 hours	Pass

* Ultimate wind loads – contact Master Wall for specific assemblies.



ROLLERSHIELD LAB (LIQUID APPLIED AIR/WATER BARRIER)

Test	Test Method	Criteria	Results
Solids Content	Calculation		Rollershield RS – 69.52% solids by weight (55.05% by volume), Rollershield TG – 73.85% solids by weight (60.12% by volume), Rollershield VB – 68.19% solids by weight (52.97% by volume)
Tensile Bond	ASTM C297/E2134 ICC ES (AC 212)*	Minimum 15 psi (104 kPa)	Dens Glass Gold 31 (215), Exterior Gypsum 28 (194), OSB 40 (277), Plywood 79 (563), Cement Board 70 (485), Copper 185 (1282), Galvanized steel 180 (1248), PVC 168 (1165), Aluminum 184 (1275), Coated Aluminum 203 (1407), Stainless Steel 183 (1269)
Freeze-thaw	ASTM E2485/ICC-ES Proc. ICC ES (AC 212)*	No deleterious effects after 10 cycles	Pass: Plywood, Cement Board, OSB, Exterior Gypsum (ASTM C79/C1396) and Dens Glass Gold (ASTM C1377) substrates
Water Resistance	ASTM D2247 ICC ES (AC 212)*	No deleterious effects after 14 days exposure ¹	Pass: Plywood Cement Board, OSB, Exterior Gypsum (ASTM C79/C1396) and Dens Glass Gold (ASTM C1377) substrates
Water Vapor Transmission	ASTM E96 Proc. B ICC ES (AC 212)*	Vapor Permeable	30 perms (Rollershield RS) ² 12 perms (Rollershield TG) 0.07 perms desiccant (A), 1.35 perms water (B)(Rollershield VB)
Air Permeance	ASTM E2178	No ICC or ANSI/EIMA Criteria ASHRAE/IECC max. 0.004 cfm/ft ² @ 1.57 psf	0.001 cfm/ft ² @ 1.57 psf 0.001 L/s/m ² @ 75 Pa
Air Leakage	ASTM E2357	No ICC or ANSI/EIMA Criteria ASHRAE/IECC max. 0.04 cfm/ft ² @ 1.57 psf	0.0006 cfm/ft ² @ 1.57 psf, 0.003 L/s/m ² @ 75 Pa 0.04 cfm/ft ² @ 6.24 psf, 0.02 L/s/m ² @ 300 Pa
Structural Performance	ASTM E1233 Proc. A ICC ES (AC 212)*	Minimum 10 positive cycles at 1/240 deflection; No cracking in field, at joints or interface with flashing	Pass
Racking	ASTM E72 ICC ES (AC 212)*	No cracking in field, at joints or interface with flashing at net deflection of 3.2 mm (1/8 inch)	Pass
Restrained Environmental	ICC-ES Procedure ICC ES (AC 212)*	5 cycles; No cracking in field, at joints or interface with flashing	Pass
Water Penetration	ASTM E331 ICC ES (AC 212)*	No water penetration beyond the inner-most plane of the wall after 15 minutes at 137 Pa (2.86 psf)	Pass
UV Exposure	ICC ES Proc. ICC ES (AC 212)*	210 hours of exposure, rated for 6 months of exposure	Pass
Accelerated Aging	ICC ES Proc. ICC ES (AC 212)*	25 cycles of wetting and drying	Pass
Hydrostatic Pressure Test	AATCC 127 ICC ES (AC 212)*	ICC: 549 mm (21.6 in) water column for 5 hours	Pass
Surface Burning Characteristics	ASTM E84	Flame Spread < 25 Smoke Developed < 450	Pass
Intermediate Multi-Story Fire Test	NFPA 285 (UBC 26-9)	No flame spread with up to 4" insulation	Pass
Nail Sealability	ASTM D1970	Standard Specification for Self-Adhering Polymer Modified Bituminous Sheet Materials Used as Steep Roofing Underlayment for Ice Dam Protection	Pass (22 mils)
Heat and Smoke Release Rates	ASTM E1354, IBC Section 1403.5, Exception 2 Requirements	Peak Heat Release Rate <150 kW/m ² , Total Heat Release Rate <20 MJ/m ² , Effective Heat of Combustion <18 MJ/kg	RS: Peak Heat Release Rate = 32 kW/m ² , Total Heat Release Rate = 3.6 MJ/m ² , Effective Heat of Combustion = 2.5 MJ/kg, VB: Peak Heat Release Rate = 336 kW/m ² , Total Heat Release Rate = 8.8 MJ/m ² , Effective Heat of Combustion = 9.3 MJ/kg

* (AC212 – Acceptance Criteria for Water-Resistive Coatings Used as Water-Resistive Barriers over Exterior Sheathing, also referred to as ASTM E 2570

1. No cracking, checking, rusting, crazing, erosion, blistering, peeling, or delamination when viewed under 5x magnification

2. Defined as a Class III vapor retarder per the 2015 IBC and IRC





Rollershield Drainage CIFS® – Continuously Insulated Section 07 24 19



Master Wall Inc.®

PO Box 397
Fortson, GA 31808
706-569-0092
800-755-0825
www.masterwall.com

Master Wall Guide Specification RDCIFS12 Rollershield Drainage CIFS® 12 Assembly

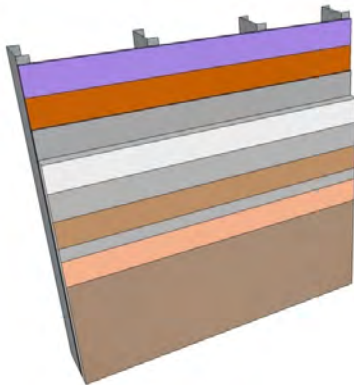

Rollershield Drainage CIFS® 12

- Rollershield Air/Water Barrier
- Master Wall Adhesive
- Master Wall Insulation Board
- Standard Mesh minimum
- Master Wall Base Coat
- Primecoat Primer
- Superior Finish

Rollershield Drainage CIFS® 12 12-year Limited Warranty

1.0 General

This is a short form specification. Refer to Rollershield Drainage CIFS® specifications and details for additional information.

1.1 System Description

The Master Wall® Rollershield Drainage Continuously Insulated Finish System (CIFS®) is a Class PB (Polymer Based) EIF System consisting of a roll-applied water barrier, vertical channel adhesive attachment, insulation board, reinforcing mesh and a textured finish.

1.2 Design Requirements:

- Reference Master Wall® suggested details and architectural drawings for specific detail requirements.
- Slope all surfaces a minimum of 1:2 (6" in 12") to shed water, maximum 12" (305mm) wide.
- Maximum deflection of substrates shall not exceed L/240.
- Typical acceptable substrates include unpainted brick, masonry, concrete, Portland cement plaster (stucco), exterior grade gypsum sheathing (ASTM C1396), Glass Fiber Sheathing (ASTM C1177), CDX exterior grade plywood, Exposure 1 Oriented Strand Board (OSB).
- Expansion joints are required in the cladding at building expansion joints, panel joints, floor lines in wood framed construction, and other areas where significant movement occurs.

1.3 Quality Assurance

- The Rollershield Drainage System shall be recognized by local building codes.
- The system shall meet or exceed ASTM C1397 and detailed in accordance with ASTM E2511.
- The system shall have been tested for fire performance in accordance with ASTM E108, ASTM E-84, NFPA 265, and NFPA 268.
- The system shall have been tested for drainage performance in accordance with ASTM E331.

Master Wall Guide Specification RDCIFS12

Issued: 9/1/20

Page 1 of 2



Rollershield Drainage CIFS® – Continuously Insulated Section 07 24 19

1.4 Job Conditions

- A. Store all materials protected from weather and direct sunlight at temperatures above 40oF (5oC).
- B. The ambient and wall temperature shall be a minimum of 40oF (5oC) and shall remain so for at least 24 hours after installation.

1.5 Warranty

- A. Master Wall Rollershield Drainage CIFS® 12-year limited warranty.

2.0 Products

All components of the Rollershield Drainage System shall be manufactured by Master Wall® and supplied by an authorized distributor.

A. SuperiorShield Water Barrier & Flashing Tapes:

SuperiorShield Rollershield (RS): A 100% pure acrylic-based roll-applied weather-resistive barrier.

SuperiorShield Trowel Grade (TG): A 100% pure acrylic-based trowel grade water-resistive barrier.

SuperiorShield Flashing Tape: A lightweight nonwoven joint treatment material.

B. Master Wall Adhesives:

1. Foam & Mesh Adhesive (F&M), F&M Plus: A 100% pure acrylic-based adhesive that is field mixed with Portland cement.

2. Master Wall® Bagged Base (MBB), MBB Plus: A ready to use dry base that is field mixed with water.

C. Insulation Boards: Master Wall® Insulation Board.

D. Aggre-flex Mesh: Available in Standard, Detail, Hi-Tech, Medium, Strong and Ultra. Minimum Standard Mesh required.

E. Master Wall Base Coats:

1. Foam & Mesh Adhesive (F&M), F&M Plus.

2. Master Wall® Bagged Base (MBB), MBB Plus.

F. Primecoat: 100% pure acrylic primer.

G. Superior Finish: 100% pure acrylic formulation with integral color and texture. Perfect Swirl 2.0, Fine Sand 1.0, Medium Sand 1.5, Versatex 0.5 textures.

3.0 Installation

A. Inspect the substrate to ensure that it is free of all foreign materials that would affect the adhesion of the Rollershield Drainage CIFS® System.

B. Apply the system in strict accordance with Master Wall® specifications, product data sheets, architectural drawings and architectural specifications using the products noted above.

Disclaimer

This Specification is published for general informational purposes only and is not intended to imply that these are the only materials, procedures, or methods, which are available or suitable. Materials, procedures, or methods may vary according to the particular circumstances, local building code requirements, design conditions, or statutory and regulatory requirements. While the information in this specification is believed to be accurate and reliable, it is presented without guarantee or responsibility on the part of Master Wall Inc.®



Master Wall Inc.®
Building a Culture of Excellence

**ROLLERSHIELD
DRAINAGE CIFS®**

SYSTEM DETAIL

ROLLERSHIELD DRAINAGE CIFS® TYPICAL DETAILS

*RDCIFS-01 STANDARD AND IMPACT CROSS SECTION
RDCIFS-02 TYPICAL/OPTIONAL INSULATION
RDCIFS-03 TYPICAL SUPERIORSHIELD APPLICATION
RDCIFS-04 TYPICAL INSULATION BOARD LAYOUT
RDCIFS-05 STUCCO WEEP SCREED TERMINATION
RDCIFS-06 FLASHING ANGLE TERMINATION
RDCIFS-07 DRAINAGE TRACK TERMINATION
RDCIFS-08 DV ROLL TERMINATION
RDCIFS-09 TERMINATION AT PAVEMENT
RDCIFS-10 TERMINATION AT SUPPORTED SLAB
RDCIFS-11 TYPICAL STOREFRONT WINDOW HEAD
RDCIFS-12 TYPICAL STOREFRONT WINDOW JAMB
RDCIFS-13 TYPICAL STOREFRONT WINDOW SILL
RDCIFS-14 TYPICAL FLANGED WINDOW HEAD
RDCIFS-15 FLANGED WINDOW JAMB
RDCIFS-16 TYPICAL FLANGED WINDOW SILL
RDCIFS-17 TYPICAL HOLLOW METAL DOOR HEAD
RDCIFS-18 TYPICAL HOLLOW METAL DOOR JAMB
RDCIFS-19 DECK FLASHING TERMINATION
RDCIFS-20 TYPICAL PLUMBING SPIGOT DETAIL
RDCIFS-21 TYPICAL PIPE PENETRATION DETAIL
RDCIFS-22 TYPICAL DRYER VENT DETAIL
RDCIFS-23 TYPICAL DOWNSPOUT ATTACHMENT
RDCIFS-24 TYPICAL SIGNAGE ATTACHMENT
RDCIFS-25 TYPICAL FIXTURE ATTACHMENT
RDCIFS-26 TYPICAL AESTHETIC JOINTS
RDCIFS-27 TYPICAL AESTHETIC PROJECTION
RDCIFS-28 VERTICAL EXPANSION JOINT
RDCIFS-29 HORIZONTAL EXPANSION JOINT - WOOD FRAME
RDCIFS-30 HORIZONTAL EXPANSION JOINT - METAL FRAME
RDCIFS-31 FLOOR LINE DRAINAGE
RDCIFS-32 DISSIMILAR SUBSTRATES
RDCIFS-33 DISSIMILAR MATERIALS
RDCIFS-34 DISSIMILAR CLADDING TRANSITION CONTINUOUS WATER BARRIER
RDCIFS-35 DISSIMILAR CLADDING TRANSITION WITH FLASHING
RDCIFS-36 SOFFIT/DRIP
RDCIFS-37 PARAPET CAP
RDCIFS-38 FLAT ROOF TERMINATION
RDCIFS-39 SLOPED ROOF TERMINATION
RDCIFS-40 KICK OUT FLASHING
RDCIFS-41 CHIMNEY CRICKET*



PO Box 397 · Fortson · GA · 31808 · 800-755-0825 · masterwall.com

These drawings relay the conceptual conditions of Master Wall® Systems and are not the construction drawings. Ultimately the design and detailing of an entire wall system is the responsibility of a professional. These details will guide the design professional in the use of Master Wall® Products. Master Wall disclaims design, warranty or construction intent or responsibility. Bold or Brand Name = Master Wall® Product. ©2024 Master Wall Inc.®



Master Wall Inc.
Building a Culture of Excellence

**ROLLERSHIELD
DRAINAGE CIFS®**

SYSTEM DETAIL

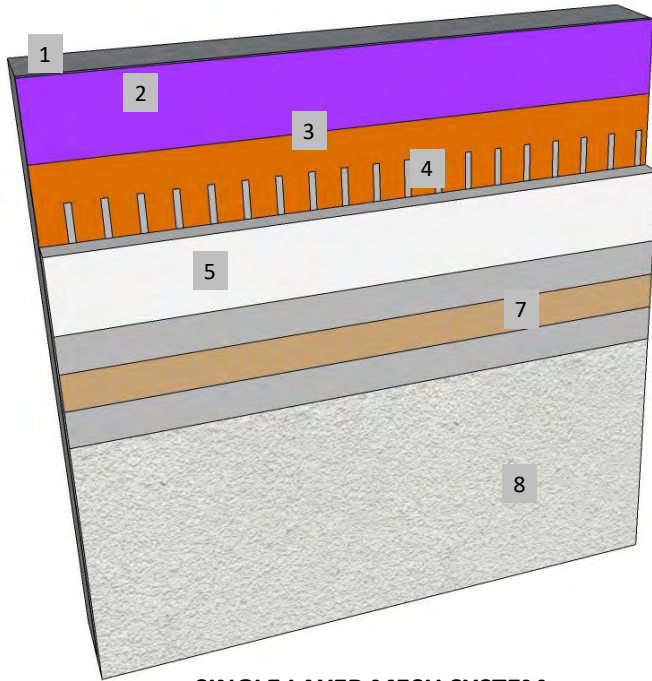

SINGLE LAYER MESH SYSTEM

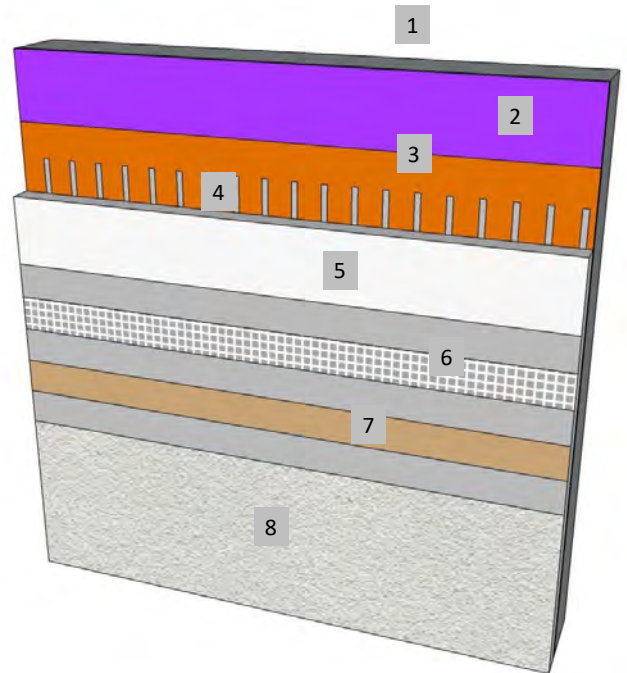

DOUBLE LAYER MESH SYSTEM

1. FRAMING
2. APPROVED SUBSTRATE
3. ROLLERSHIELD AIR/WATER BARRIER
4. CHANNELED ADHESIVE
5. MASTER WALL INSULATION BOARD
6. MASTER WALL BASE COAT AND STRONG OR ULTRA MESH
7. MASTER WALL BASE COAT AND MESH
8. SUPERIOR FINISH

RDCIFS-01 STANDARD AND IMPACT CROSS SECTION



Master Wall Inc.
Building a Culture of Excellence

PO Box 397 · Fortson · GA · 31808 · 800-755-0825 · masterwall.com

These drawings relay the conceptual conditions of Master Wall® Systems and are not the construction drawings. Ultimately the design and detailing of an entire wall system is the responsibility of a professional. These details will guide the design professional in the use of Master Wall® Products. Master Wall disclaims design, warranty or construction intent or responsibility. Bold or Brand Name = Master Wall® Product. ©2024 Master Wall Inc.®



Master Wall Inc.
Building a Culture of Excellence

**ROLLERSHIELD
DRAINAGE CIFS®**

SYSTEM DETAIL

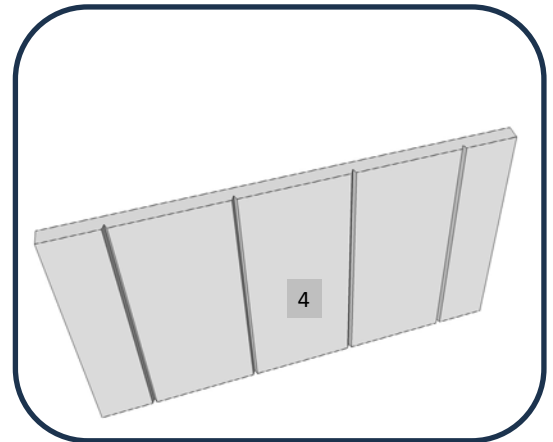
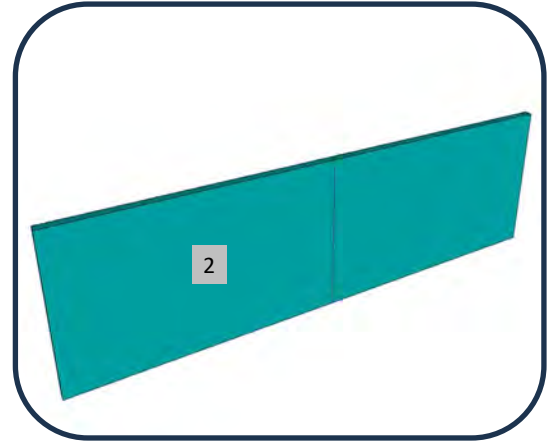
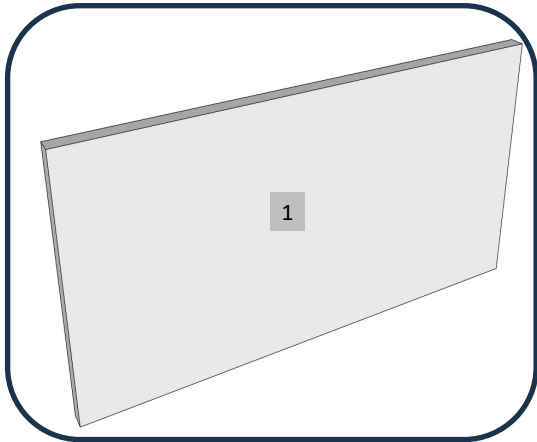

1. MASTER WALL® INSULATION BOARD – STANDARD ASTM C578 TYPE 1
2. DOW® STYROFOAM™ PANEL CORE 20 OR OWENS CORNING® FOAMULAR® 250 (PLANED) – OPTIONAL ASTM C578, TYPE X
3. NEOPOR® GPS INSULATION BOARD - OPTIONAL ASTM C578, TYPE I, WITH ADDITIONAL SUPPORT OF FOUR WIND-DEVIL 2 PLATE OR APPROVED EQUAL WITH THE APPROPRIATE CORROSION-RESISTANT FASTENER TO MEET NEOPOR® REQUIREMENTS. TWO COATS OF ROLLERSHIELD IS REQUIRED.
4. GROOVED INSULATION BOARD OPTION

RDCIFS-02 TYPICAL/OPTIONAL INSULATION

M Master Wall Inc.
Building a Culture of Excellence

PO Box 397 · Fortson · GA · 31808 · 800-755-0825 · masterwall.com

These drawings relay the conceptual conditions of Master Wall® Systems and are not the construction drawings. Ultimately the design and detailing of an entire wall system is the responsibility of a professional. These details will guide the design professional in the use of Master Wall® Products. Master Wall disclaims design, warranty or construction intent or responsibility. Bold or Brand Name = Master Wall® Product. ©2024 Master Wall Inc.®



Master Wall Inc.
Building a Culture of Excellence

**ROLLERSHIELD
DRAINAGE CIFS®**

SYSTEM DETAIL

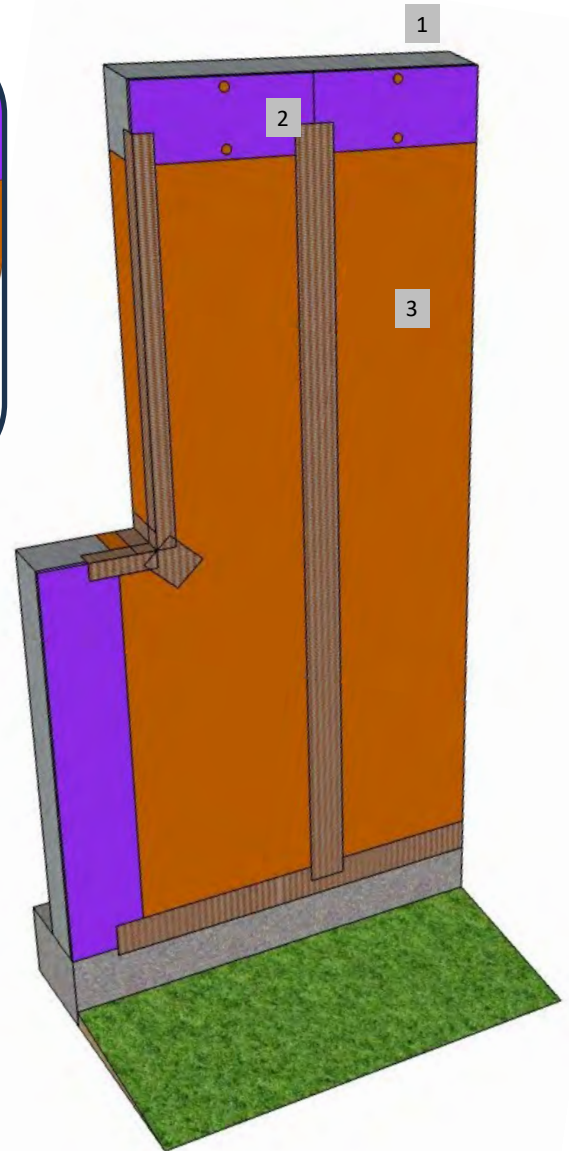
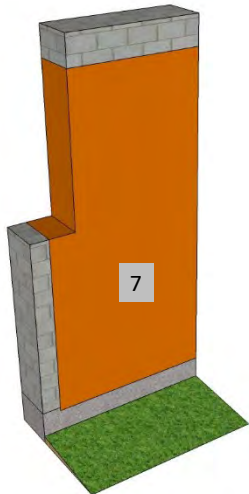
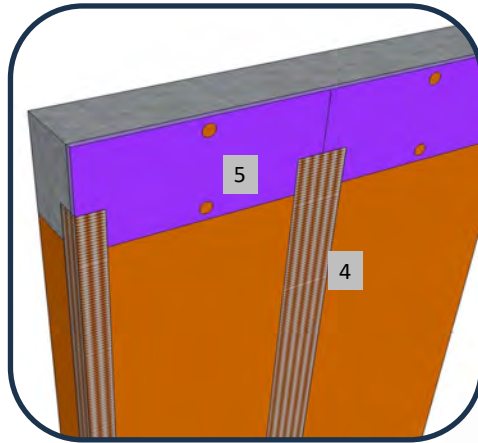
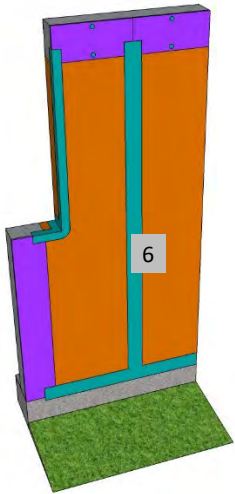

1. FRAMING
2. APPROVED SUBSTRATE
3. ROLLERSHIELD AIR/WATER BARRIER
4. SUPERIORSHIELD FLASHING TAPE REINFORCEMENT AT SUBSTRATE JOINTS AND TRANSITIONS
5. SPOT FASTENERS WHERE NEEDED
6. SUPERIORFLASH OPTION AT SEAMS AND OPENINGS
7. CMU/CONCRETE APPLICATION

RDCIFS-03 TYPICAL SUPERIORSHIELD APPLICATION

M Master Wall Inc.
Building a Culture of Excellence

PO Box 397 · Fortson · GA · 31808 · 800-755-0825 · masterwall.com

These drawings relay the conceptual conditions of Master Wall® Systems and are not the construction drawings. Ultimately the design and detailing of an entire wall system is the responsibility of a professional. These details will guide the design professional in the use of Master Wall® Products. Master Wall disclaims design, warranty or construction intent or responsibility. Bold or Brand Name = Master Wall® Product. ©2024 Master Wall Inc.®



Master Wall Inc.
Building a Culture of Excellence

**ROLLERSHIELD
DRAINAGE CIFS®**

SYSTEM DETAIL



1. FRAMING
2. APPROVED SUBSTRATE
3. ROLLERSHIELD AIR/WATER BARRIER
4. MASTER WALL INSULATION BOARD ADHERED WITH CHanneled ADHESIVE
5. INSTALL INSULATION IN A RUNNING BOND PATTERN
6. INTERLOCK INSIDE AND OUTSIDE CORNERS
7. CUT INSULATION BOARD AROUND OPENINGS, DO NOT ALIGN WITH JAMBS OR SILLS
8. BACKWRAP MESH AT OPENINGS SHOWN ' BACKWRAP OR PREWRAP 2-1/2" (63.5 MM) BEHIND INSULATION BOARD
9. 9" X 12" (23 CM X 30 CM) DIAGONAL REINFORCEMENT AT ALL INSIDE CORNERS

RDCIFS-04 TYPICAL INSULATION BOARD LAYOUT

M Master Wall Inc.
Building a Culture of Excellence

These drawings relay the conceptual conditions of Master Wall® Systems and are not the construction drawings. Ultimately the design and detailing of an entire wall system is the responsibility of a professional. These details will guide the design professional in the use of Master Wall® Products. Master Wall disclaims design, warranty or construction intent or responsibility. Bold or Brand Name = Master Wall® Product. ©2024 Master Wall Inc.®



Master Wall Inc.
Building a Culture of Excellence

**ROLLERSHIELD
DRAINAGE CIFS®**

SYSTEM DETAIL



1. FRAMING
2. APPROVED SUBSTRATE
3. ROLLERSHIELD AIR/WATER BARRIER
4. AIR SEAL OVER FOUNDATION 1" (25 MM) MIN. WITH SUPERIORSHIELD FLASHING TAPE OR SUPERIORFLASH
5. STUCCO WEEP SCREED ACCESSORY, 1/2" (12.7 MM) GROUND RECOMMENDED PLACED 1" (25 MM) MIN. OVER FOUNDATION
6. FLASH ONTO WEEP SCREED WITH SUPERIORSHIELD FLASHING TAPE OR SUPERIORFLASH
7. BACKWRAP OR PREWRAP 2-1/2" (63.5 MM) BEHIND CIFS®
8. MASTER WALL INSULATION BOARD ADHERED WITH CHanneled ADHESIVE
9. MASTER WALL BASE COAT AND MESH
10. SUPERIOR FINISH
11. KEEP CIFS® 6" (152 MM) MIN. ABOVE GRADE

RDCIFS-05 STUCCO WEEP SCREED TERMINATION

M Master Wall Inc.
Building a Culture of Excellence

PO Box 397 · Fortson · GA · 31808 · 800-755-0825 · masterwall.com

These drawings relay the conceptual conditions of Master Wall® Systems and are not the construction drawings. Ultimately the design and detailing of an entire wall system is the responsibility of a professional. These details will guide the design professional in the use of Master Wall® Products. Master Wall disclaims design, warranty or construction intent or responsibility. Bold or Brand Name = Master Wall® Product. ©2024 Master Wall Inc.®



Master Wall Inc.
Building a Culture of Excellence

**ROLLERSHIELD
DRAINAGE CIFS®**

SYSTEM DETAIL



1. FRAMING
2. APPROVED SUBSTRATE
3. ROLLERSHIELD AIR/WATER BARRIER
4. AIR SEAL OVER FOUNDATION 1" (25 MM) MIN. WITH SUPERIORSHIELD FLASHING TAPE OR SUPERIORFLASH
5. FLASHING ACCESSORY PLACED 1" (25 MM) MIN. OVER FOUNDATION
6. FLASH WITH SUPERIORSHIELD FLASHING TAPE OR SUPERIORFLASH
7. BACKWRAP OR PREWRAP 2-1/2" (63.5 MM) BEHIND CIFS®
8. MASTER WALL INSULATION BOARD ADHERED WITH CHANNELED ADHESIVE
9. MASTER WALL BASE COAT AND MESH
10. SUPERIOR FINISH
11. KEEP CIFS® 6" (152 MM) MIN. ABOVE GRADE

RDCIFS-06 FLASHING ANGLE TERMINATION

M Master Wall Inc.
Building a Culture of Excellence

PO Box 397 · Fortson · GA · 31808 · 800-755-0825 · masterwall.com

These drawings relay the conceptual conditions of Master Wall® Systems and are not the construction drawings. Ultimately the design and detailing of an entire wall system is the responsibility of a professional. These details will guide the design professional in the use of Master Wall® Products. Master Wall disclaims design, warranty or construction intent or responsibility. Bold or Brand Name = Master Wall® Product. ©2024 Master Wall Inc.®



Master Wall Inc.
Building a Culture of Excellence

**ROLLERSHIELD
DRAINAGE CIFS®**

SYSTEM DETAIL

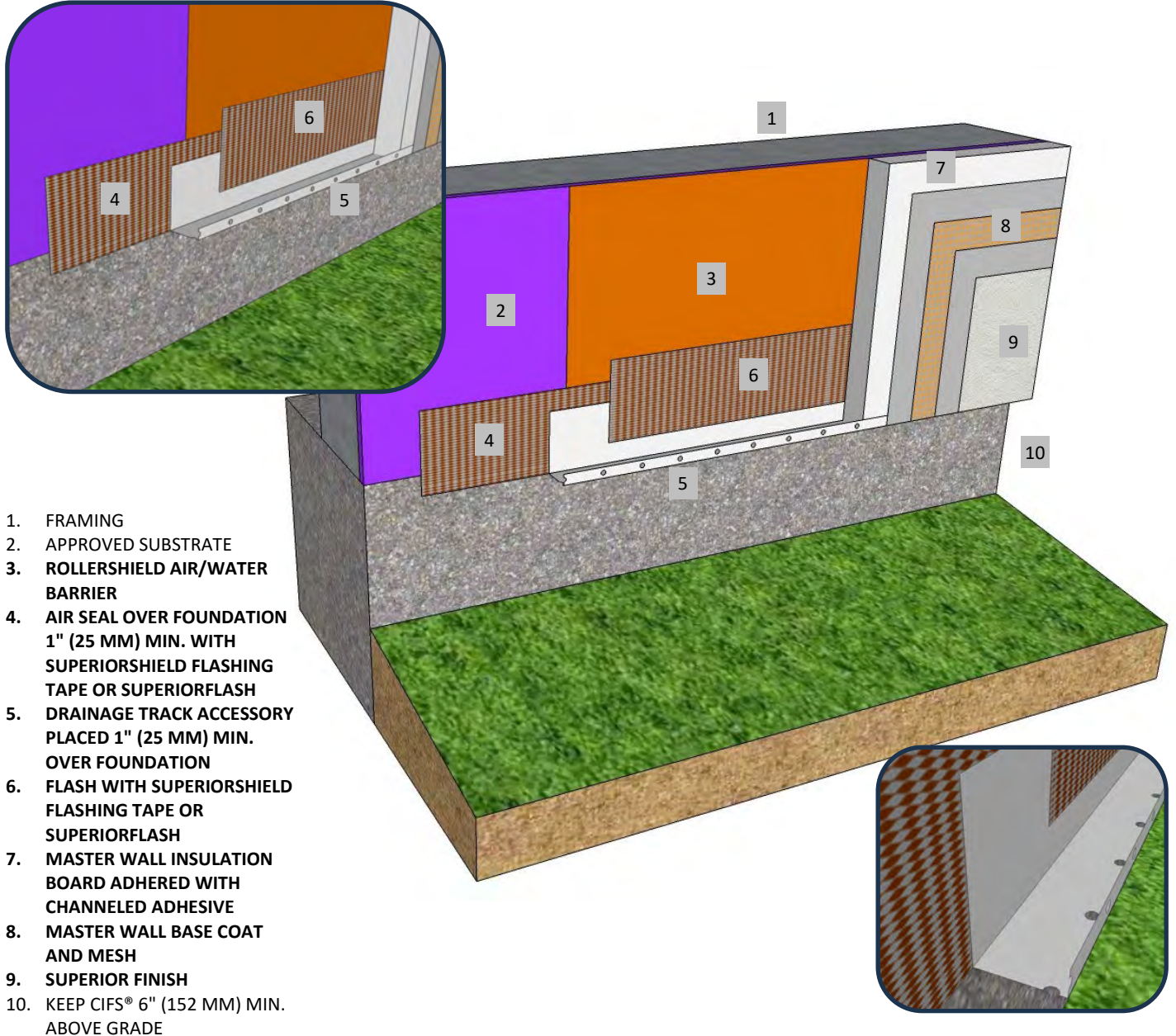

1. FRAMING
2. APPROVED SUBSTRATE
3. ROLLERSHIELD AIR/WATER BARRIER
4. AIR SEAL OVER FOUNDATION 1" (25 MM) MIN. WITH SUPERIORSHIELD FLASHING TAPE OR SUPERIORFLASH
5. DRAINAGE TRACK ACCESSORY PLACED 1" (25 MM) MIN. OVER FOUNDATION
6. FLASH WITH SUPERIORSHIELD FLASHING TAPE OR SUPERIORFLASH
7. MASTER WALL INSULATION BOARD ADHERED WITH CHanneled ADHESIVE
8. MASTER WALL BASE COAT AND MESH
9. SUPERIOR FINISH
10. KEEP CIFS® 6" (152 MM) MIN. ABOVE GRADE

RDCIFS-07 DRAINAGE TRACK TERMINATION

M Master Wall Inc.
Building a Culture of Excellence

PO Box 397 · Fortson · GA · 31808 · 800-755-0825 · masterwall.com

These drawings relay the conceptual conditions of Master Wall® Systems and are not the construction drawings. Ultimately the design and detailing of an entire wall system is the responsibility of a professional. These details will guide the design professional in the use of Master Wall® Products. Master Wall disclaims design, warranty or construction intent or responsibility. Bold or Brand Name = Master Wall® Product. ©2024 Master Wall Inc.®



Master Wall Inc.
Building a Culture of Excellence

**ROLLERSHIELD
DRAINAGE CIFS®**

SYSTEM DETAIL

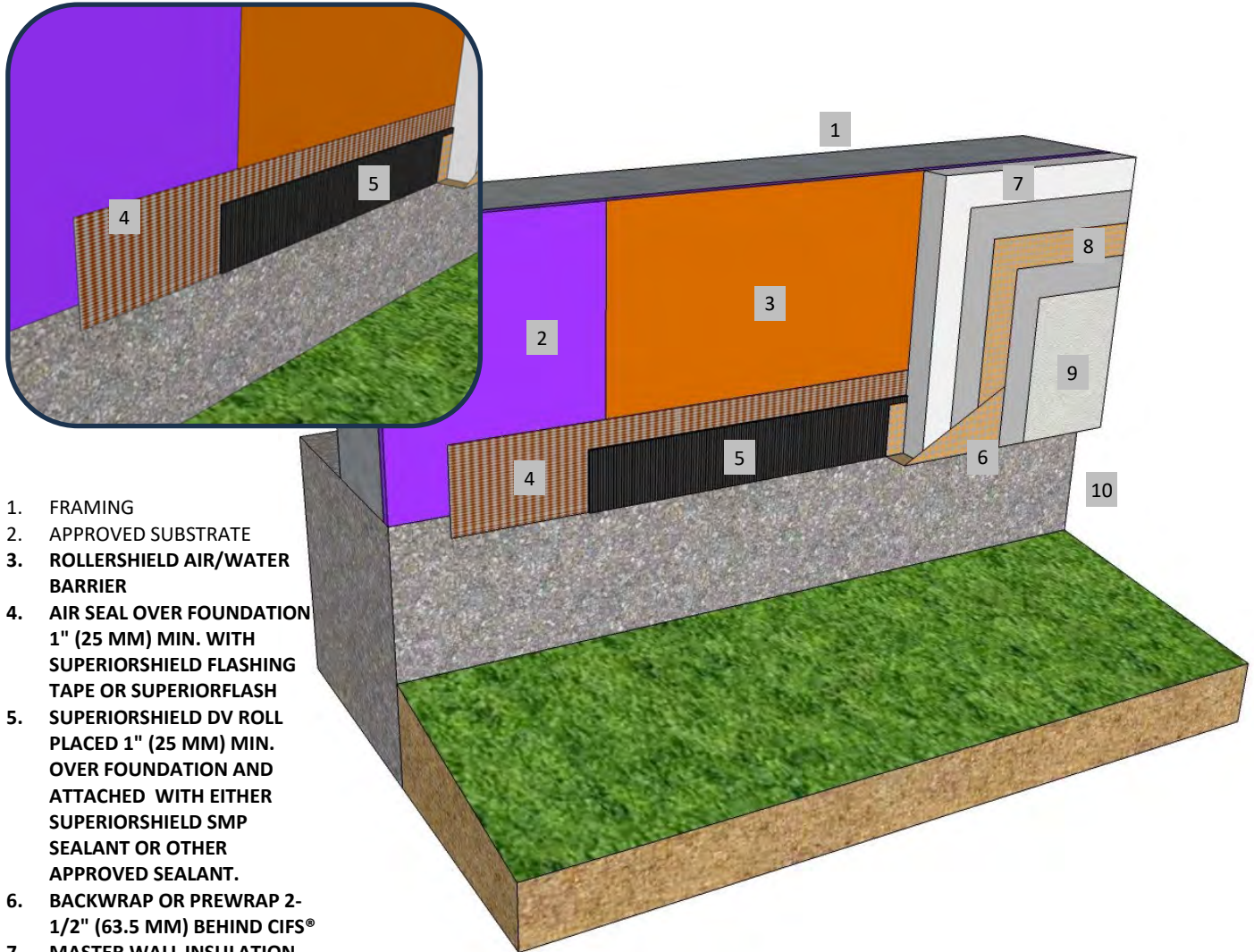

1. FRAMING
2. APPROVED SUBSTRATE
3. ROLLERSHIELD AIR/WATER BARRIER
4. AIR SEAL OVER FOUNDATION 1" (25 MM) MIN. WITH SUPERIORSHIELD FLASHING TAPE OR SUPERIORFLASH
5. SUPERIORSHIELD DV ROLL PLACED 1" (25 MM) MIN. OVER FOUNDATION AND ATTACHED WITH EITHER SUPERIORSHIELD SMP SEALANT OR OTHER APPROVED SEALANT.
6. BACKWRAP OR PREWRAP 2-1/2" (63.5 MM) BEHIND CIFS®
7. MASTER WALL INSULATION BOARD ADHERED WITH CHANNELED ADHESIVE
8. MASTER WALL BASE COAT AND MESH
9. SUPERIOR FINISH
10. KEEP CIFS® 6" (152 MM) MIN.

RDCIFS-08 SUPERIORSHIELD DV ROLL TERMINATION

M Master Wall Inc.
Building a Culture of Excellence

PO Box 397 · Fortson · GA · 31808 · 800-755-0825 · masterwall.com

These drawings relay the conceptual conditions of Master Wall® Systems and are not the construction drawings. Ultimately the design and detailing of an entire wall system is the responsibility of a professional. These details will guide the design professional in the use of Master Wall® Products. Master Wall disclaims design, warranty or construction intent or responsibility. Bold or Brand Name = Master Wall® Product. ©2024 Master Wall Inc.®



Master Wall Inc.
Building a Culture of Excellence

**ROLLERSHIELD
DRAINAGE CIFS®**

SYSTEM DETAIL

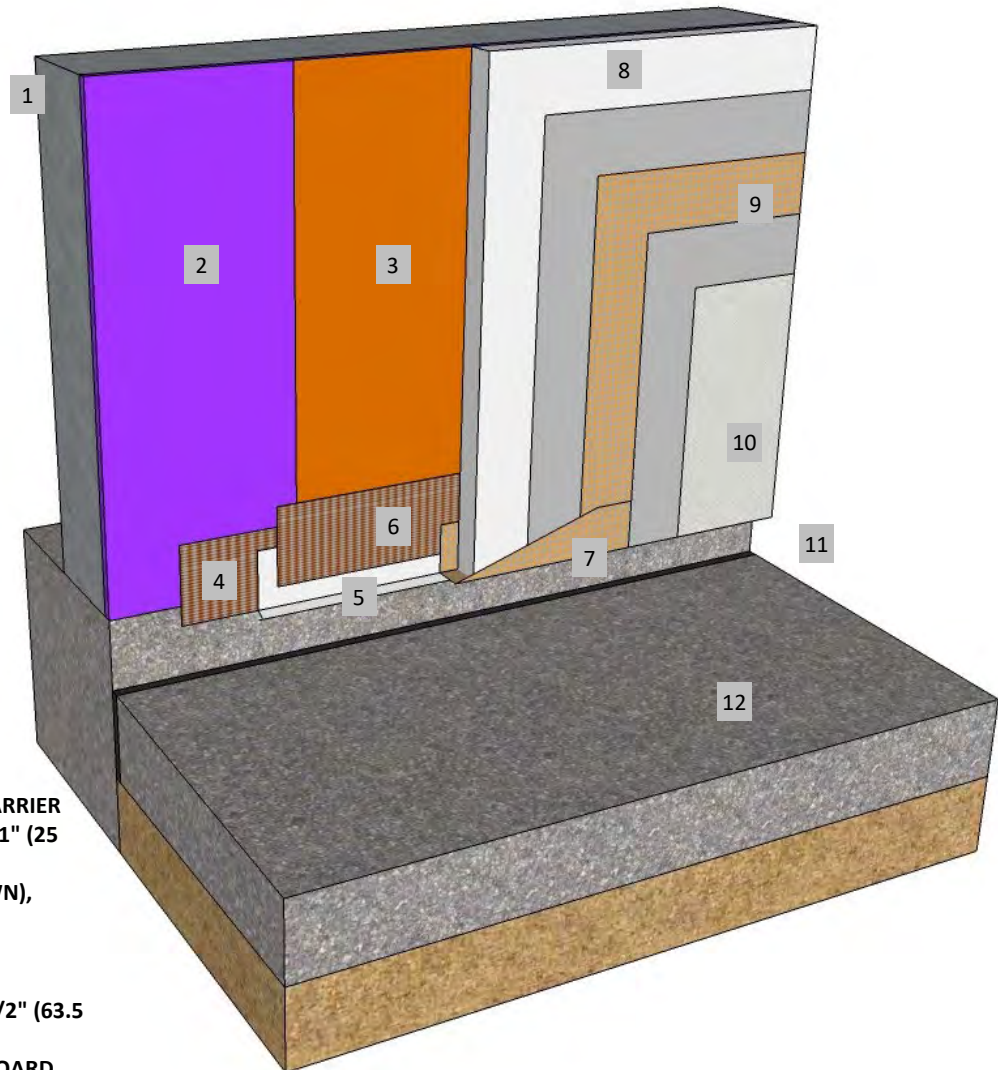

1. FRAMING
2. APPROVED SUBSTRATE
3. ROLLERSHIELD AIR/WATER BARRIER
4. AIR SEAL OVER FOUNDATION 1" (25 MM) MIN.
5. STUCCO WEEP SCREED (SHOWN), OTHER TERMINATIONS ALSO ACCEPTABLE
6. FLASH ONTO WEEP SCREED
7. BACKWRAP OR PREWRAP 2-1/2" (63.5 MM) BEHIND CIFS®
8. MASTER WALL INSULATION BOARD ADHERED WITH CHANNELED ADHESIVE
9. MASTER WALL BASE COAT AND MESH
10. SUPERIOR FINISH
11. KEEP CIFS™ 2" (50 MM) MIN. ABOVE PAVEMENT

RDCIFS-09 TERMINATION AT PAVEMENT

M Master Wall Inc.
Building a Culture of Excellence

PO Box 397 · Fortson · GA · 31808 · 800-755-0825 · masterwall.com

These drawings relay the conceptual conditions of Master Wall® Systems and are not the construction drawings. Ultimately the design and detailing of an entire wall system is the responsibility of a professional. These details will guide the design professional in the use of Master Wall® Products. Master Wall disclaims design, warranty or construction intent or responsibility. Bold or Brand Name = Master Wall® Product. ©2024 Master Wall Inc.®



Master Wall Inc.
Building a Culture of Excellence

**ROLLERSHIELD
DRAINAGE CIFS®**

SYSTEM DETAIL

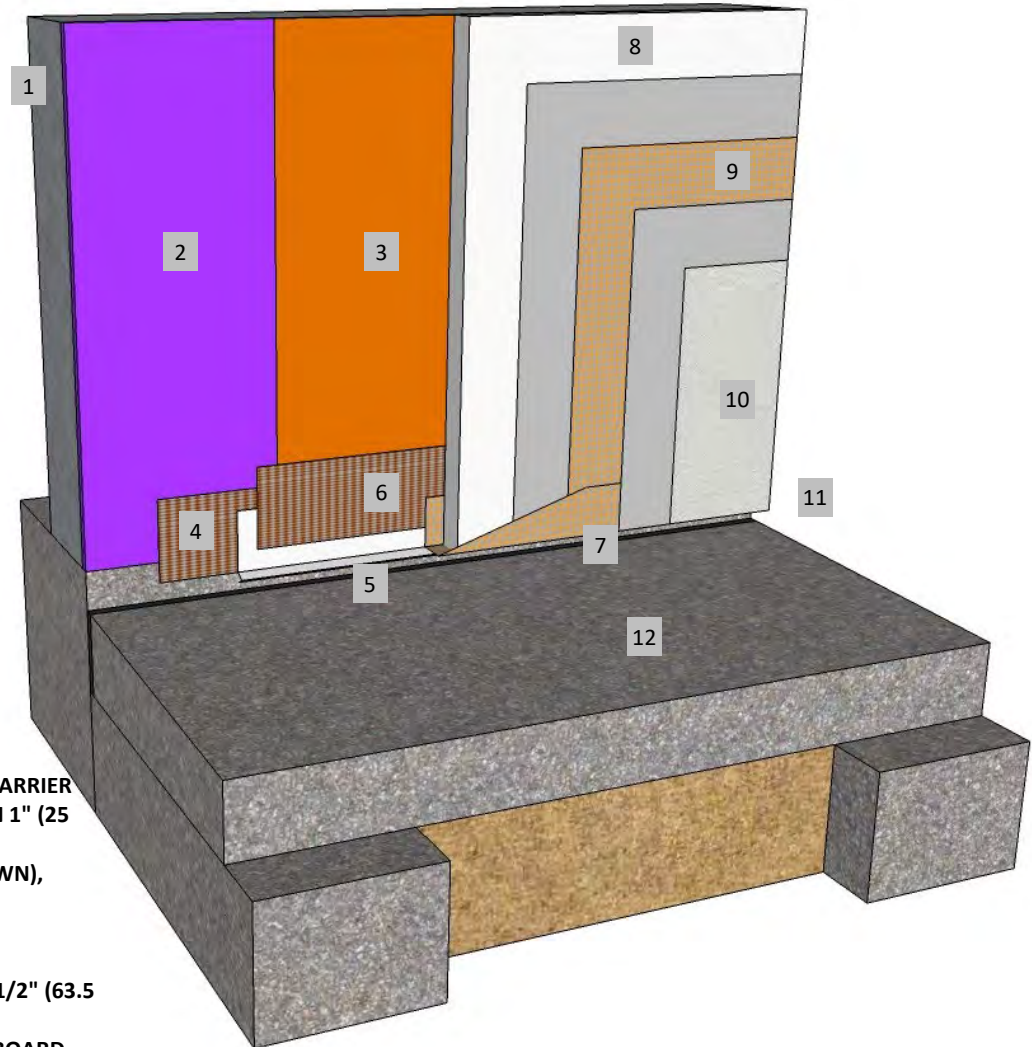

1. FRAMING
2. APPROVED SUBSTRATE
3. ROLLERSHIELD AIR/WATER BARRIER
4. AIR SEAL OVER FOUNDATION 1" (25 MM) MIN.
5. STUCCO WEEP SCREED (SHOWN), OTHER TERMINATIONS ALSO ACCEPTABLE
6. FLASH ONTO WEEP SCREED
7. BACKWRAP OR PREWRAP 2-1/2" (63.5 MM) BEHIND CIFS®
8. MASTER WALL INSULATION BOARD ADHERED WITH CHANNELED ADHESIVE
9. MASTER WALL BASE COAT AND MESH
10. SUPERIOR FINISH
11. KEEP CIFS™ 3/4" (19 MM) MIN. ABOVE SUPPORTED SLAB

RDCIFS-10 TERMINATION AT SUPPORTED SLAB

M Master Wall Inc.
Building a Culture of Excellence

PO Box 397 · Fortson · GA · 31808 · 800-755-0825 · masterwall.com

These drawings relay the conceptual conditions of Master Wall® Systems and are not the construction drawings. Ultimately the design and detailing of an entire wall system is the responsibility of a professional. These details will guide the design professional in the use of Master Wall® Products. Master Wall disclaims design, warranty or construction intent or responsibility. Bold or Brand Name = Master Wall® Product. ©2024 Master Wall Inc.®



Master Wall Inc.
Building a Culture of Excellence

**ROLLERSHIELD
DRAINAGE CIFS®**

SYSTEM DETAIL

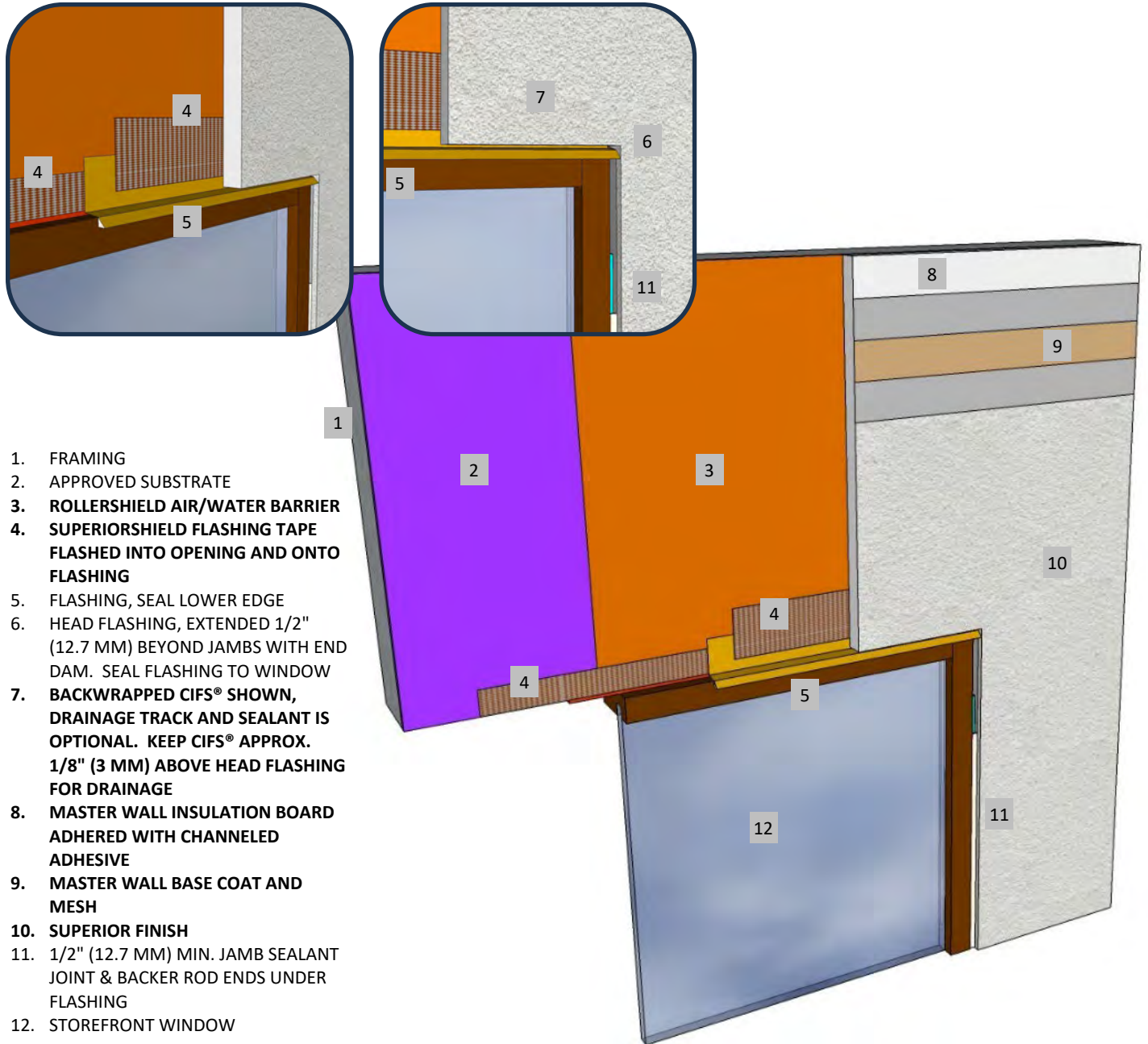

1. FRAMING
2. APPROVED SUBSTRATE
3. **ROLLERSHIELD AIR/WATER BARRIER**
4. **SUPERIORSHIELD FLASHING TAPE FLASHED INTO OPENING AND ONTO FLASHING**
5. FLASHING, SEAL LOWER EDGE
6. HEAD FLASHING, EXTENDED 1/2" (12.7 MM) BEYOND JAMBS WITH END DAM. SEAL FLASHING TO WINDOW
7. **BACKWRAPPED CIFS® SHOWN, DRAINAGE TRACK AND SEALANT IS OPTIONAL. KEEP CIFS® APPROX. 1/8" (3 MM) ABOVE HEAD FLASHING FOR DRAINAGE**
8. **MASTER WALL INSULATION BOARD ADHERED WITH CHanneled ADHESIVE**
9. **MASTER WALL BASE COAT AND MESH**
10. **SUPERIOR FINISH**
11. 1/2" (12.7 MM) MIN. JAMB SEALANT JOINT & BACKER ROD ENDS UNDER FLASHING
12. STOREFRONT WINDOW

RDCIFS-11 TYPICAL STOREFRONT WINDOW HEAD





Master Wall Inc.
Building a Culture of Excellence

**ROLLERSHIELD
DRAINAGE CIFS®**

SYSTEM DETAIL

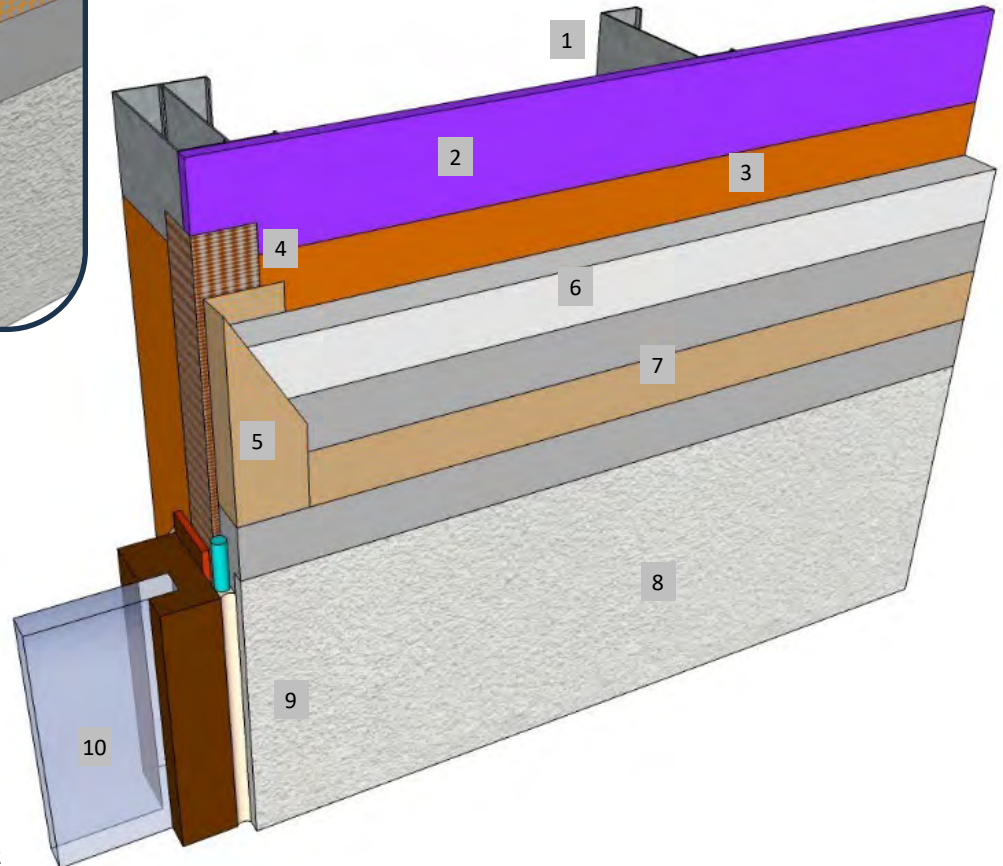
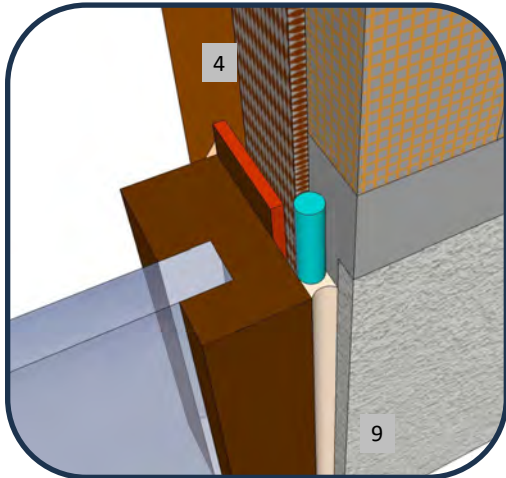

1. FRAMING
2. APPROVED SUBSTRATE
3. ROLLERSHIELD AIR/WATER BARRIER
4. SUPERIORSHIELD FLASHING TAPE WRAPPED INTO OPENING
5. BACKWRAPPED CIFS® SHOWN, EIFS PLASTIC ACCESSORIES ARE OPTIONAL.
6. MASTER WALL INSULATION BOARD ADHERED WITH CHANNELED ADHESIVE
7. MASTER WALL BASE COAT AND MESH
8. SUPERIOR FINISH
9. 1/2" (12.7 MM) MIN. JAMB SEALANT JOINT & BACKER ROD ENDS UNDER FLASHING
10. STOREFRONT WINDOW

RDCIFS-12 TYPICAL STOREFRONT WINDOW JAMB



PO Box 397 · Fortson · GA · 31808 · 800-755-0825 · masterwall.com

These drawings relay the conceptual conditions of Master Wall® Systems and are not the construction drawings. Ultimately the design and detailing of an entire wall system is the responsibility of a professional. These details will guide the design professional in the use of Master Wall® Products. Master Wall disclaims design, warranty or construction intent or responsibility. Bold or Brand Name = Master Wall® Product. ©2024 Master Wall Inc.®



Master Wall Inc.
Building a Culture of Excellence

**ROLLERSHIELD
DRAINAGE CIFS®**

SYSTEM DETAIL

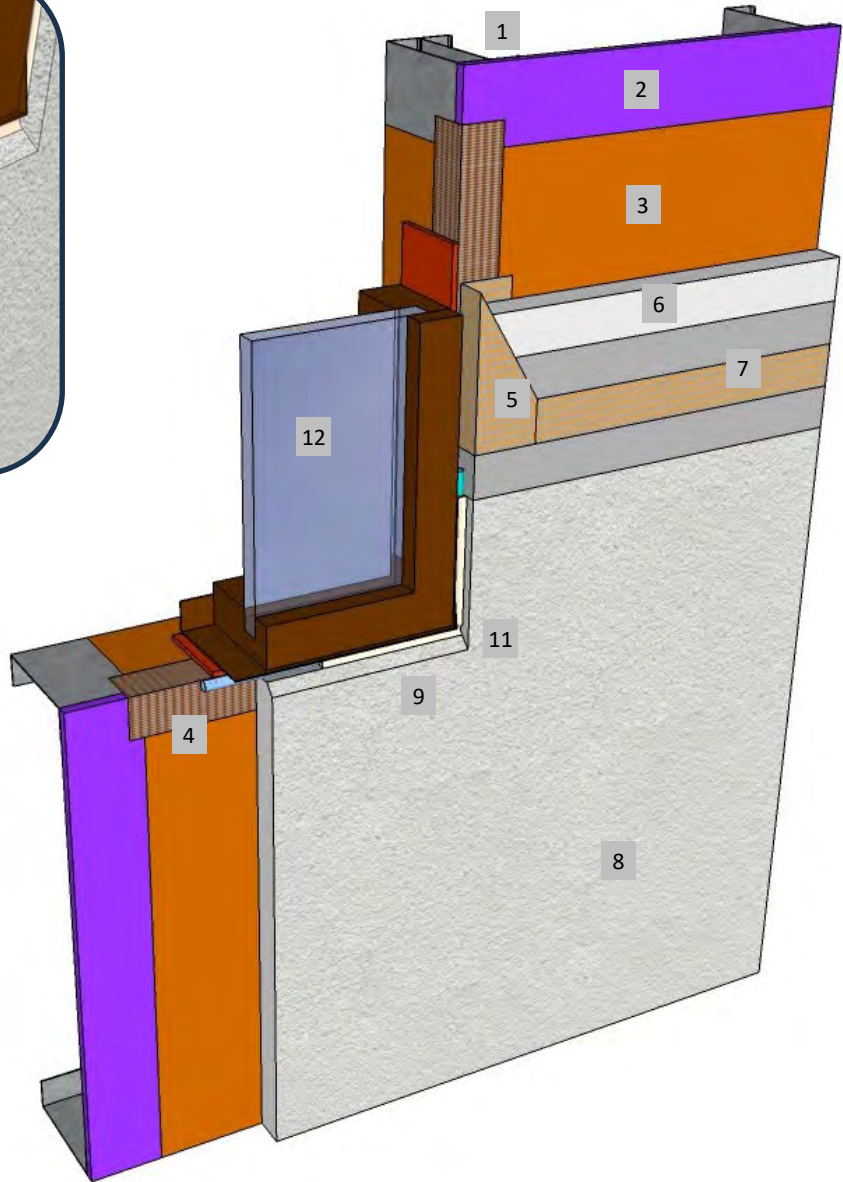
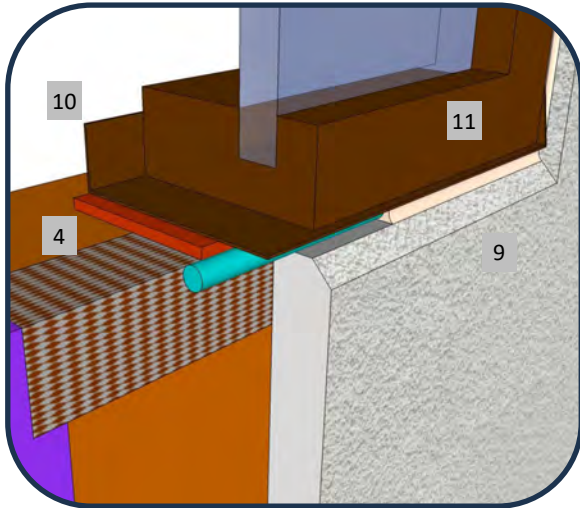

1. FRAMING
2. APPROVED SUBSTRATE
3. ROLLERSHIELD AIR/WATER BARRIER
4. SUPERIORSHIELD FLASHING TAPE INTO OPENING
5. BACKWRAPPED CIFS® SHOWN, EIFS PLASTIC ACCESSORIES ARE OPTIONAL.
6. MASTER WALL INSULATION BOARD ADHERED WITH CHANNELED ADHESIVE
7. MASTER WALL BASE COAT AND MESH
8. SUPERIOR FINISH
9. SLOPE SILLS, 1:2 RECOMMENDED
10. SILL PAN (IF REQUIRED) NOTE: IF SILL PAN DESIGN EXTENDS OVER EIFS IT SHOULD RUN DOWN FACE 2" (51 MM) MIN. WITH LOWER EDGE SEALED
11. 1/2" (12.7 MM) MIN. JAMB SEALANT JOINT & BACKER ROD
12. STOREFRONT WINDOW

RDCIFS-13 TYPICAL STOREFRONT WINDOW SILL

M Master Wall Inc.
Building a Culture of Excellence

PO Box 397 · Fortson · GA · 31808 · 800-755-0825 · masterwall.com

These drawings relay the conceptual conditions of Master Wall® Systems and are not the construction drawings. Ultimately the design and detailing of an entire wall system is the responsibility of a professional. These details will guide the design professional in the use of Master Wall® Products. Master Wall disclaims design, warranty or construction intent or responsibility. Bold or Brand Name = Master Wall® Product. ©2024 Master Wall Inc.®



Master Wall Inc.
Building a Culture of Excellence

**ROLLERSHIELD
DRAINAGE CIFS®**

SYSTEM DETAIL

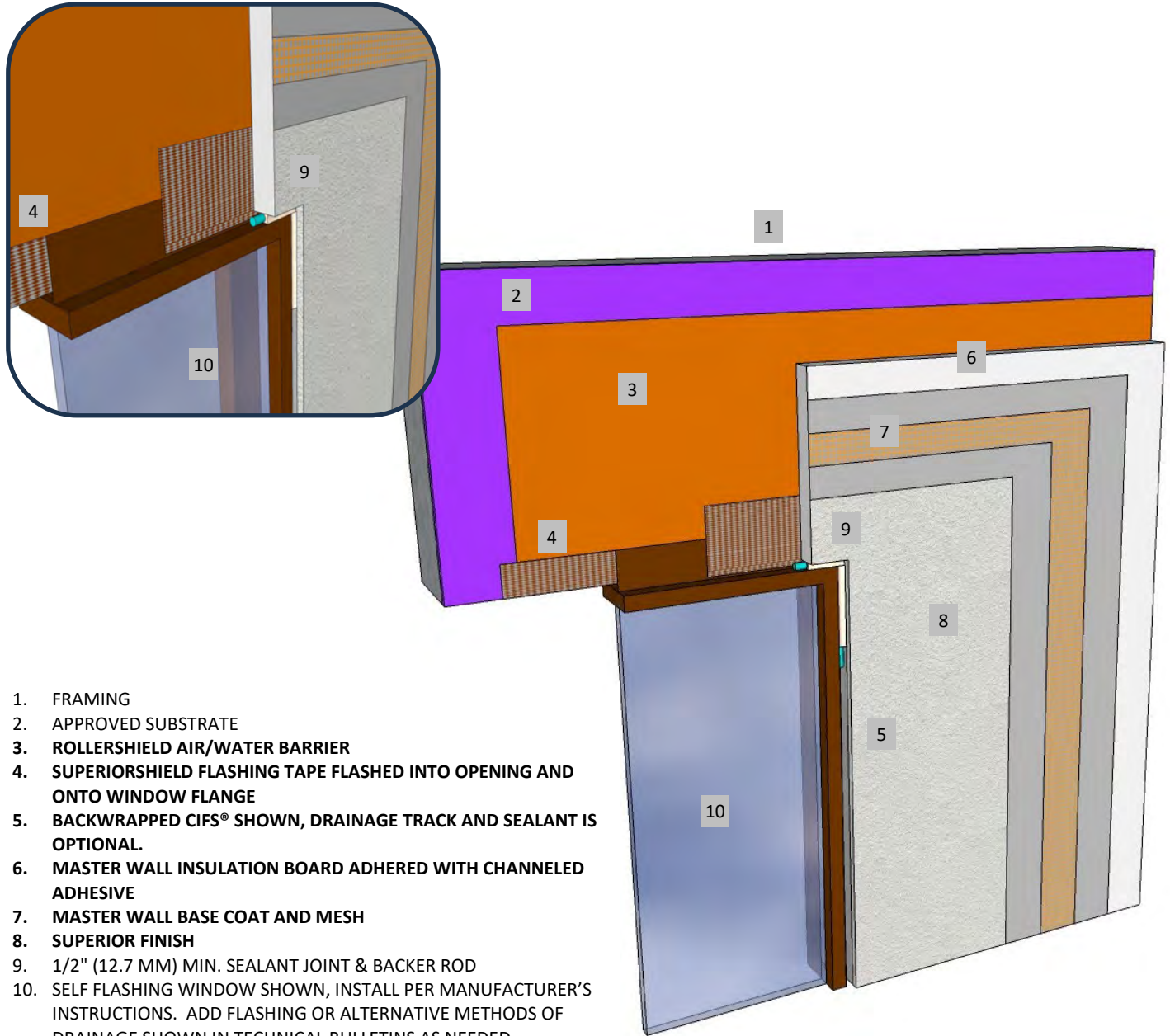

1. FRAMING
2. APPROVED SUBSTRATE
3. ROLLERSHIELD AIR/WATER BARRIER
4. SUPERIORSHIELD FLASHING TAPE FLASHED INTO OPENING AND ONTO WINDOW FLANGE
5. BACKWRAPPED CIFS® SHOWN, DRAINAGE TRACK AND SEALANT IS OPTIONAL.
6. MASTER WALL INSULATION BOARD ADHERED WITH CHanneled ADHESIVE
7. MASTER WALL BASE COAT AND MESH
8. SUPERIOR FINISH
9. 1/2" (12.7 MM) MIN. SEALANT JOINT & BACKER ROD
10. SELF FLASHING WINDOW SHOWN, INSTALL PER MANUFACTURER'S INSTRUCTIONS. ADD FLASHING OR ALTERNATIVE METHODS OF DRAINAGE SHOWN IN TECHNICAL BULLETINS AS NEEDED

RDCIFS-14 TYPICAL SELF-FLASHING FLANGED WINDOW HEAD



PO Box 397 · Fortson · GA · 31808 · 800-755-0825 · masterwall.com

These drawings relay the conceptual conditions of Master Wall® Systems and are not the construction drawings. Ultimately the design and detailing of an entire wall system is the responsibility of a professional. These details will guide the design professional in the use of Master Wall® Products. Master Wall disclaims design, warranty or construction intent or responsibility. Bold or Brand Name = Master Wall® Product. ©2024 Master Wall Inc.®



Master Wall Inc.
Building a Culture of Excellence

**ROLLERSHIELD
DRAINAGE CIFS®**

SYSTEM DETAIL

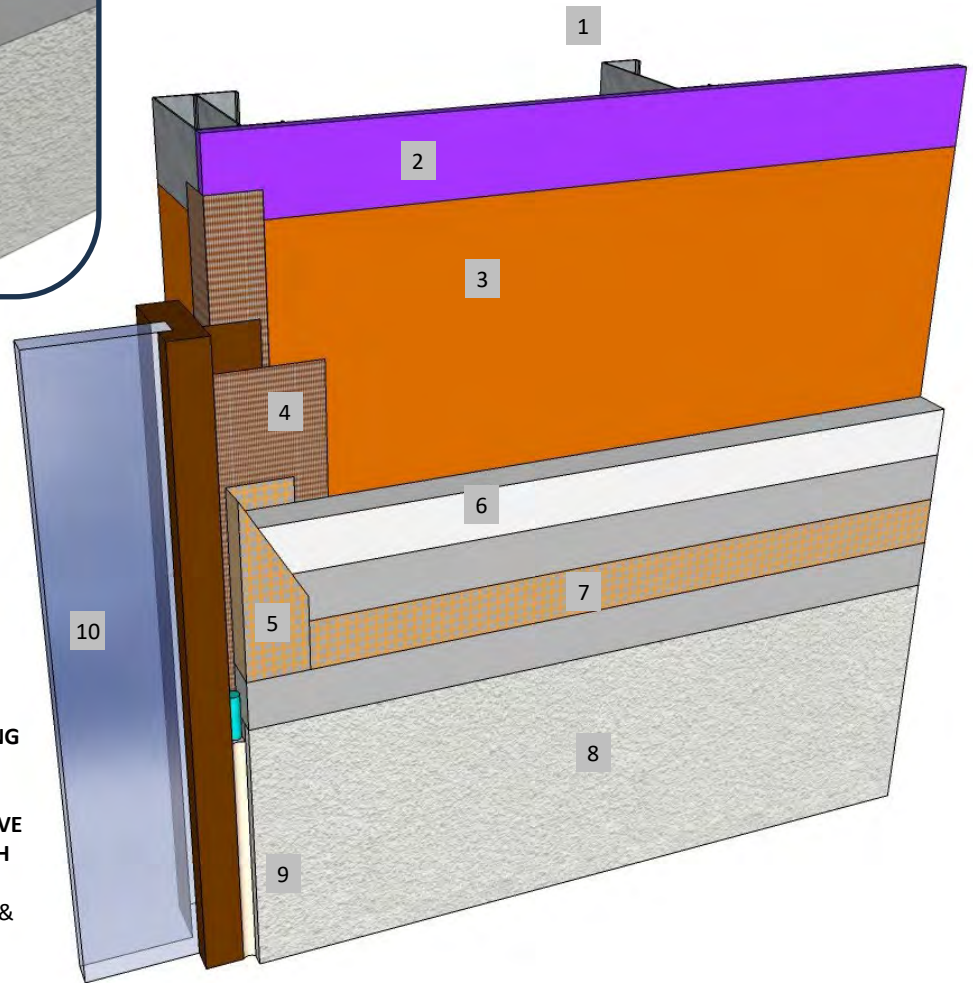
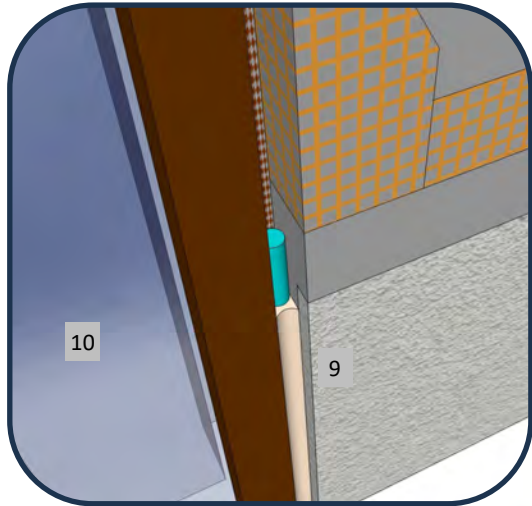

1. FRAMING
2. APPROVED SUBSTRATE
3. ROLLERSHIELD AIR/WATER BARRIER
4. SUPERIORSHIELD FLASHING TAPE FLASHED INTO OPENING AND ONTO WINDOW FLANGE
5. BACKWRAPPED CIFS® SHOWN, CASING BEAD IS OPTIONAL.
6. MASTER WALL INSULATION BOARD ADHERED WITH CHANNELED ADHESIVE
7. MASTER WALL BASE COAT AND MESH
8. SUPERIOR FINISH
9. 1/2" (12.7 MM) MIN. SEALANT JOINT & BACKER ROD
10. SELF FLASHING WINDOW SHOWN, INSTALL PER MANUFACTURER'S INSTRUCTIONS.

RDCIFS-15 FLANGED WINDOW JAMB

M Master Wall Inc.
Building a Culture of Excellence

PO Box 397 · Fortson · GA · 31808 · 800-755-0825 · masterwall.com

These drawings relay the conceptual conditions of Master Wall® Systems and are not the construction drawings. Ultimately the design and detailing of an entire wall system is the responsibility of a professional. These details will guide the design professional in the use of Master Wall® Products. Master Wall disclaims design, warranty or construction intent or responsibility. Bold or Brand Name = Master Wall® Product. ©2024 Master Wall Inc.®



Master Wall Inc.
Building a Culture of Excellence

**ROLLERSHIELD
DRAINAGE CIFS®**

SYSTEM DETAIL

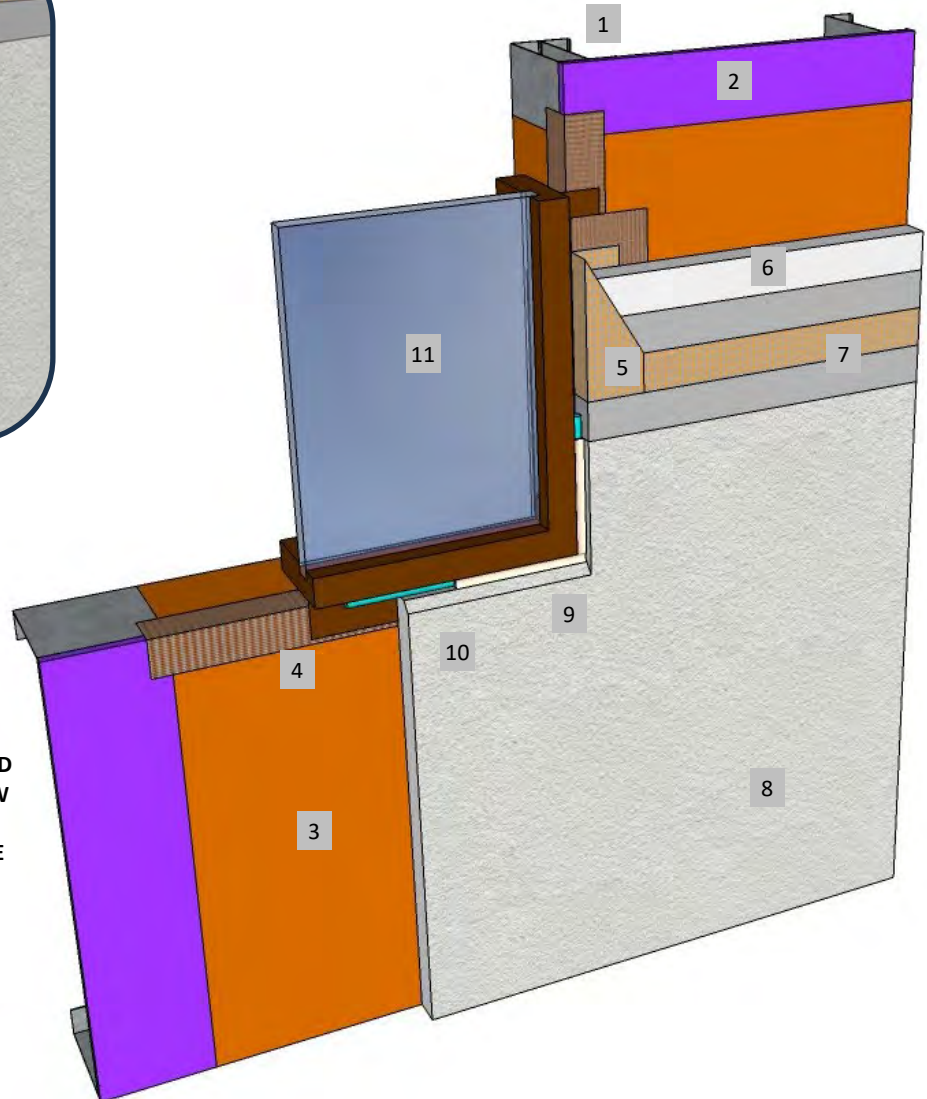
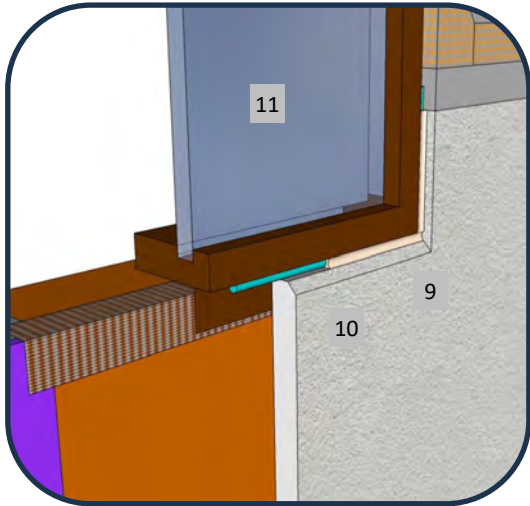

1. FRAMING
2. APPROVED SUBSTRATE
3. ROLLERSHIELD AIR/WATER BARRIER
4. SUPERIORSHIELD FLASHING TAPE FLASHED INTO OPENING, POSSIBLY ONTO WINDOW FLANGE
5. BACKWRAPPED CIFS® SHOWN, DRAINAGE TRACK IS OPTIONAL.
6. MASTER WALL INSULATION BOARD ADHERED WITH CHANNELED ADHESIVE
7. MASTER WALL BASE COAT AND MESH
8. SUPERIOR FINISH
9. 1/2" (12.7 MM) MIN. SEALANT JOINT & BACKER ROD
10. SLOPE EXPOSED WINDOW SILL 1:2 MIN. RECOMMENDED
11. SELF FLASHING WINDOW SHOWN, INSTALL PER MANUFACTURER'S INSTRUCTIONS.

RDCIFS- 16 TYPICAL FLANGED WINDOW SILL

M Master Wall Inc.
Building a Culture of Excellence

PO Box 397 · Fortson · GA · 31808 · 800-755-0825 · masterwall.com

These drawings relay the conceptual conditions of Master Wall® Systems and are not the construction drawings. Ultimately the design and detailing of an entire wall system is the responsibility of a professional. These details will guide the design professional in the use of Master Wall® Products. Master Wall disclaims design, warranty or construction intent or responsibility. Bold or Brand Name = Master Wall® Product. ©2024 Master Wall Inc.®



Master Wall Inc.
Building a Culture of Excellence

**ROLLERSHIELD
DRAINAGE CIFS®**

SYSTEM DETAIL

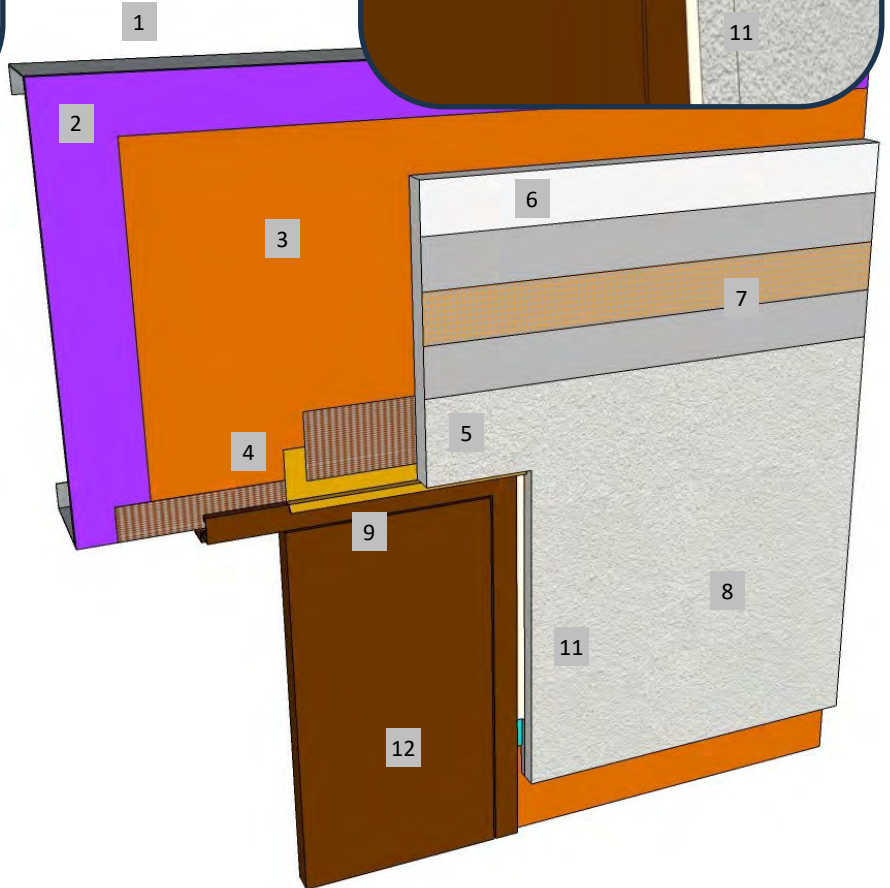
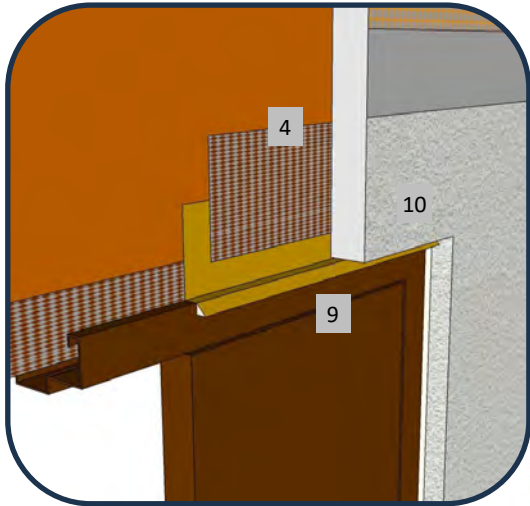

1. FRAMING
2. APPROVED SUBSTRATE
3. ROLLERSHIELD AIR/WATER BARRIER
4. SUPERIORSHIELD FLASHING TAPE FLASHED INTO OPENING AND ONTO DOOR FLASHING
5. BACKWRAPPED CIFS® SHOWN, DRAINAGE TRACK WITH SEALANT IS OPTIONAL.
6. MASTER WALL INSULATION BOARD ADHERED WITH CHANNELED ADHESIVE
7. MASTER WALL BASE COAT AND MESH
8. SUPERIOR FINISH
9. HEAD FLASHING, EXTENDED 1/2" (12.7 MM) BEYOND JAMBS WITH END DAM, SEAL FLASHING TO DOOR FRAME
10. KEEP CIFS® APPROX. 1/8" (3 MM) ABOVE HEAD FLASHING FOR DRAINAGE
11. 1/2" (12.7 MM) MIN. SEALANT JOINT & BACKER ROD @ JAMB
12. HOLLOW METAL DOOR SHOWN, INSTALL PER MANUFACTURER'S INSTRUCTIONS.

RDCIFS-17 TYPICAL HOLLOW METAL DOOR HEAD

M Master Wall Inc.
Building a Culture of Excellence

PO Box 397 · Fortson · GA · 31808 · 800-755-0825 · masterwall.com

These drawings relay the conceptual conditions of Master Wall® Systems and are not the construction drawings. Ultimately the design and detailing of an entire wall system is the responsibility of a professional. These details will guide the design professional in the use of Master Wall® Products. Master Wall disclaims design, warranty or construction intent or responsibility. Bold or Brand Name = Master Wall® Product. ©2024 Master Wall Inc.®



Master Wall Inc.
Building a Culture of Excellence

**ROLLERSHIELD
DRAINAGE CIFS®**

SYSTEM DETAIL

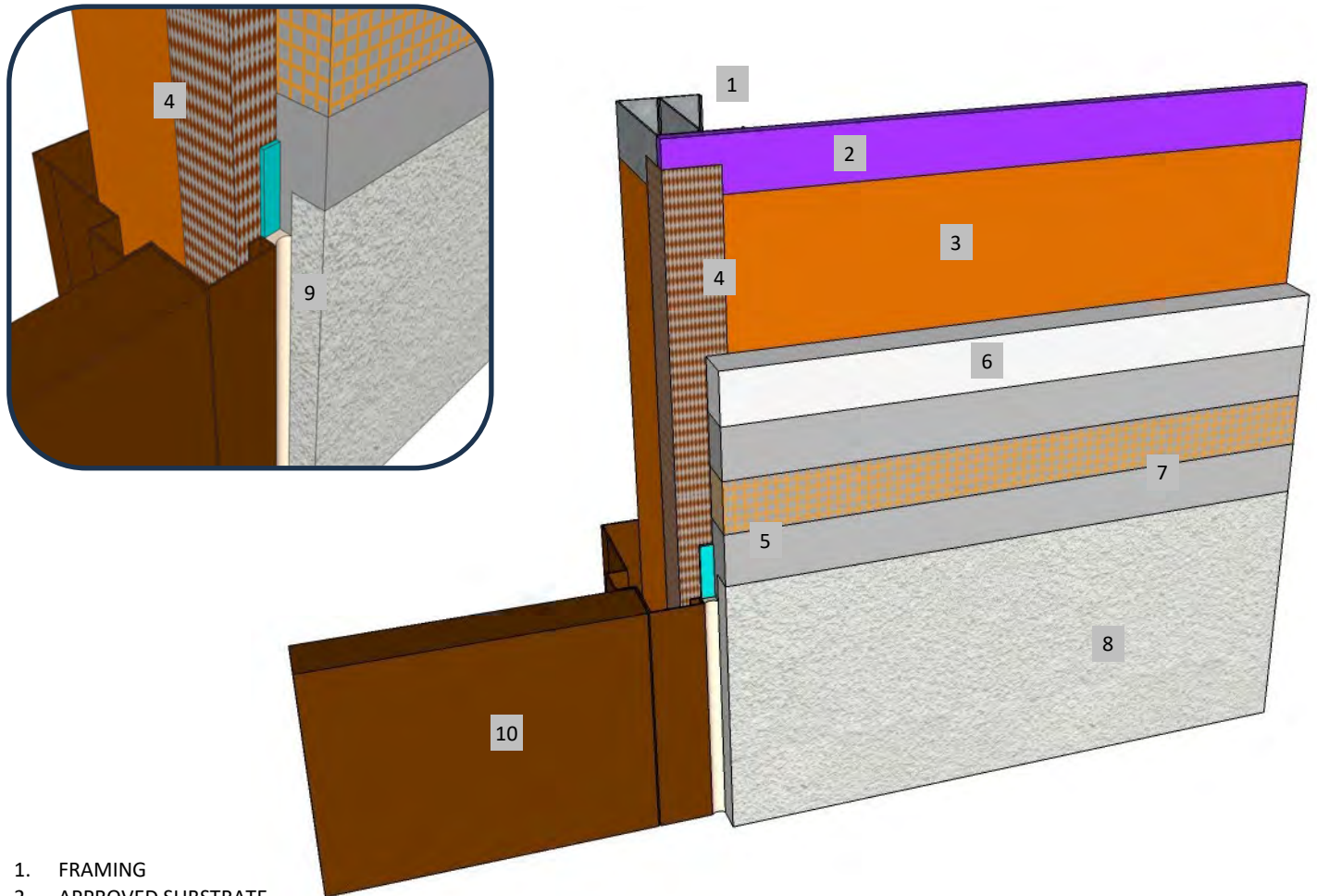

1. FRAMING
2. APPROVED SUBSTRATE
3. ROLLERSHIELD AIR/WATER BARRIER
4. SUPERIORSHIELD FLASHING TAPE FLASHED INTO OPENING AND ONTO DOOR FLASHING
5. BACKWRAPPED CIFS® SHOWN, CASING BEAD IS OPTIONAL.
6. MASTER WALL INSULATION BOARD ADHERED WITH CHANNLED ADHESIVE
7. MASTER WALL BASE COAT AND MESH
8. SUPERIOR FINISH
9. 1/2" (12.7 MM) MIN. SEALANT JOINT & BACKER ROD
10. HOLLOW METAL DOOR SHOWN, INSTALL PER MANUFACTURER'S INSTRUCTIONS.

RDCIFS-18 TYPICAL HOLLOW METAL DOOR JAMB

M Master Wall Inc.
Building a Culture of Excellence

PO Box 397 · Fortson · GA · 31808 · 800-755-0825 · masterwall.com

These drawings relay the conceptual conditions of Master Wall® Systems and are not the construction drawings. Ultimately the design and detailing of an entire wall system is the responsibility of a professional. These details will guide the design professional in the use of Master Wall® Products. Master Wall disclaims design, warranty or construction intent or responsibility. Bold or Brand Name = Master Wall® Product. ©2024 Master Wall Inc.®



Master Wall Inc.
Building a Culture of Excellence

**ROLLERSHIELD
DRAINAGE CIFS®**

SYSTEM DETAIL

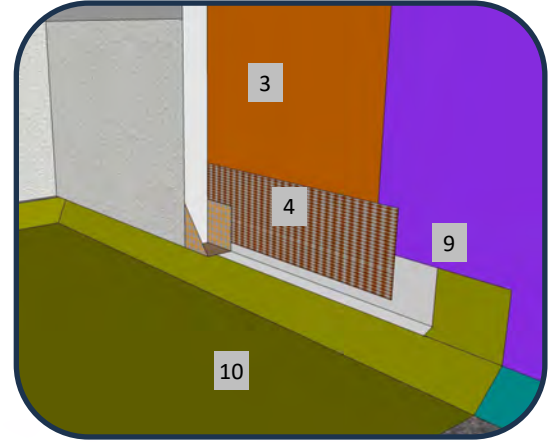
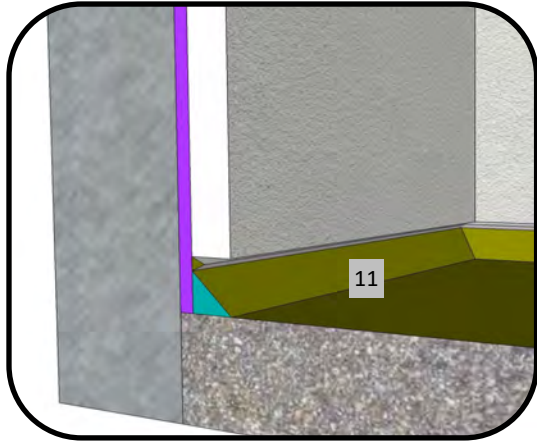

1. FRAMING
2. APPROVED SUBSTRATE
3. ROLLERSHIELD AIR/WATER BARRIER
4. SUPERIORSHIELD FLASHING TAPE FLASHED ONTO DRAINAGE ACCESSORY
5. MASTER WALL INSULATION BOARD ADHERED WITH CHanneled ADHESIVE
6. BACKWRAPPED CIFS® SHOWN, CASING BEAD IS OPTIONAL.
7. MASTER WALL BASE COAT AND MESH
8. SUPERIOR FINISH
9. DRAINAGE ACCESSORY OPTION (SEE DETAILS)
10. WATERPROOF TOPPING
11. RECOMMENDED TO KEEP CIFS® MIN. 3/4" (19 MM) ABOVE WATERPROOFING

RDCIFS-19 DECK FLASHING TERMINATION



PO Box 397 · Fortson · GA · 31808 · 800-755-0825 · masterwall.com

These drawings relay the conceptual conditions of Master Wall® Systems and are not the construction drawings. Ultimately the design and detailing of an entire wall system is the responsibility of a professional. These details will guide the design professional in the use of Master Wall® Products. Master Wall disclaims design, warranty or construction intent or responsibility. Bold or Brand Name = Master Wall® Product. ©2024 Master Wall Inc.®



Master Wall Inc.
Building a Culture of Excellence

**ROLLERSHIELD
DRAINAGE CIFS®**

SYSTEM DETAIL

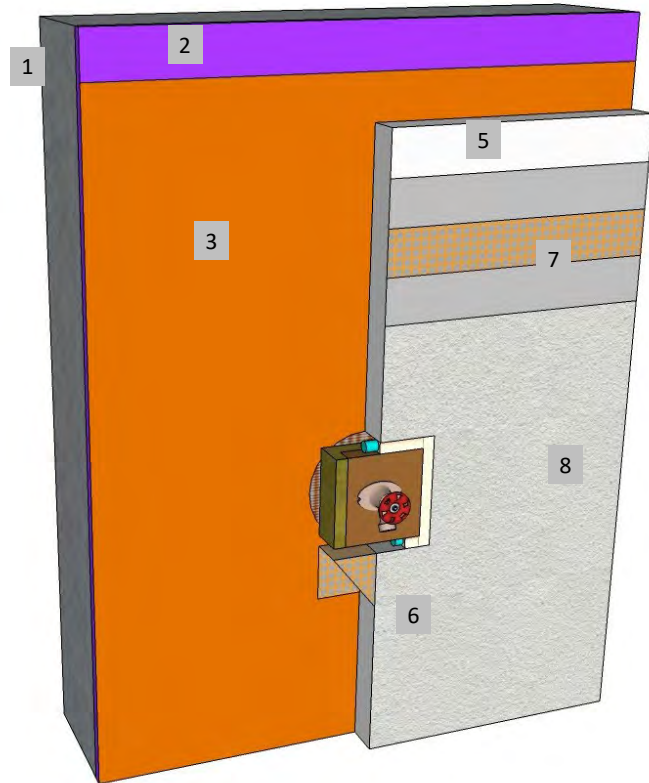
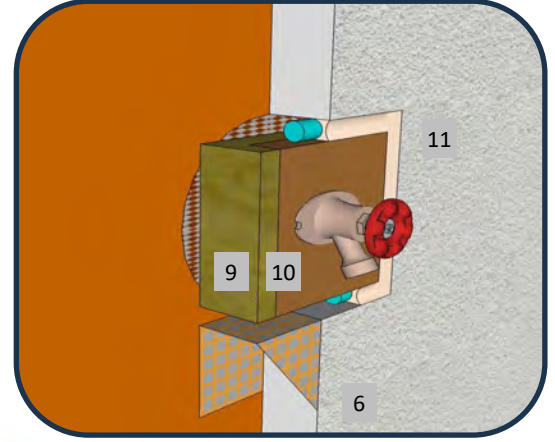
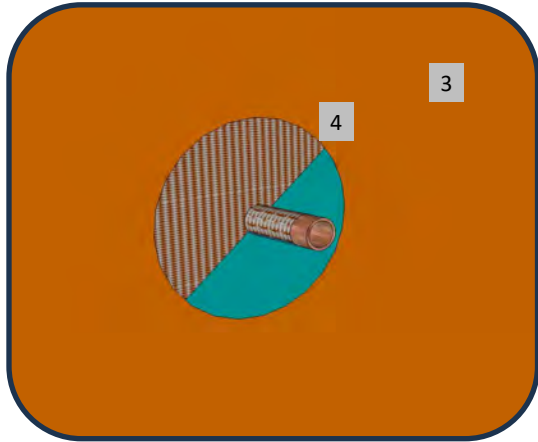

1. FRAMING
2. APPROVED SUBSTRATE
3. ROLLERSHIELD AIR/WATER BARRIER
4. SUPERIORFLASH OR SUPERIORSHIELD FLASHING TAPE AROUND PIPE PENETRATION
5. MASTER WALL INSULATION BOARD ADHERED WITH CHANNELED ADHESIVE
6. BACKWRAPPED CIFS® SHOWN, CASING BEAD IS OPTIONAL.
7. MASTER WALL BASE COAT AND MESH
8. SUPERIOR FINISH
9. WOOD BLOCKING
10. METAL CLOSURE
11. 1/2" (12.7 MM) MIN. SEALANT JOINT

RDCIFS-20 TYPICAL PLUMBING SPIGOT DETAIL

M Master Wall Inc.
Building a Culture of Excellence

PO Box 397 · Fortson · GA · 31808 · 800-755-0825 · masterwall.com

These drawings relay the conceptual conditions of Master Wall® Systems and are not the construction drawings. Ultimately the design and detailing of an entire wall system is the responsibility of a professional. These details will guide the design professional in the use of Master Wall® Products. Master Wall disclaims design, warranty or construction intent or responsibility. Bold or Brand Name = Master Wall® Product. ©2024 Master Wall Inc.®



Master Wall Inc.
Building a Culture of Excellence

**ROLLERSHIELD
DRAINAGE CIFS®**

SYSTEM DETAIL

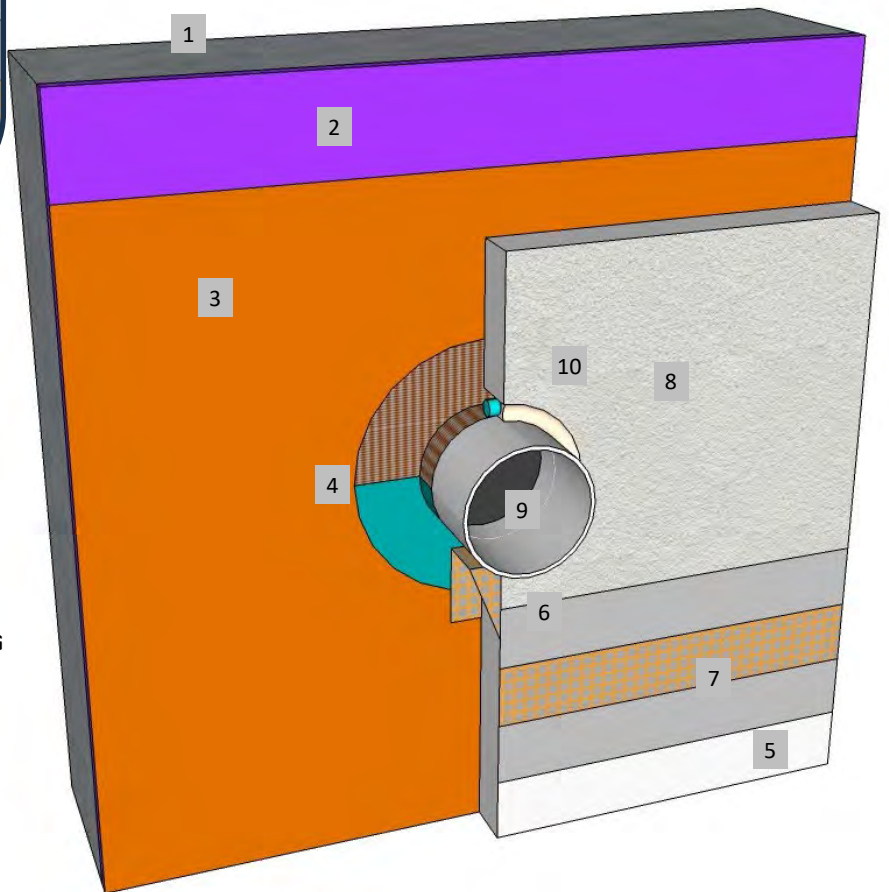
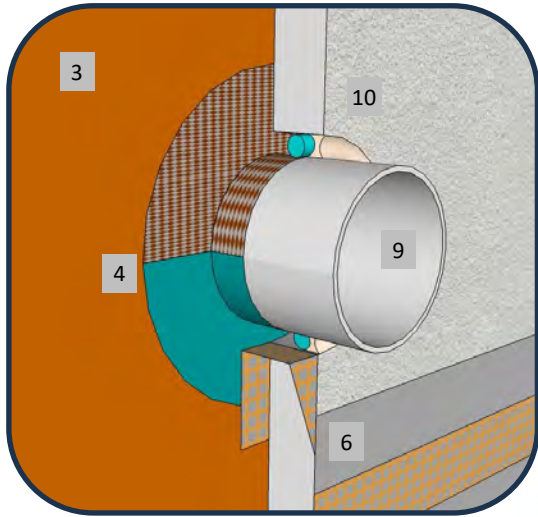

1. FRAMING
2. APPROVED SUBSTRATE
3. ROLLERSHIELD AIR/WATER BARRIER
4. SUPERIORFLASH OR SUPERIORSHIELD FLASHING TAPE AROUND PIPE PENETRATION
5. MASTER WALL INSULATION BOARD ADHERED WITH CHANNELED ADHESIVE
6. BACKWRAPPED CIFS® SHOWN
7. MASTER WALL BASE COAT AND MESH
8. SUPERIOR FINISH
9. PIPE PENETRATION
10. 1/2" (12.7 MM) MIN. SEALANT JOINT

RDCIFS-21 TYPICAL PIPE PENETRATION DETAIL

M Master Wall Inc.
Building a Culture of Excellence

PO Box 397 · Fortson · GA · 31808 · 800-755-0825 · masterwall.com

These drawings relay the conceptual conditions of Master Wall® Systems and are not the construction drawings. Ultimately the design and detailing of an entire wall system is the responsibility of a professional. These details will guide the design professional in the use of Master Wall® Products. Master Wall disclaims design, warranty or construction intent or responsibility. Bold or Brand Name = Master Wall® Product. ©2024 Master Wall Inc.®



Master Wall Inc.
Building a Culture of Excellence

**ROLLERSHIELD
DRAINAGE CIFS®**

SYSTEM DETAIL

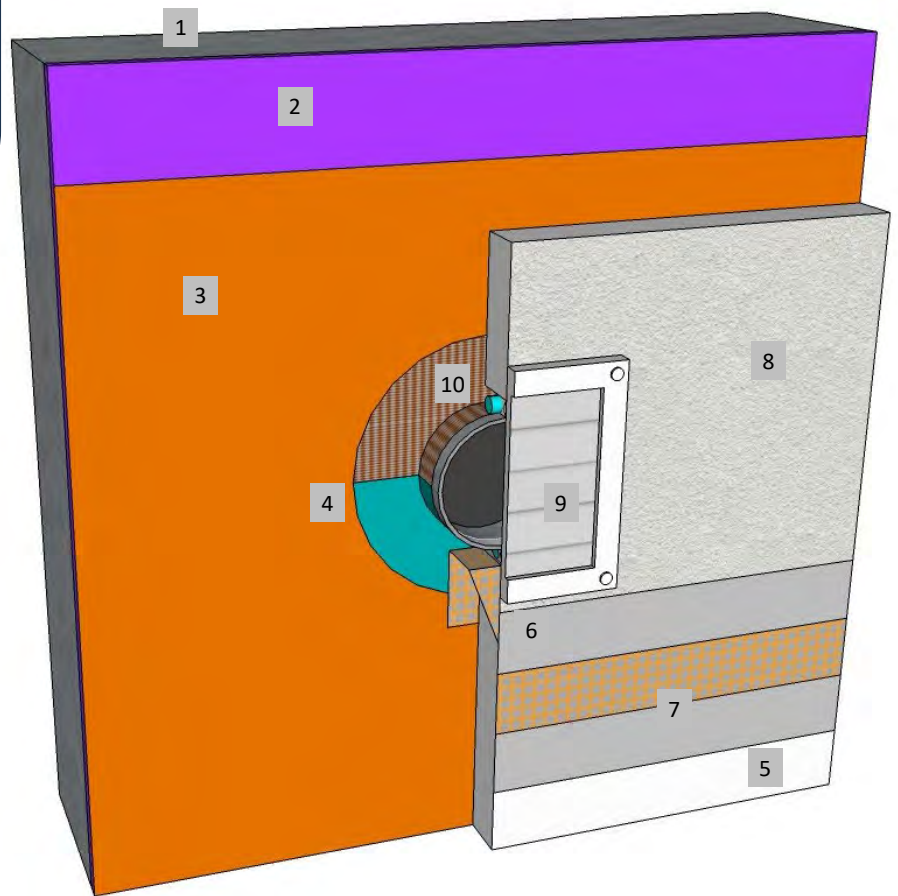
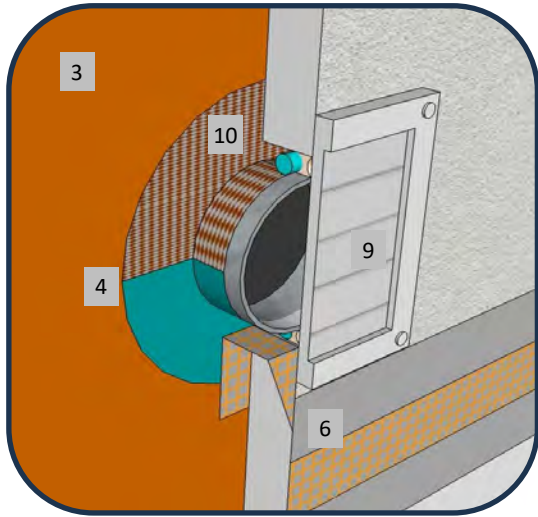

1. FRAMING
2. APPROVED SUBSTRATE
3. ROLLERSHIELD AIR/WATER BARRIER
4. SUPERIORFLASH OR SUPERIORSHIELD FLASHING TAPE AROUND PIPE PENETRATION
5. MASTER WALL INSULATION BOARD ADHERED WITH CHANNELED ADHESIVE
6. BACKWRAPPED CIFS® SHOWN
7. MASTER WALL BASE COAT AND MESH
8. SUPERIOR FINISH
9. VENT SET IN SEALANT AND SECURED TO STRUCTURAL SUPPORT, TAKE CARE TO SNUG FIT TO WALL SURFACE.
10. 1/2" (12.7 MM) MIN. SEALANT JOINT

RDCIFS-22 TYPICAL DRYER VENT DETAIL

M Master Wall Inc.
Building a Culture of Excellence

PO Box 397 · Fortson · GA · 31808 · 800-755-0825 · masterwall.com

These drawings relay the conceptual conditions of Master Wall® Systems and are not the construction drawings. Ultimately the design and detailing of an entire wall system is the responsibility of a professional. These details will guide the design professional in the use of Master Wall® Products. Master Wall disclaims design, warranty or construction intent or responsibility. Bold or Brand Name = Master Wall® Product. ©2024 Master Wall Inc.®



Master Wall Inc.
Building a Culture of Excellence

**ROLLERSHIELD
DRAINAGE CIFS®**

SYSTEM DETAIL

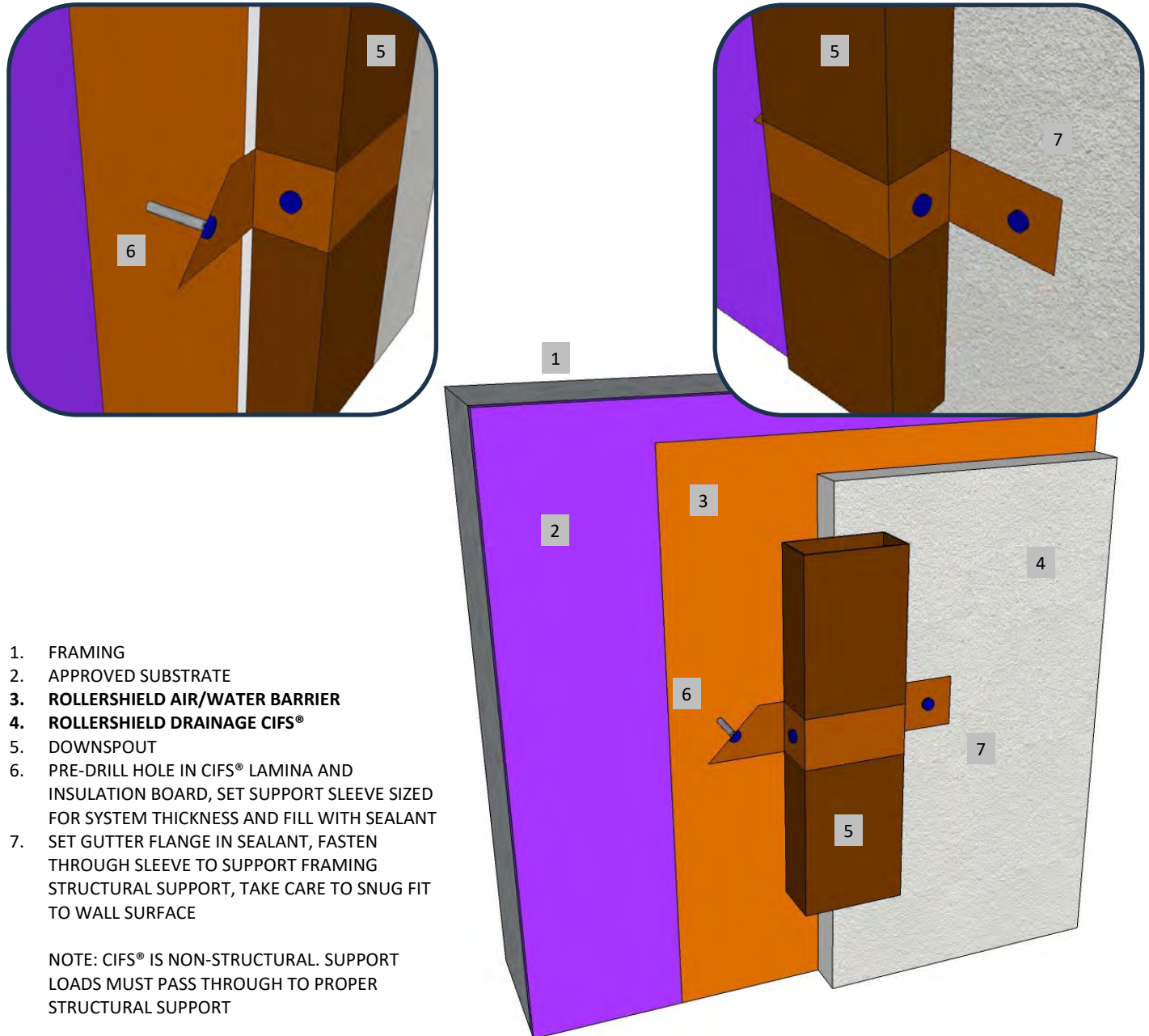

RDCIFS-23 TYPICAL DOWNSPOUT ATTACHMENT

M Master Wall Inc.
Building a Culture of Excellence

PO Box 397 · Fortson · GA · 31808 · 800-755-0825 · masterwall.com

These drawings relay the conceptual conditions of Master Wall® Systems and are not the construction drawings. Ultimately the design and detailing of an entire wall system is the responsibility of a professional. These details will guide the design professional in the use of Master Wall® Products. Master Wall disclaims design, warranty or construction intent or responsibility. Bold or Brand Name = Master Wall® Product. ©2024 Master Wall Inc.®



Master Wall Inc.
Building a Culture of Excellence

**ROLLERSHIELD
DRAINAGE CIFS®**

SYSTEM DETAIL

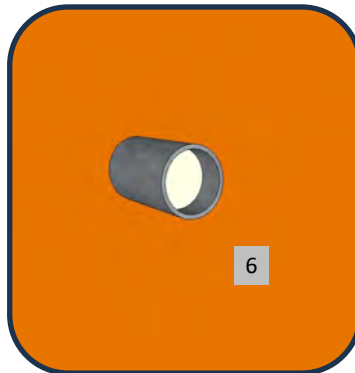

1. FRAMING, SIGNAGE SUPPORT AND APPROVED SUBSTRATE
2. **ROLLERSHIELD AIR/WATER BARRIER**
3. **ROLLERSHIELD DRAINAGE CIFS®**
4. SIGNAGE
5. PRE-DRILL HOLE THE SIZE OF THE STRUCTURAL SLEEVE THROUGH CIFS® (NOT SHOWN) AND SUBSTRATE TO STRUCTURAL SUPPORT
6. INSERT STRUCTURAL SLEEVE SIZED FOR SUBSTRATE, INSULATION AND LAMINA THICKNESS AND FILL WITH SEALANT
7. SET OVERSIZE WASHER IN SEALANT
8. INSTALL A STRUCTURAL SPACER TO VENTILATE BEHIND THE SIGNAGE (APPROXIMATELY 1" OR 25 MM) AND FASTEN SIGNAGE TO THE STRUCTURAL SUPPORT

NOTE: CIFS® IS NON-STRUCTURAL. SUPPORT LOADS MUST PASS THROUGH TO PROPER STRUCTURAL SUPPORT

RDCIFS-24 TYPICAL SIGNAGE ATTACHMENT

M Master Wall Inc.
Building a Culture of Excellence

These drawings relay the conceptual conditions of Master Wall® Systems and are not the construction drawings. Ultimately the design and detailing of an entire wall system is the responsibility of a professional. These details will guide the design professional in the use of Master Wall® Products. Master Wall disclaims design, warranty or construction intent or responsibility. Bold or Brand Name = Master Wall® Product. ©2024 Master Wall Inc.®



Master Wall Inc.
Building a Culture of Excellence

**ROLLERSHIELD
DRAINAGE CIFS®**

SYSTEM DETAIL

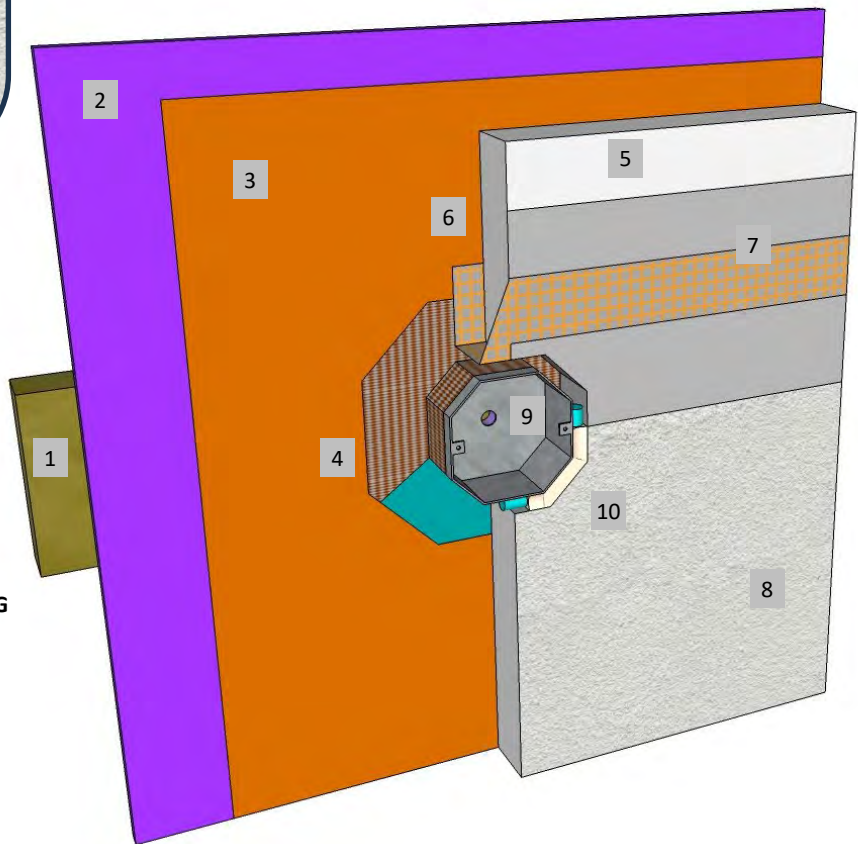
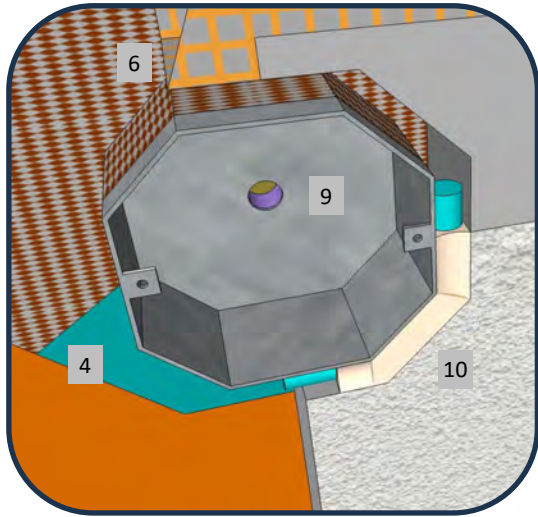

1. FRAMING AND FIXTURE SUPPORT
2. APPROVED SUBSTRATE
3. ROLLERSHIELD AIR/WATER BARRIER
4. SUPERIORFLASH OR SUPERIORSHIELD FLASHING TAPE AROUND WATERPROOF FIXTURE HOUSING
5. MASTER WALL INSULATION BOARD ADHERED WITH CHANNELED ADHESIVE
6. BACKWRAPPED CIFS® SHOWN
7. MASTER WALL BASE COAT AND MESH
8. SUPERIOR FINISH
9. FIXTURE
10. 1/2" (12.7 MM) MIN. SEALANT JOINT

RDCIFS-25 TYPICAL FIXTURE ATTACHMENT



Master Wall Inc.
Building a Culture of Excellence



Master Wall Inc.
Building a Culture of Excellence

**ROLLERSHIELD
DRAINAGE CIFS®**

SYSTEM DETAIL

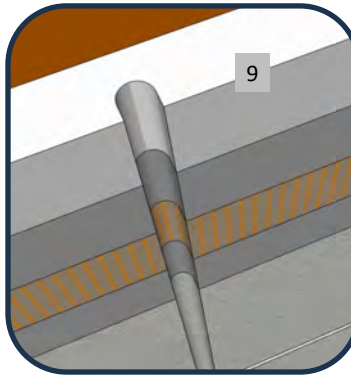
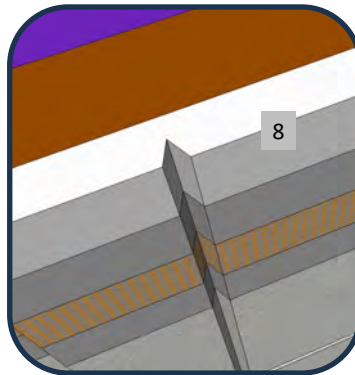
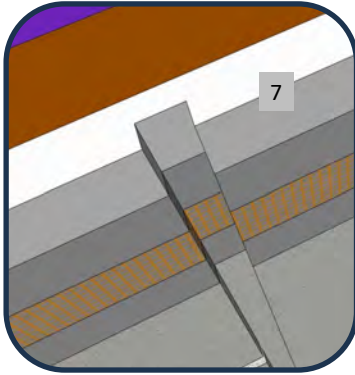

1. FRAMING
2. APPROVED SUBSTRATE
3. ROLLERSHIELD AIR/WATER BARRIER
4. MASTER WALL INSULATION BOARD ADHERED WITH CHANNELED ADHESIVE
5. MASTER WALL BASE COAT AND MESH
6. SUPERIOR FINISH
7. 3/4" DEEP BY 1-1/2" WIDE (19 X 38 MM) SQUARE GROOVE SHOWN*
8. 3/4" DEEP BY 3/4" WIDE (19 X 19 MM) V-GROOVE SHOWN*
9. 3/4" DEEP BY 3/4" WIDE (19 X 19 MM) U-GROOVE SHOWN*
10. SLOPE HORIZONTAL JOINTS TO SHED WATER, 1:2 MIN. RECOMMENDED

*MAINTAIN 3/4" (19 MM) MINIMUM INSULATION THICKNESS UNDER JOINTS

NOTE: AESTHETIC JOINTS ARE DECORATIVE AND NOT A STRUCTURAL COMPONENT OF THE WALL SYSTEM

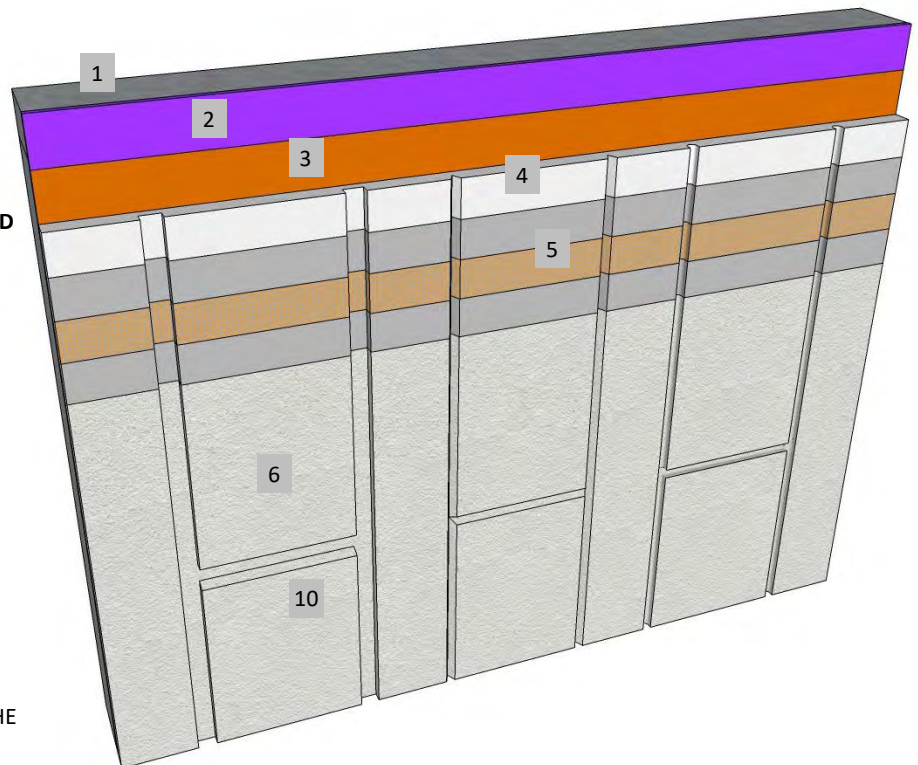

RDCIFS- 26 TYPICAL AESTHETIC JOINTS

M Master Wall Inc.
Building a Culture of Excellence

PO Box 397 · Fortson · GA · 31808 · 800-755-0825 · masterwall.com

These drawings relay the conceptual conditions of Master Wall® Systems and are not the construction drawings. Ultimately the design and detailing of an entire wall system is the responsibility of a professional. These details will guide the design professional in the use of Master Wall® Products. Master Wall disclaims design, warranty or construction intent or responsibility. Bold or Brand Name = Master Wall® Product. ©2024 Master Wall Inc.®



Master Wall Inc.
Building a Culture of Excellence

**ROLLERSHIELD
DRAINAGE CIFS®**

SYSTEM DETAIL

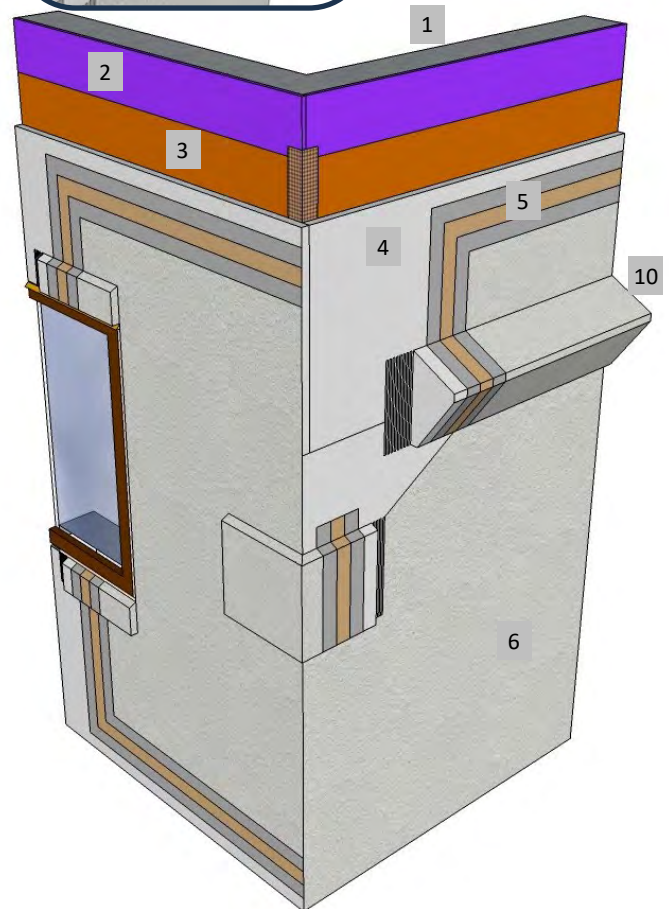
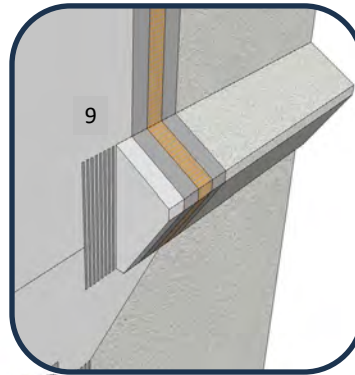
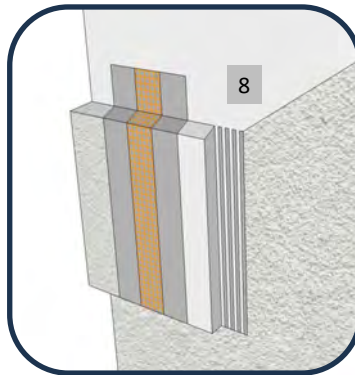
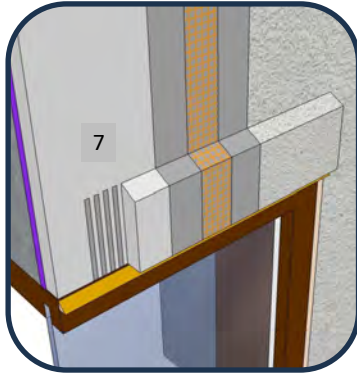

1. FRAMING
2. APPROVED SUBSTRATE
3. ROLLERSHIELD AIR/WATER BARRIER
4. MASTER WALL INSULATION BOARD ADHERED WITH CHANNELED ADHESIVE
5. MASTER WALL BASE COAT AND MESH
6. SUPERIOR FINISH
7. TRIM BAND AT WINDOW HEAD, ADHERE WITH MASTER WALL ADHESIVE
8. DECORATIVE QUOIN, ADHERE WITH MASTER WALL ADHESIVE
9. DECORATIVE BANDING, ADHERE WITH MASTER WALL ADHESIVE
10. SLOPE HORIZONTAL PROJECTIONS TO SHED WATER, 1:2 MIN. RECOMMENDED

RDCIFS- 27 TYPICAL AESTHETIC PROJECTION

M Master Wall Inc.
Building a Culture of Excellence

PO Box 397 · Fortson · GA · 31808 · 800-755-0825 · masterwall.com

These drawings relay the conceptual conditions of Master Wall® Systems and are not the construction drawings. Ultimately the design and detailing of an entire wall system is the responsibility of a professional. These details will guide the design professional in the use of Master Wall® Products. Master Wall disclaims design, warranty or construction intent or responsibility. Bold or Brand Name = Master Wall® Product. ©2024 Master Wall Inc.®



Master Wall Inc.
Building a Culture of Excellence

**ROLLERSHIELD
DRAINAGE CIFS®**

SYSTEM DETAIL

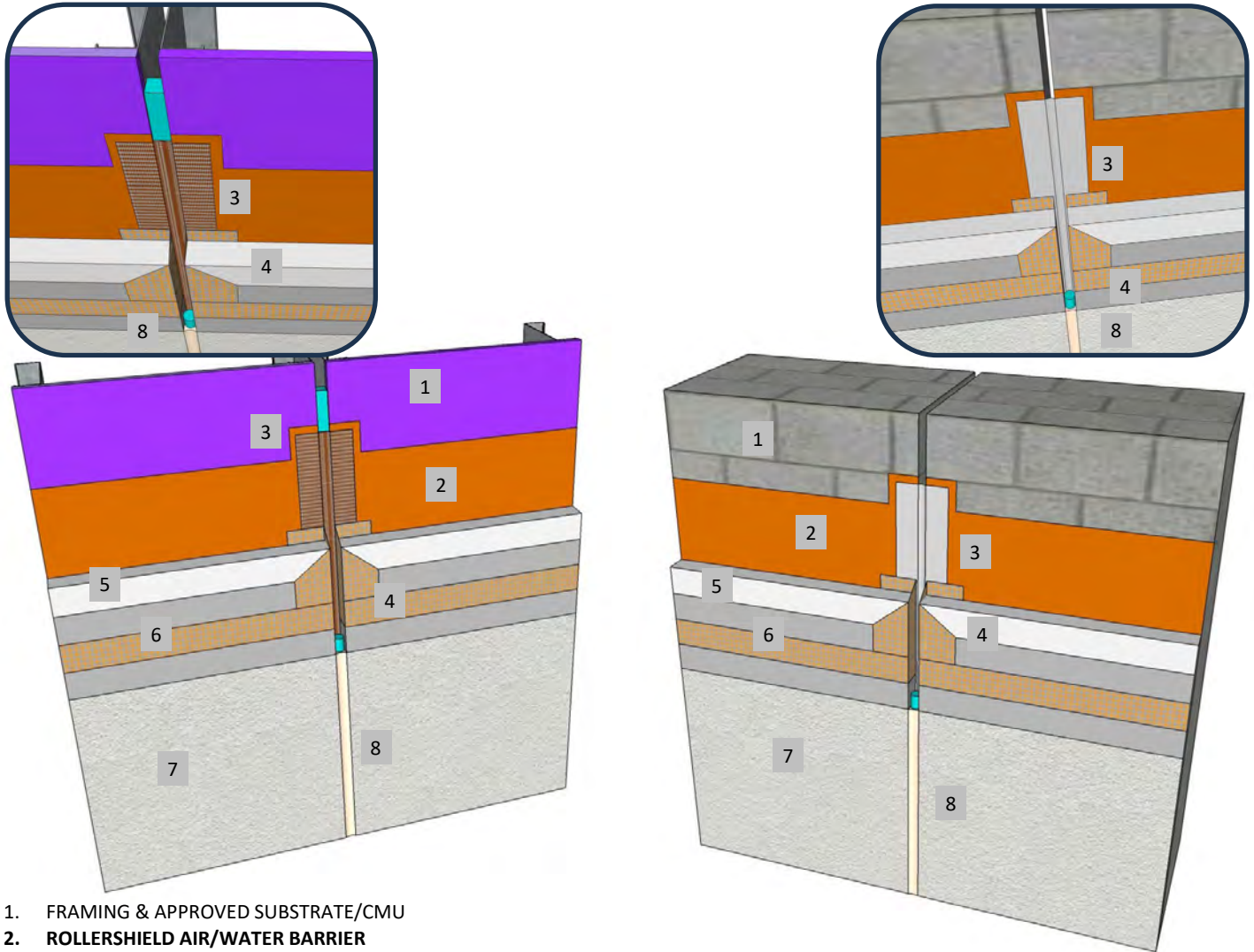

1. FRAMING & APPROVED SUBSTRATE/CMU
2. ROLLERSHIELD AIR/WATER BARRIER
3. EXPANSION BRIDGE: SUPERIORSHIELD FLASHING TAPE/SUPERIORFLASH WITH BACKING OR WEATHERSTOP TAPE
4. BACKWRAPPED CIFS® SHOWN, EIFS PLASTIC ACCESSORIES ARE OPTIONAL
5. MASTER WALL INSULATION BOARD ADHERED WITH CHANNELED ADHESIVE
6. MASTER WALL BASE COAT AND MESH
7. SUPERIOR FINISH
8. SEALANT JOINT SIZED FOR ANTICIPATED MOVEMENT, 3/4" (19 MM) MIN.

RDCIFS-28 VERTICAL EXPANSION JOINT



PO Box 397 · Fortson · GA · 31808 · 800-755-0825 · masterwall.com

These drawings relay the conceptual conditions of Master Wall® Systems and are not the construction drawings. Ultimately the design and detailing of an entire wall system is the responsibility of a professional. These details will guide the design professional in the use of Master Wall® Products. Master Wall disclaims design, warranty or construction intent or responsibility. Bold or Brand Name = Master Wall® Product. ©2024 Master Wall Inc.®



Master Wall Inc.
Building a Culture of Excellence

**ROLLERSHIELD
DRAINAGE CIFS®**

SYSTEM DETAIL

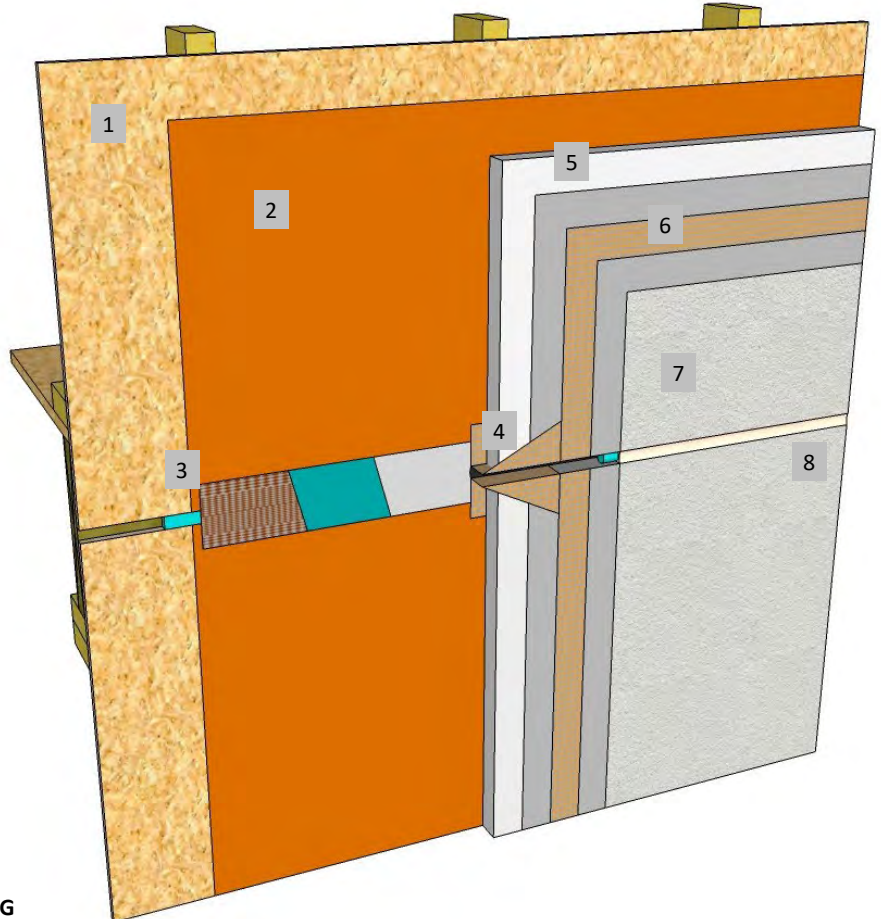
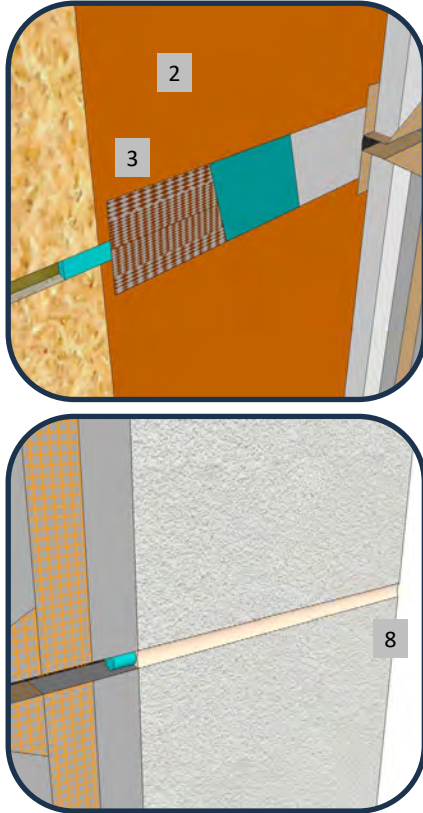

1. FRAMING & APPROVED SUBSTRATE
2. ROLLERSHIELD AIR/WATER BARRIER
3. EXPANSION BRIDGE: SUPERIORSHIELD FLASHING TAPE/SUPERIORFLASH WITH BACKING OR WEATHERSTOP TAPE
4. BACKWRAPPED CIFS® SHOWN, EIFS PLASTIC ACCESSORIES ARE OPTIONAL
5. MASTER WALL INSULATION BOARD ADHERED WITH CHANNELED ADHESIVE
6. MASTER WALL BASE COAT AND MESH
7. SUPERIOR FINISH
8. SEALANT JOINT SIZED FOR ANTICIPATED MOVEMENT, 3/4" (19 MM) MIN.

NOTE: DETAIL NEEDED WHEN 2X FRAMING MEMBERS ARE USED AS FLOOR FRAMING DUE TO CROSS-GRAIN SHRINKAGE. LIKELY NOT NEEDED WITH ENGINEERED FRAMING (VERIFY WITH MFR. & SEE TECHNICAL BULLETIN)

RDCIFS-29 HORIZONTAL EXPANSION JOINT - WOOD FRAME





Master Wall Inc.
Building a Culture of Excellence

**ROLLERSHIELD
DRAINAGE CIFS®**

SYSTEM DETAIL

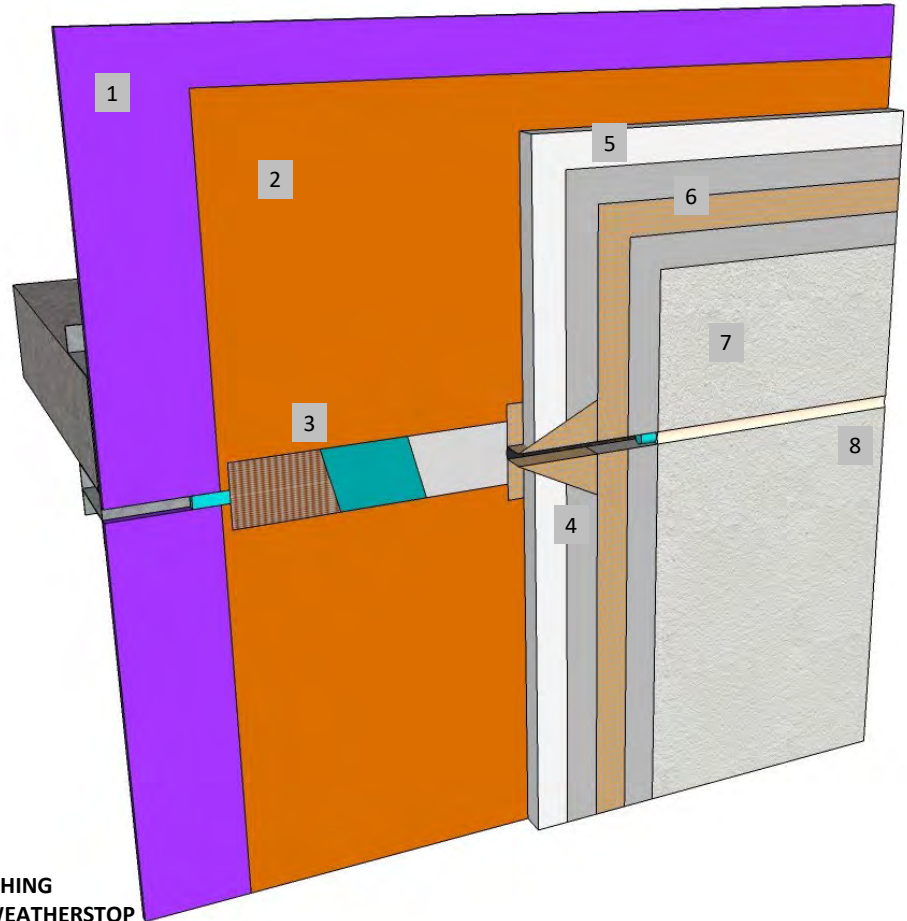
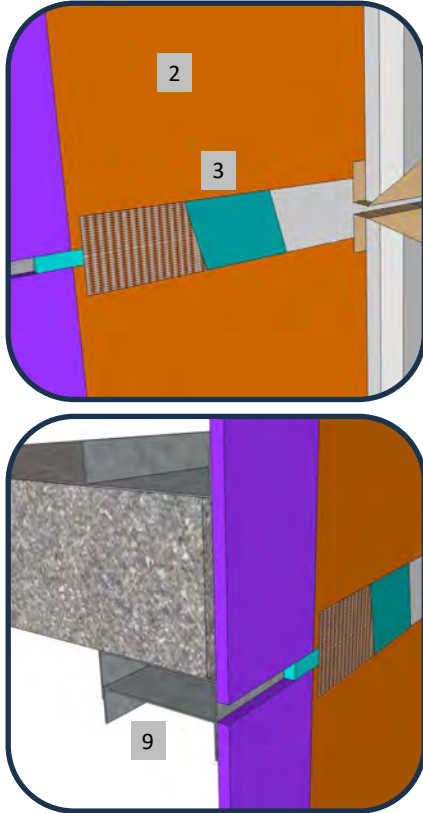

1. FRAMING & APPROVED SUBSTRATE
2. ROLLERSHIELD AIR/WATER BARRIER
3. EXPANSION BRIDGE: SUPERIORSHIELD FLASHING TAPE/SUPERIORFLASH WITH BACKING OR WEATHERSTOP TAPE
4. BACKWRAPPED CIFS® SHOWN, EIFS PLASTIC ACCESSORIES ARE OPTIONAL
5. MASTER WALL INSULATION BOARD ADHERED WITH CHANNELED ADHESIVE
6. MASTER WALL BASE COAT AND MESH
7. SUPERIOR FINISH
8. SEALANT JOINT SIZED FOR ANTICIPATED MOVEMENT, 3/4" (19 MM) MIN.
9. METAL FRAMING SLIP JOINT, MOVEMENT DEFINED BY A/E

RDCIFS-30 HORIZONTAL EXPANSION JOINT - METAL FRAME





Master Wall Inc.
Building a Culture of Excellence

**ROLLERSHIELD
DRAINAGE CIFS®**

SYSTEM DETAIL

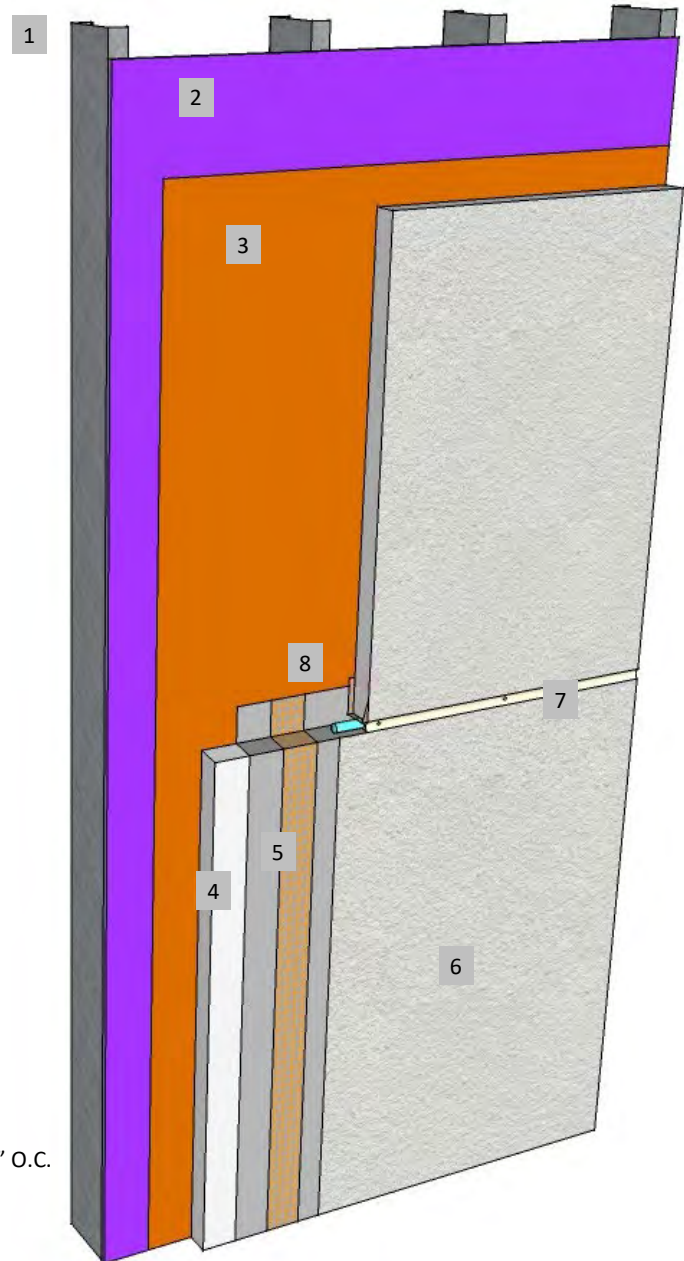
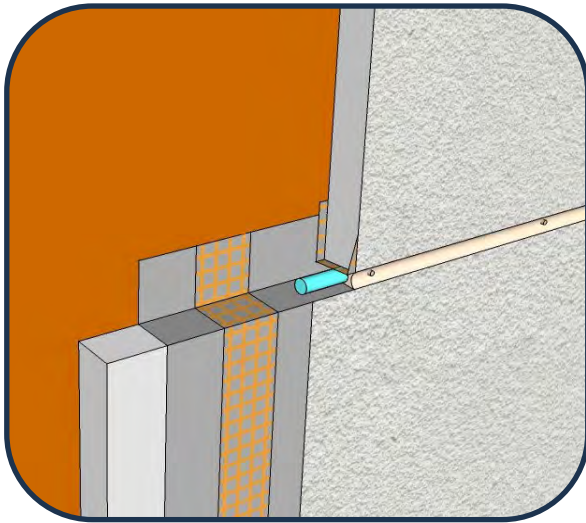

1. FRAMING AND SHEATHING
2. APPROVED SUBSTRATE
3. ROLLERSHIELD AIR/WATER BARRIER
4. AGGRE-FLEX INSULATION BOARD
5. MASTER WALL BASE COAT AND MESH
6. SUPERIOR FINISH
7. SEALANT JOINT, 3/4" (19 MM) MIN. WITH WEEP TUBES @ 24" O.C.
8. EXTEND BASE COAT AND MESH 2-1/2" (63 MM) MIN. ONTO SUBSTRATE

RDCIFS-31 FLOOR LINE DRAINAGE

M Master Wall Inc.
Building a Culture of Excellence

PO Box 397 · Fortson · GA · 31808 · 800-755-0825 · masterwall.com

These drawings relay the conceptual conditions of Master Wall® Systems and are not the construction drawings. Ultimately the design and detailing of an entire wall system is the responsibility of a professional. These details will guide the design professional in the use of Master Wall® Products. Master Wall disclaims design, warranty or construction intent or responsibility. Bold or Brand Name = Master Wall® Product. ©2024 Master Wall Inc.®



Master Wall Inc.
Building a Culture of Excellence

**ROLLERSHIELD
DRAINAGE CIFS®**

SYSTEM DETAIL

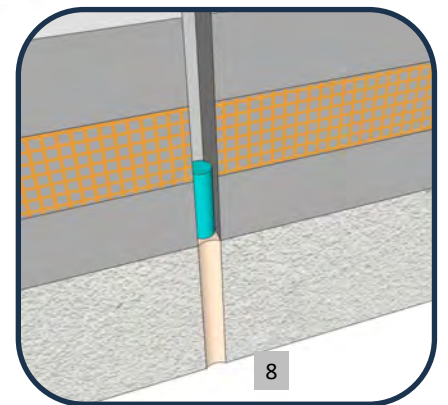
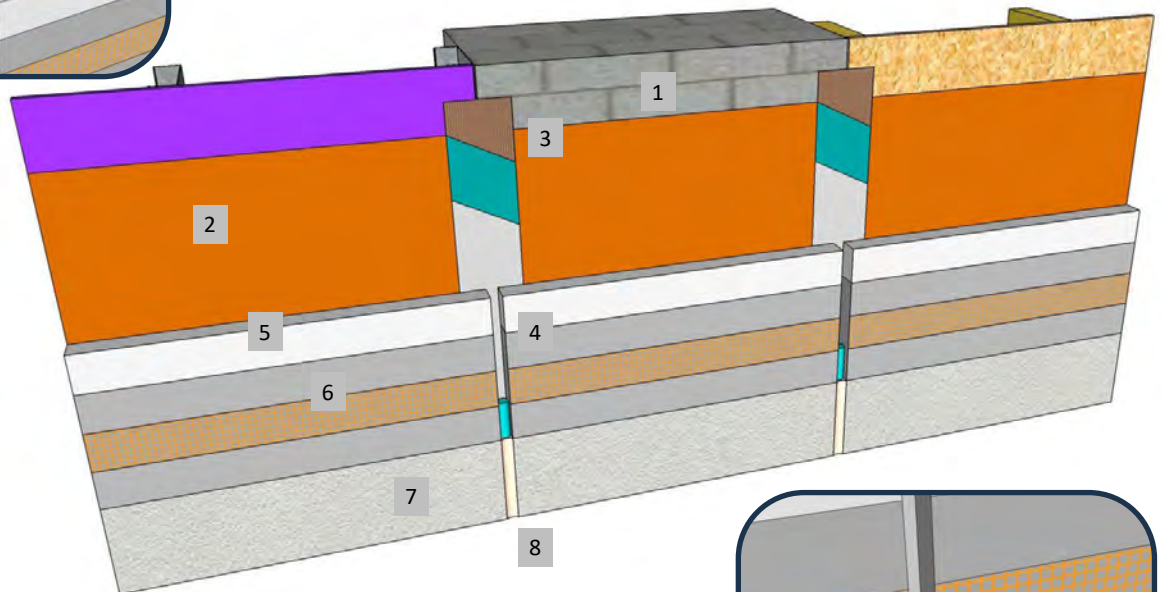
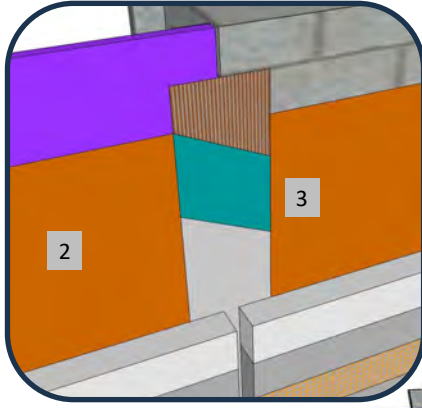

1. FRAMING & APPROVED SUBSTRATE
2. ROLLERSHIELD AIR/WATER BARRIER
3. MATERIAL BRIDGE: SUPERIORSHIELD FLASHING TAPE/SUPERIORFLASH WITH BACKING AS NEEDED OR WEATHERSTOP TAPE
4. BACKWRAPPED CIFS® SHOWN, EIFS PLASTIC ACCESSORIES ARE OPTIONAL
5. MASTER WALL INSULATION BOARD ADHERED WITH CHANNELED ADHESIVE
6. MASTER WALL BASE COAT AND MESH
7. SUPERIOR FINISH
8. SEALANT JOINT SIZED FOR ANTICIPATED MOVEMENT, 3/4" (19 MM) MIN.

RDCIFS-32 DISSIMILAR SUBSTRATES/SUBSTRATE CHANGE

M Master Wall Inc.
Building a Culture of Excellence

PO Box 397 · Fortson · GA · 31808 · 800-755-0825 · masterwall.com

These drawings relay the conceptual conditions of Master Wall® Systems and are not the construction drawings. Ultimately the design and detailing of an entire wall system is the responsibility of a professional. These details will guide the design professional in the use of Master Wall® Products. Master Wall disclaims design, warranty or construction intent or responsibility. Bold or Brand Name = Master Wall® Product. ©2024 Master Wall Inc.®



Master Wall Inc.®
Building a Culture of Excellence

**ROLLERSHIELD
DRAINAGE CIFS®**

SYSTEM DETAIL

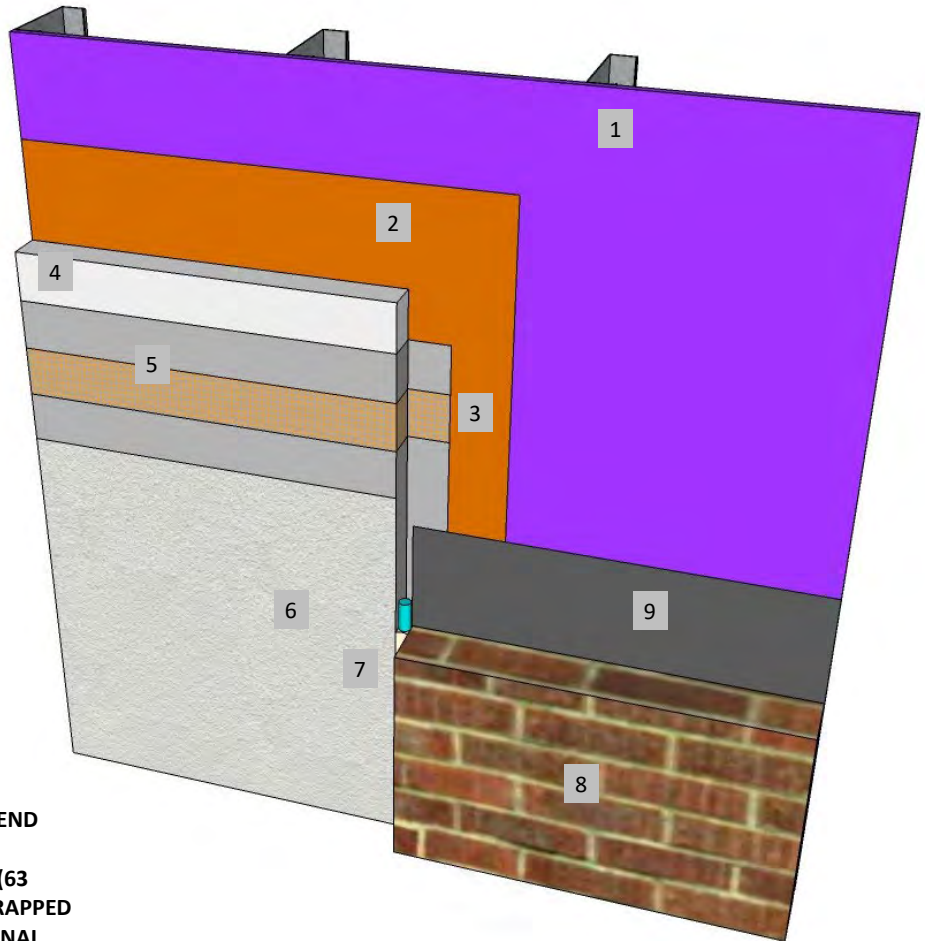
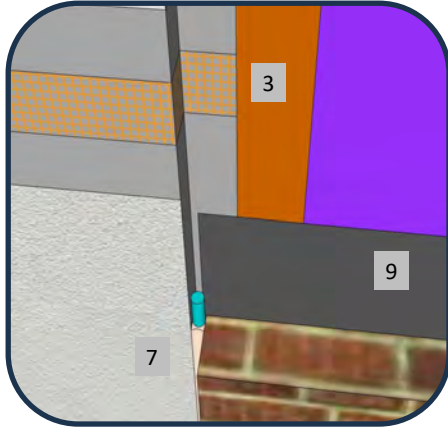

1. FRAMING & APPROVED SUBSTRATE
2. ROLLERSHIELD AIR/WATER BARRIER, EXTEND PAST SYSTEM IF POSSIBLE
3. BASE COAT AND MESH WRAPPED 2-1/2" (63 MM) MIN. ONTO WALL SHOWN, BACKWRAPPED OR EIFS PLASTIC ACCESSORIES ARE OPTIONAL
4. MASTER WALL INSULATION BOARD ADHERED WITH CHANNELED ADHESIVE
5. MASTER WALL BASE COAT AND MESH
6. SUPERIOR FINISH
7. SEALANT JOINT SIZED FOR ANTICIPATED MOVEMENT, 3/4" (19 MM) MIN.
8. DISSIMILAR MATERIAL (BRICK, STONE, SIDING, ETC.)
9. WEATHER RESISTIVE BARRIER

BEST PRACTICE: EXTEND ROLLERSHIELD 6" (15 CM) PAST TRANSITION LOCATION AND ENCAPSULATE WITH MESH AND BASE COAT EXTENDED 2-1/2" (63 MM) ONTO THE ROLLERSHIELD.

ALTERNATE PRACTICE: BACKWRAP EIFS, THEN SEAL THE OTHER MATERIAL WATER BARRIER TO THE CIFS® WITH AN APPROVED SEALANT (BY OTHERS)

RDCIFS-33 DISSIMILAR MATERIALS



Master Wall Inc.®
Building a Culture of Excellence

PO Box 397 · Fortson · GA · 31808 · 800-755-0825 · masterwall.com

These drawings relay the conceptual conditions of Master Wall® Systems and are not the construction drawings. Ultimately the design and detailing of an entire wall system is the responsibility of a professional. These details will guide the design professional in the use of Master Wall® Products. Master Wall disclaims design, warranty or construction intent or responsibility. Bold or Brand Name = Master Wall® Product. ©2024 Master Wall Inc.®



Master Wall Inc.
Building a Culture of Excellence

**ROLLERSHIELD
DRAINAGE CIFS®**

SYSTEM DETAIL

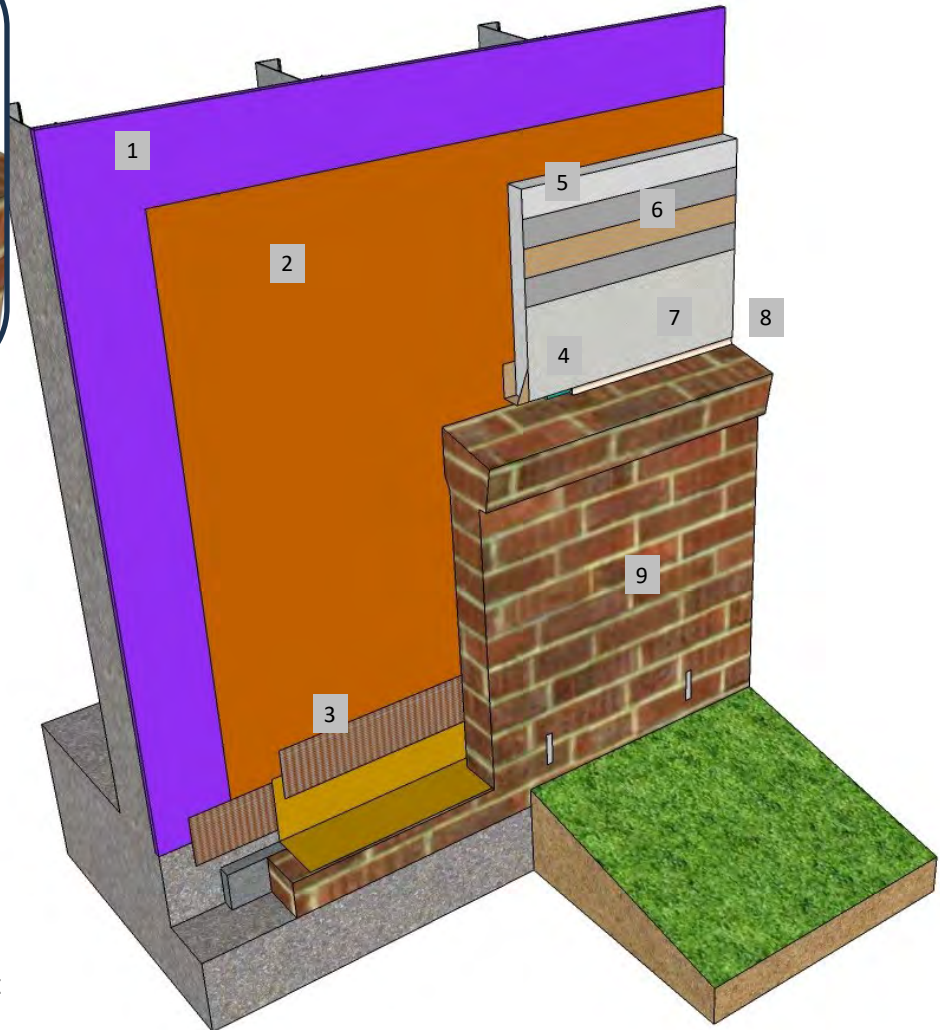
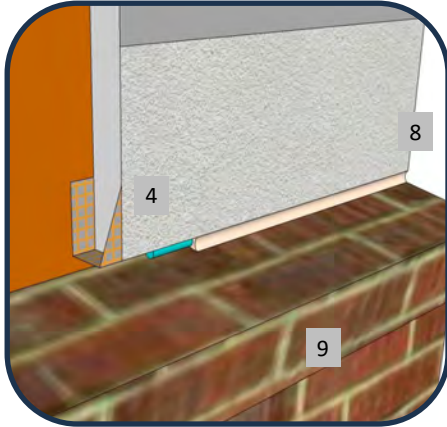

1. FRAMING & APPROVED SUBSTRATE
2. ROLLERSHIELD AIR/WATER BARRIER
3. SUPERIORSHIELD FLASHING TAPE FLASHED ONTO FLASHING
4. BACKWRAPPING SHOWN, EIFS PLASTIC ACCESSORIES ARE OPTIONAL
5. MASTER WALL INSULATION BOARD ADHERED WITH CHANNELED ADHESIVE
6. MASTER WALL BASE COAT AND MESH
7. SUPERIOR FINISH
8. SEALANT JOINT SIZED FOR ANTICIPATED MOVEMENT, 3/4" (19 MM) MIN.
9. DISSIMILAR MATERIAL (BRICK, STONE, SIDING, ETC.)

RDCIFS-34 DISSIMILAR CLADDING TRANSITION WITH CONTINUOUS WATER BARRIER

M Master Wall Inc.
Building a Culture of Excellence

PO Box 397 · Fortson · GA · 31808 · 800-755-0825 · masterwall.com

These drawings relay the conceptual conditions of Master Wall® Systems and are not the construction drawings. Ultimately the design and detailing of an entire wall system is the responsibility of a professional. These details will guide the design professional in the use of Master Wall® Products. Master Wall disclaims design, warranty or construction intent or responsibility. Bold or Brand Name = Master Wall® Product. ©2024 Master Wall Inc.®



Master Wall Inc.
Building a Culture of Excellence

**ROLLERSHIELD
DRAINAGE CIFS®**

SYSTEM DETAIL

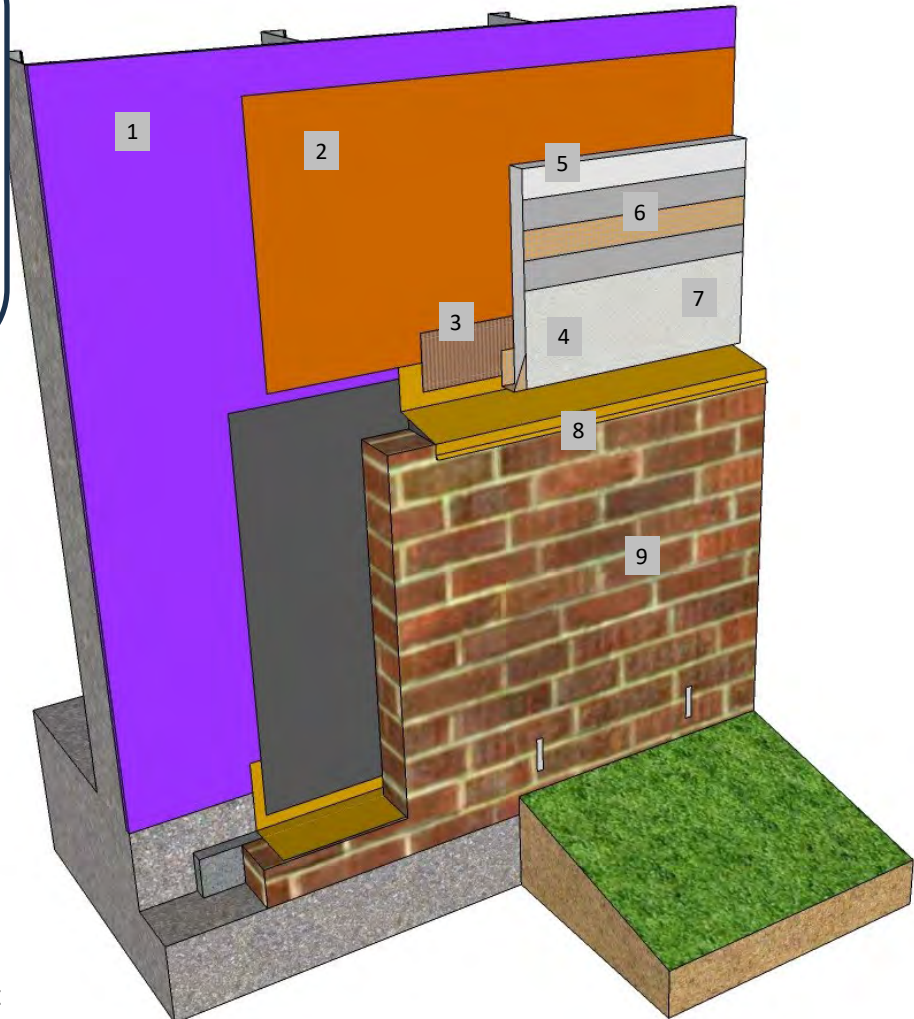
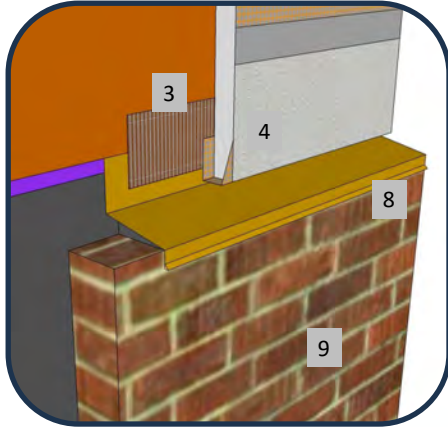

1. FRAMING & APPROVED SUBSTRATE
2. ROLLERSHIELD AIR/WATER BARRIER
3. SUPERIORSHIELD FLASHING TAPE FLASHED ONTO FLASHING
4. BACKWRAPPING SHOWN, DV ROLL & EIFS PLASTIC ACCESSORIES ARE OPTIONAL
5. MASTER WALL INSULATION BOARD ADHERED WITH CHANNELED ADHESIVE
6. MASTER WALL BASE COAT AND MESH
7. SUPERIOR FINISH
8. FLASHING, SLOPE TO DRAIN
9. DISSIMILAR MATERIAL (BRICK, STONE, SIDING, ETC.)

NOTE: LEAVE A 1/8" (3 MM) MINIMUM GAP TO ALLOW FOR DRAINAGE BETWEEN THE CIFS® AND FLASHING

RDCIFS-35 DISSIMILAR CLADDING TRANSITION WITH FLASHING

M Master Wall Inc.
Building a Culture of Excellence

PO Box 397 · Fortson · GA · 31808 · 800-755-0825 · masterwall.com

These drawings relay the conceptual conditions of Master Wall® Systems and are not the construction drawings. Ultimately the design and detailing of an entire wall system is the responsibility of a professional. These details will guide the design professional in the use of Master Wall® Products. Master Wall disclaims design, warranty or construction intent or responsibility. Bold or Brand Name = Master Wall® Product. ©2024 Master Wall Inc.®



Master Wall Inc.
Building a Culture of Excellence

**ROLLERSHIELD
DRAINAGE CIFS®**

SYSTEM DETAIL

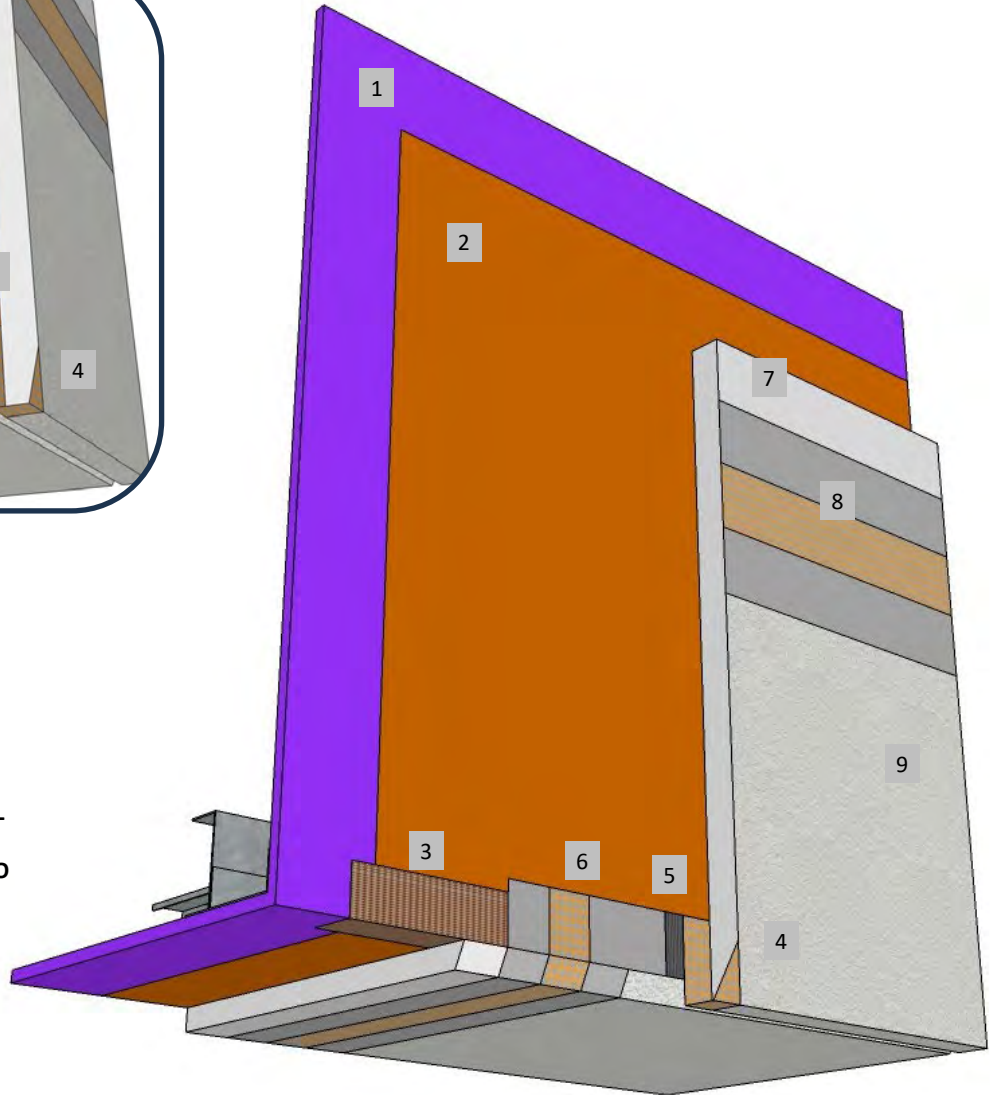
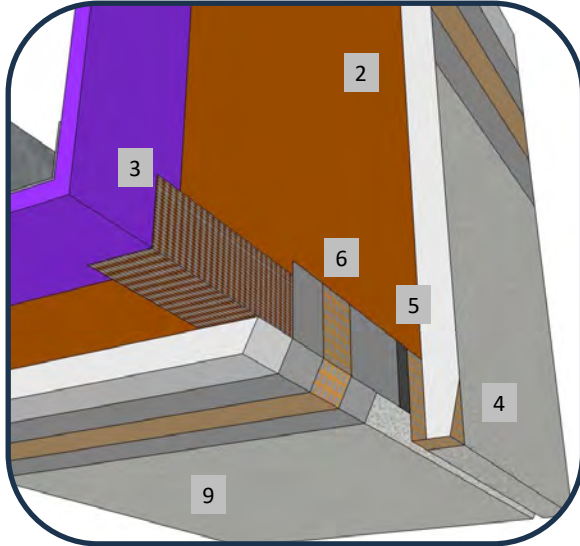

1. FRAMING & APPROVED SUBSTRATE
2. ROLLERSHIELD AIR/WATER BARRIER
3. SUPERIORSHIELD FLASHING TAPE
4. BACKWRAPPING SHOWN, EIFS
PLASTIC ACCESSORIES ARE OPTIONAL
5. DV ROLL, OPTIONAL
6. SOFFIT MESH SHOWN FLASHED ONTO
WALL 2-1/2" (63 MM) MIN.,
BACKWRAP OPTIONAL
7. MASTER WALL INSULATION BOARD
ADHERED WITH CHanneled
ADHESIVE
8. MASTER WALL BASE COAT AND
MESH
9. SUPERIOR FINISH

RDCIFS-36 SOFFIT/DRIP

M Master Wall Inc.
Building a Culture of Excellence

PO Box 397 · Fortson · GA · 31808 · 800-755-0825 · masterwall.com

These drawings relay the conceptual conditions of Master Wall® Systems and are not the construction drawings. Ultimately the design and detailing of an entire wall system is the responsibility of a professional. These details will guide the design professional in the use of Master Wall® Products. Master Wall disclaims design, warranty or construction intent or responsibility. Bold or Brand Name = Master Wall® Product. ©2024 Master Wall Inc.®



Master Wall Inc.
Building a Culture of Excellence

**ROLLERSHIELD
DRAINAGE CIFS®**

SYSTEM DETAIL

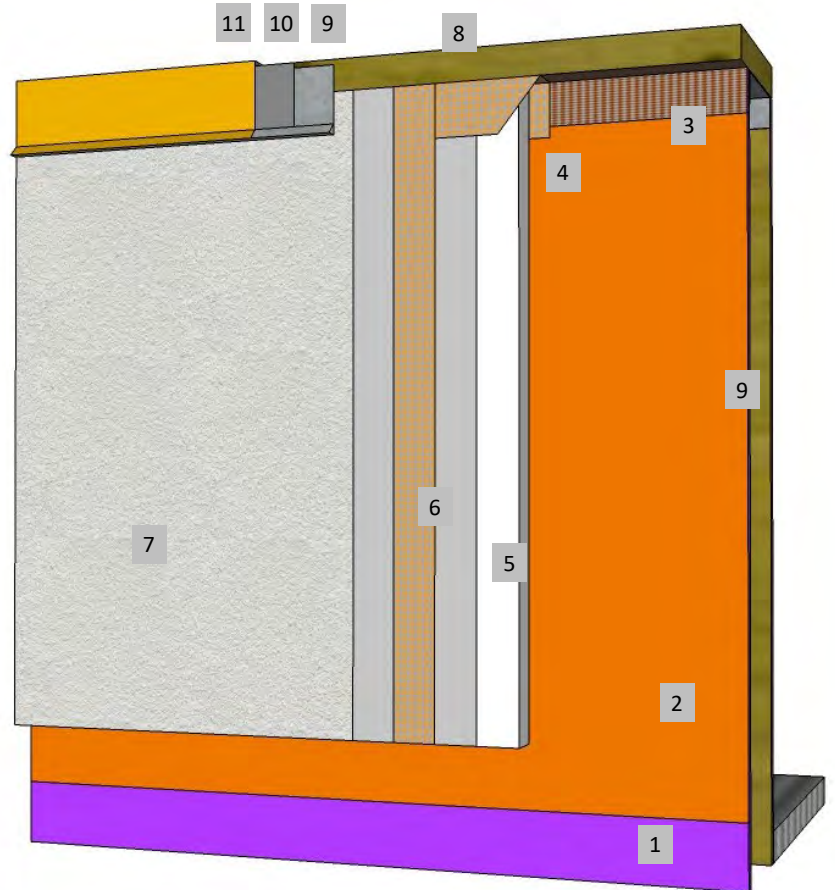
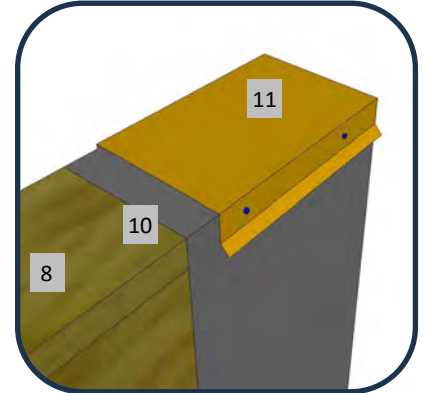
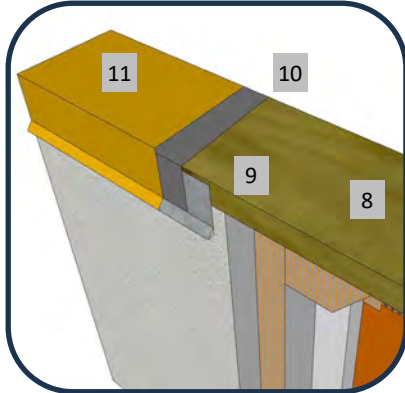

1. FRAMING & APPROVED SUBSTRATE
2. ROLLERSHIELD AIR/WATER BARRIER
3. SUPERIORSHIELD FLASHING TAPE PLACED ONTO NAILER
4. BACKWRAPPING SHOWN, EIFS PLASTIC ACCESSORIES ARE OPTIONAL
5. MASTER WALL INSULATION BOARD ADHERED WITH CHANNELED ADHESIVE
6. MASTER WALL BASE COAT AND MESH
7. SUPERIOR FINISH
8. TREATED NAILER
9. ROOF CLEAT, EXTEND 2-1/2" (63 MM) OVER SYSTEM AND SEAL LOWER EDGE
10. ROOFING MATERIAL OR SECONDARY UNDER-CAP PROTECTION
11. ROOF CAP, SLOPE TO BACK OF PARAPET, FASTENED TO NAILER

RDCIFS-37 PARAPET CAP

M Master Wall Inc.
Building a Culture of Excellence

PO Box 397 · Fortson · GA · 31808 · 800-755-0825 · masterwall.com

These drawings relay the conceptual conditions of Master Wall® Systems and are not the construction drawings. Ultimately the design and detailing of an entire wall system is the responsibility of a professional. These details will guide the design professional in the use of Master Wall® Products. Master Wall disclaims design, warranty or construction intent or responsibility. Bold or Brand Name = Master Wall® Product. ©2024 Master Wall Inc.®



Master Wall Inc.
Building a Culture of Excellence

**ROLLERSHIELD
DRAINAGE CIFS®**

SYSTEM DETAIL

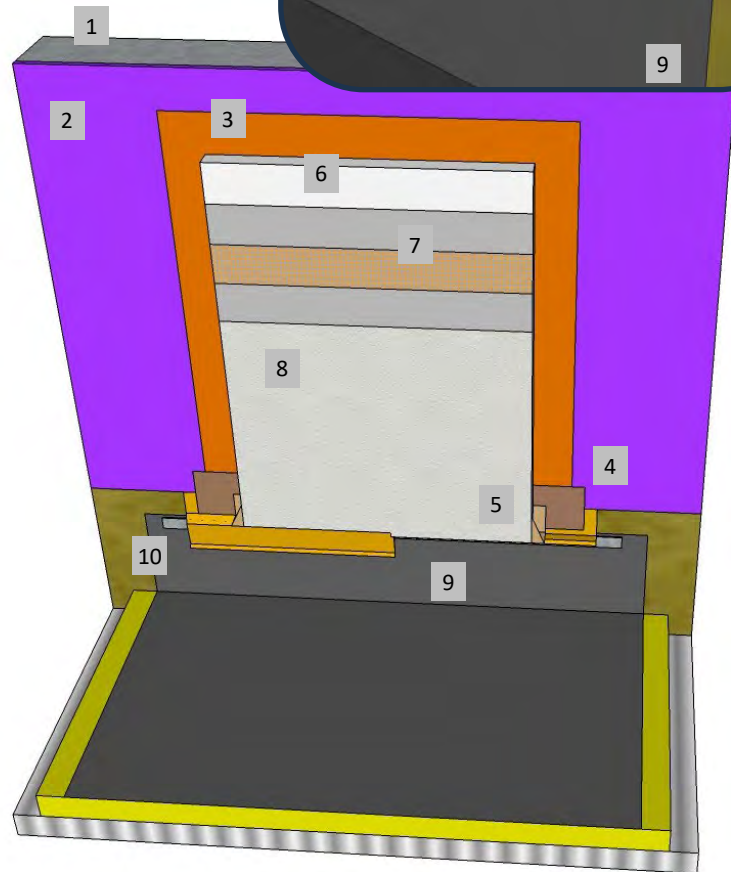
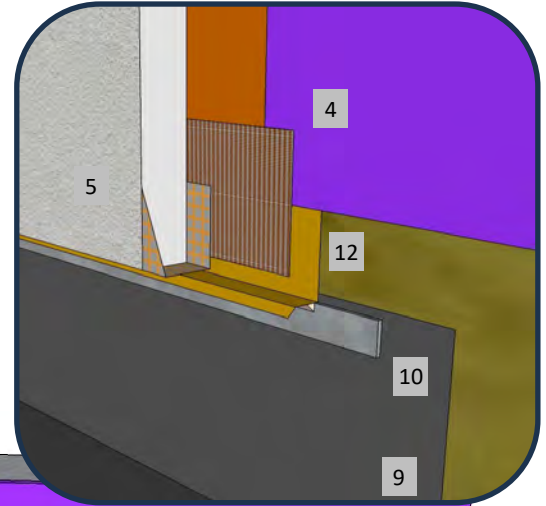
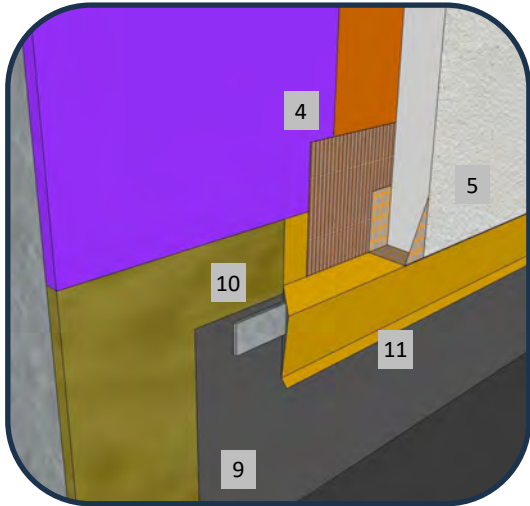

1. FRAMING
2. APPROVED SUBSTRATE
3. ROLLERSHIELD AIR/WATER BARRIER
4. SUPERIORSHIELD FLASHING TAPE WRAPPED ONTO FLASHING
5. BACKWRAPPED CIFS® SHOWN, DV ROLL OR DRAINAGE TRACK IS OPTIONAL
6. MASTER WALL INSULATION BOARD ADHERED WITH CHANNELED ADHESIVE
7. MASTER WALL BASE COAT AND MESH
8. SUPERIOR FINISH
9. KEEP SYSTEM 8" (203 MM) MIN. ABOVE ROOF PER ROOFING SYSTEM MANUFACTURER RECOMMENDATIONS
10. TERMINATION BAR OR OTHER TERMINATION PER ROOFING SYSTEM MANUFACTURER RECOMMENDATIONS
11. TWO-PIECE TYPE ROOF FLASHING TERMINATION, LEAVE OPEN FOR DRAINAGE
12. FLASHING TERMINATION, SEAL TO TERMINATION BAR, LEAVE APPROX. 1/8" (3 MM) GAP FOR DRAINAGE

RDCIFS-38 FLAT ROOF TERMINATION

M Master Wall Inc.
Building a Culture of Excellence

PO Box 397 · Fortson · GA · 31808 · 800-755-0825 · masterwall.com

These drawings relay the conceptual conditions of Master Wall® Systems and are not the construction drawings. Ultimately the design and detailing of an entire wall system is the responsibility of a professional. These details will guide the design professional in the use of Master Wall® Products. Master Wall disclaims design, warranty or construction intent or responsibility. Bold or Brand Name = Master Wall® Product. ©2024 Master Wall Inc.®



Master Wall Inc.
Building a Culture of Excellence

**ROLLERSHIELD
DRAINAGE CIFS®**

SYSTEM DETAIL

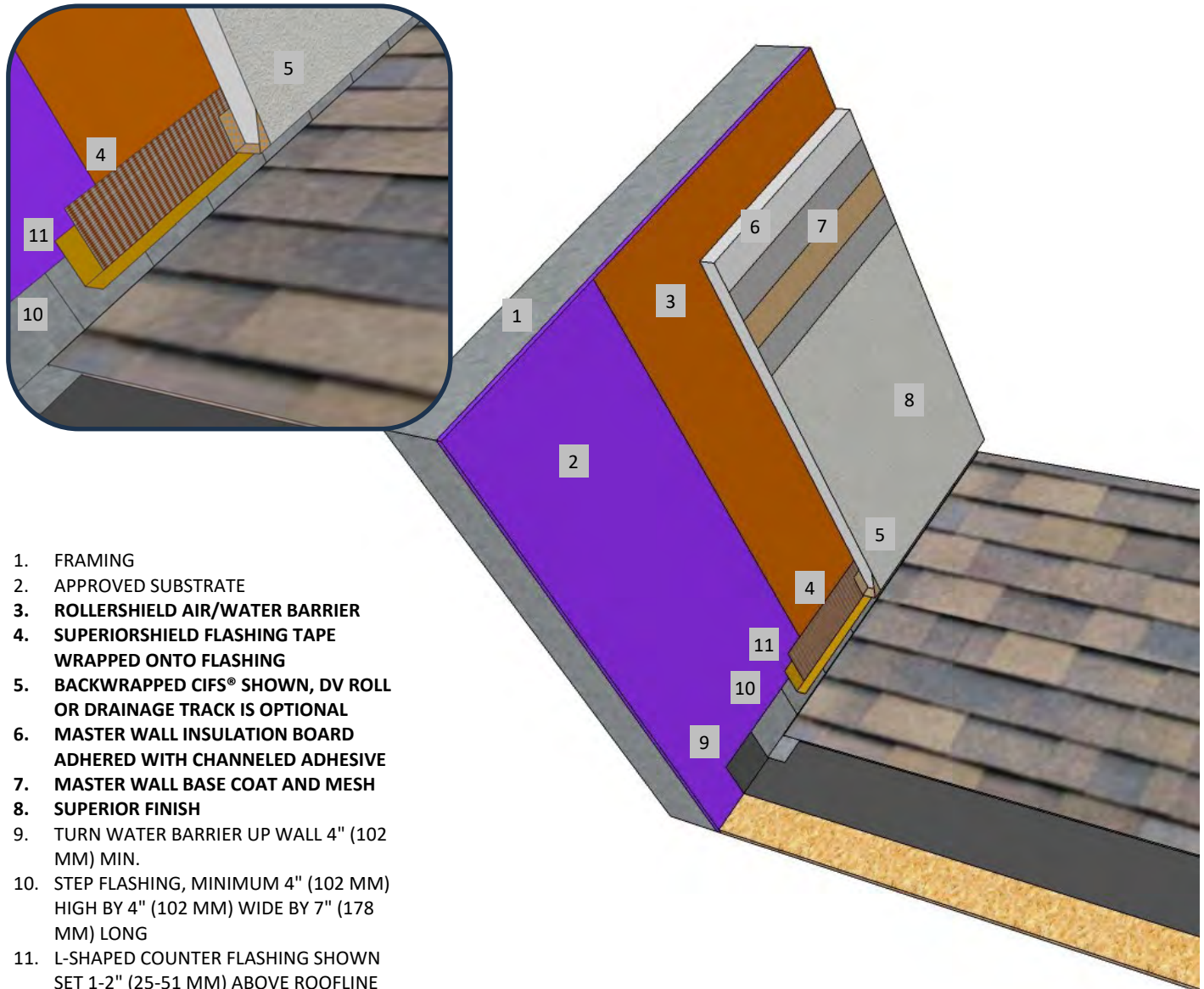

1. FRAMING
2. APPROVED SUBSTRATE
3. ROLLERSHIELD AIR/WATER BARRIER
4. SUPERIORSHIELD FLASHING TAPE WRAPPED ONTO FLASHING
5. BACKWRAPPED CIFS® SHOWN, DV ROLL OR DRAINAGE TRACK IS OPTIONAL
6. MASTER WALL INSULATION BOARD ADHERED WITH CHANNELED ADHESIVE
7. MASTER WALL BASE COAT AND MESH
8. SUPERIOR FINISH
9. TURN WATER BARRIER UP WALL 4" (102 MM) MIN.
10. STEP FLASHING, MINIMUM 4" (102 MM) HIGH BY 4" (102 MM) WIDE BY 7" (178 MM) LONG
11. L-SHAPED COUNTER FLASHING SHOWN SET 1-2" (25-51 MM) ABOVE ROOFLINE PER REGIONAL, NATIONAL OR BUILDING CODE REQUIREMENTS

RDCIFS-39 SLOPED ROOF TERMINATION

M Master Wall Inc.
Building a Culture of Excellence

PO Box 397 · Fortson · GA · 31808 · 800-755-0825 · masterwall.com

These drawings relay the conceptual conditions of Master Wall® Systems and are not the construction drawings. Ultimately the design and detailing of an entire wall system is the responsibility of a professional. These details will guide the design professional in the use of Master Wall® Products. Master Wall disclaims design, warranty or construction intent or responsibility. Bold or Brand Name = Master Wall® Product. ©2024 Master Wall Inc.®



Master Wall Inc.
Building a Culture of Excellence

**ROLLERSHIELD
DRAINAGE CIFS®**

SYSTEM DETAIL

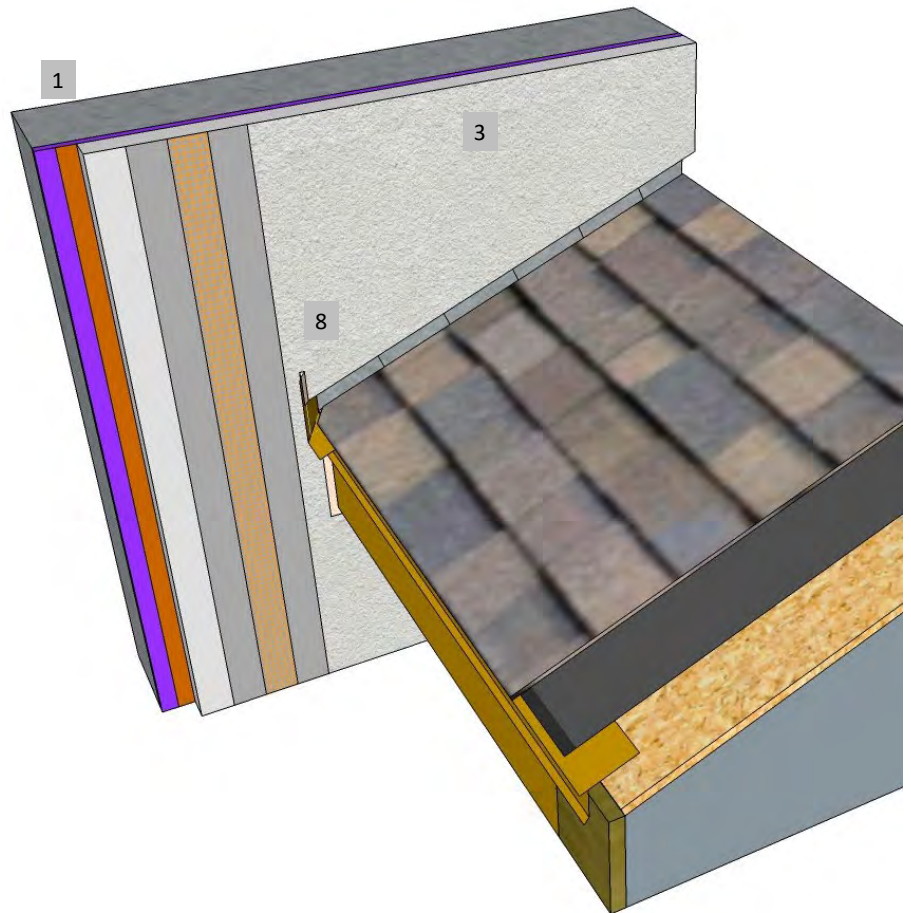
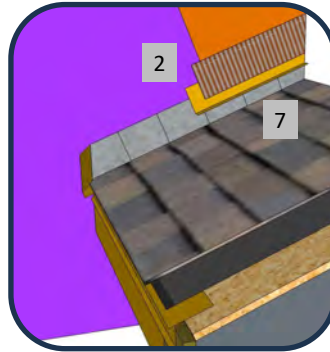
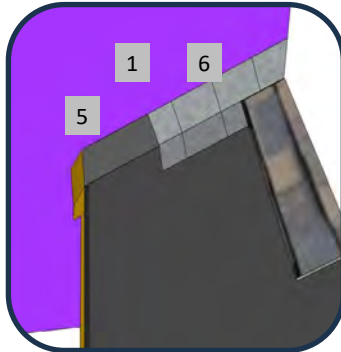
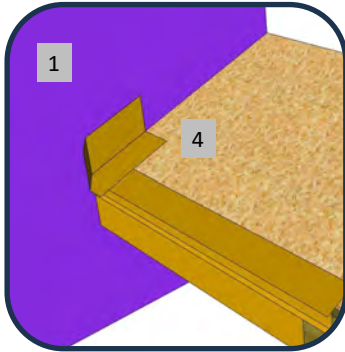

1. FRAMING & APPROVED SUBSTRATE
2. **ROLLERSHIELD AIR/WATER BARRIER – SEE SLOPED ROOF DETAIL**
3. **MASTER WALL ROLLERSHIELD DRAINAGE CIFS® APPLICATION**
4. PREFABRICATED ANGLED KICK OUT FLASHING, PREFERABLY SET IN SEALANT
5. TURN WATER BARRIER UP WALL 4" (102 MM) MIN.
6. STEP FLASHING, MINIMUM 4" (102 MM) HIGH BY 4" (102 MM) WIDE BY 7" (178 MM) LONG
7. L-SHAPED COUNTER FLASHING SHOWN SET 1-2" (25-51 MM) ABOVE ROOFLINE PER REGIONAL, NATIONAL OR BUILDING CODE REQUIREMENTS
8. SEAL KICK OUT FLASHING TO CIFS®

RDCIFS-40 KICK OUT FLASHING

M Master Wall Inc.
Building a Culture of Excellence

PO Box 397 · Fortson · GA · 31808 · 800-755-0825 · masterwall.com

These drawings relay the conceptual conditions of Master Wall® Systems and are not the construction drawings. Ultimately the design and detailing of an entire wall system is the responsibility of a professional. These details will guide the design professional in the use of Master Wall® Products. Master Wall disclaims design, warranty or construction intent or responsibility. Bold or Brand Name = Master Wall® Product. ©2024 Master Wall Inc.®



Master Wall Inc.
Building a Culture of Excellence

**ROLLERSHIELD
DRAINAGE CIFS®**

SYSTEM DETAIL

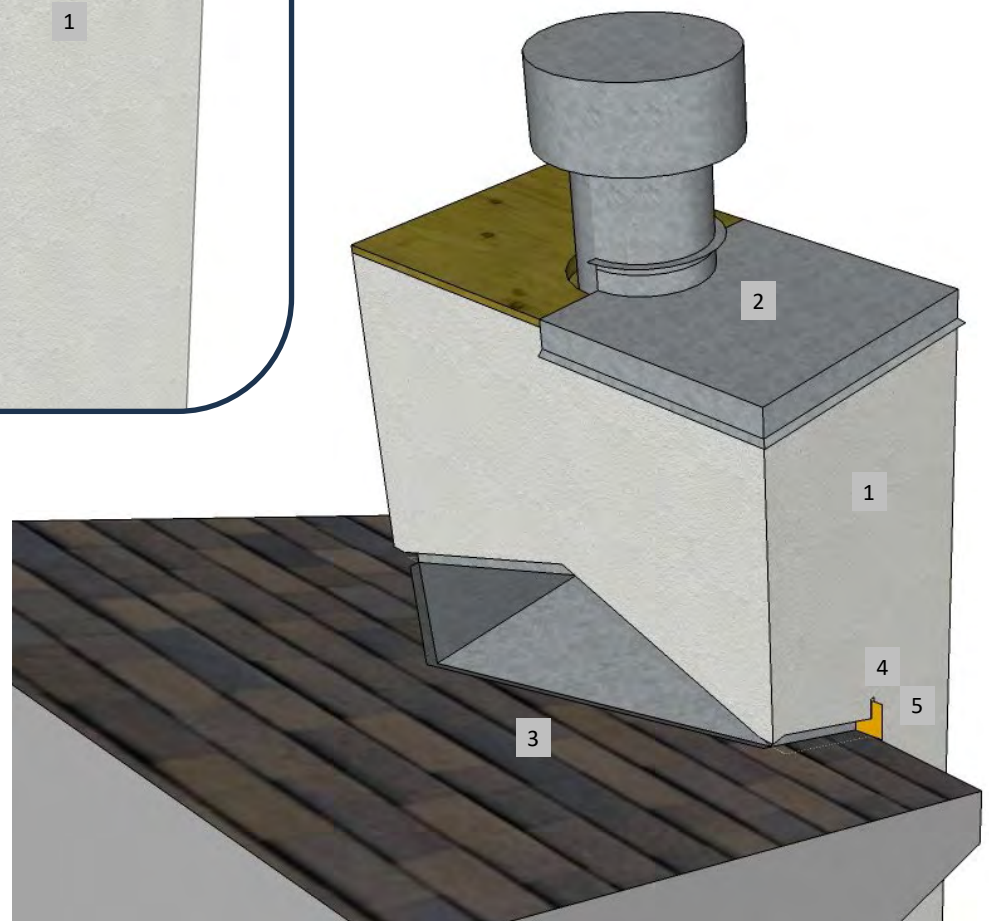

1. MASTER WALL ROLLERSHIELD DRAINAGE CIFS® APPLICATION
2. CHIMNEY CAP, EXTEND 2" (51 MM) MIN. OVER CIFS® AND SEAL LOWER EDGE.
3. CHIMNEY CRICKET FORMED OUT OF METAL OR ROOFING BY ROOFER, TURNED UP WALL 4" (102 MM) MIN.
4. ROOF KICK OUT
5. SEAL KICK OUT FLASHING TO CIFS®

RDCIFS-41 CHIMNEY CRICKET

M Master Wall Inc.
Building a Culture of Excellence

PO Box 397 · Fortson · GA · 31808 · 800-755-0825 · masterwall.com

These drawings relay the conceptual conditions of Master Wall® Systems and are not the construction drawings. Ultimately the design and detailing of an entire wall system is the responsibility of a professional. These details will guide the design professional in the use of Master Wall® Products. Master Wall disclaims design, warranty or construction intent or responsibility. Bold or Brand Name = Master Wall® Product. ©2024 Master Wall Inc.®