



# F&M Adhesive & Base Coat

## **Systems**

Aggre-flex EIFS  
Aggre-flex Drainage EIFS  
Cemplaster Fiberstucco  
ICF Coatings  
QRW1 Drainage EIFS  
Rollershield Drainage CIFS®  
Soffit System  
Stucco Cement Board Coatings  
Uninsulated Finishes

**VOC: <1% by Weight**  
**VOC: 0.9 g/l**  
**Manufacture Locations:**  
**30058 • 77474 • 84651**

**Packaging: 5 gallon (19L)  
pail**

**Pail Weight: 60 lbs (27 kg)**

**Shelf Life: 2 years**

**Coverage (estimated)**  
**Adhesive & Standard Base  
Coat: 120 sf (11 sm)**

**Embedding Single-layer of  
Mesh: 240-280 sf (22-26 sm)**

**Double Layer of Mesh: 80-230  
sf (7.5-21 sm)**

**Notched Trowel Adhesive  
Application: 135 sf (12.5 sm)**

**Foam & Mesh  
Adhesive (F&M) is  
a 100% acrylic  
formulated high  
performance base  
coat and adhesive**



**used in Master Wall® Systems or over  
prepared substrates including brick,  
masonry, concrete and stucco.**

- **Adheres insulation board to approved substrates**
- **Excellent water resistance**
- **Mixes 1:1 with Portland cement to a creamy consistency**
- **Base coat for Aggre-flex Mesh**

## **Product Test Standards**

ASTM C67, ASTM C297, ASTM D897, ASTM D2247, ASTM E2489/EIMA 101.86, ASTM D5420, ASTM E96, ASTM E330, ASTM E331, ASTM E2273, ASTM E2485, ASTM E84, IBC 1403, NFPA 268

 **Master Wall Inc.®**  
*Building a Culture of Excellence*  
**masterwall.com**

**PO Box 397 • Fortson • GA • 31808 • 800-755-0825 • Tech: 800-760-2861**



# F&M Adhesive & Base Coat

**Temp: 40°-110°F (5°-43°C) • Working Time: 1 hr • Dry Time: 12 hrs**  
at room temperature, working and drying time will vary with temperature and humidity

## Application Procedure

**Job Conditions** - Air and substrate temperature for application of F&M must be 40°F (5°C) or higher and must remain 40°F (5°C) or higher for a minimum of 24 hours. Provide temporary protection to protect the wall system from damage until permanent flashings, caps and sealants are installed. Store materials within prescribed temperature limits and out of direct sunlight. Working and drying times are based upon normal room temperature conditions and will vary with temperature and humidity.

**Preparation** - The substrate must be approved by Master Wall Inc.®, clean, dry, structurally sound and free of efflorescence, oil, grease, form release agents and curing compounds or anything that would affect bond. Painted surfaces are not acceptable and must be removed.

**Mixing** - Thoroughly stir F&M using a heavy duty 1/2" (12.7 mm) drill at 400 - 500 rpm and a heavy duty mixing paddle. Pour half of the stirred F&M into a clean plastic pail. Add Type I or I-II Portland cement to the half pail of F&M in a ratio of one-to-one by weight and mix to a homogenous consistency. Let the mixture stand for 3 to 5 minutes and then stir to a creamy consistency. Up to 30 ounces (0.9L) of clean, potable water may be added to a half pail to adjust workability. Do not over mix as faster setting or reduced working time can occur. Do not add accelerators or retarders to the F&M mixture.

### Application

**Adhesive application** – Over gypsum substrates, apply the F&M mixture directly to the back of the insulation board using a 3/8"x3/8"x3/8" (9.5x9.5x9.5 mm) or a 3/8"x1/2"x1-1/2" (9.5x13x38 mm) stainless steel notched trowel. With the trowel at a 45° angle, cover the entire back of the insulation board with full beads of adhesive. Apply the adhesive so the ribbons run vertically when applied to the wall.

Over non-gypsum substrates, you may use the above described notched trowel method or the 'ribbon and dab' method. Using a stainless steel plastering trowel, apply a 2" (50.8 mm) wide by 3/8" (9.5 mm) high ribbon of the F&M mixture around the entire perimeter of the insulation board. Place 8 dabs of the F&M mixture 3/8" (9.5 mm) thick by 4" (102 mm) in diameter approximately 8" (204 mm) on center inside the ribbon.

Immediately place the prepared insulation board on the substrate. Make sure that all edges of the insulation board are abutted tightly and that no F&M mixture gets into the board joints. Do not allow the F&M mixture to form a skin prior to placing the insulation board on the substrate. Do not apply the F&M mixture directly onto the substrate.

**For base coat application** – All imperfections in the insulation board must be rasped flush and any gaps in the insulation board must be filled with slivers of insulation. Apply the F&M mixture over the entire surface of the insulation board in a thickness greater than that of the reinforcing fabric being used (approximately 1/16" (1.6 mm) for standard mesh and 3/32" (2.4 mm) for Ultra Mesh). Immediately embed the reinforcing fabric into the wet F&M mixture and smooth from the center to the edge to avoid wrinkles. The reinforcing fabric must be continuous at all corners and lapped or abutted in accordance to Master Wall® specifications. The color of the mesh shall not be visible but a slight mesh pattern may be visible.

**Clean Up**—Tools and equipment can be cleaned with soapy water while the F&M is still wet.

### WARNING, THIS PRODUCT CONTAINS SILICA

If sanding or scraping are performed, ventilate work area and/or use a NIOSH/MSHA-approved respirator in accordance with our Safety Data Sheet.

### Approved Substrates

Exterior gypsum sheathing (ASTM C1396, C1177)

Dens Glass Gold®

GlasRoc®

FiberBond®

Gold Bond e2xp®

Securock®

Weather Defense Platinum™

Durock®

PermaBase®

Util-A-Crete®

ProTEC®, ProGUARD®

Concrete

Brick

Masonry

Metal Lath

Adheres to Rollershield

Others approved in writing

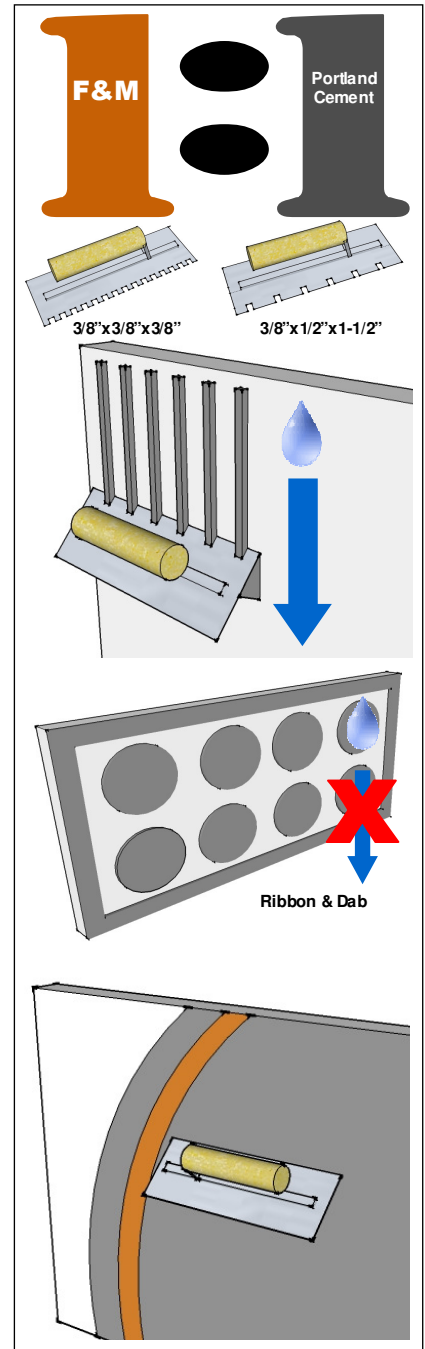

Information contained in this product data sheet conforms to the standard detail recommendations and specifications for the installation of Master Wall Inc.® products and is presented in good faith. Master Wall Inc.® assumes no liability, expressed or implied as to the architecture, engineering, or workmanship of any project. This information may be concurrent with, or superseded by other applicable documents, such as specifications and details. Contact Master Wall Inc.® for the most current product information. ©2018 Master Wall Inc.®



PO Box 397 • Fortson • GA • 31808 • 800-755-0825 • Tech: 800-760-2861