

Project Submittal Package



Project:

Location:

Architect:

General Contractor:

Applicator:



Master Wall Inc.®



[System Data Sheets](#) [Product Data Sheets](#) [Sample Warranty](#)

[Specifications](#) [Details](#) [Web Link \(click here\)](#)

PO Box 397

Fortson

GA

31808

800-755-0825

masterwall.com



Master Wall Inc.®
Building a Culture of Excellence

**LiMa i610CB LIGHT MASONRY
WALL SYSTEM**

The LiMa i610CB thin brick and stone system is an insulated cement board featuring Hunter Polyisocyanurate Insulation boards and National Gypsum PermaBase® Cement Board.

It features our Rollershield air and water barrier product that is either rolled, sprayed or troweled in place. With any method, the product offers excellent water holdout capabilities compared to a sheet good and has class-leading air sealing capability.

The UltraBond adhesive has class leading slump resistance and cures quickly to quickly get your wall system in service.

Features & Benefits

- 10-year limited warranty
- Extremely low air infiltration properties
- Rollershield seals around nail holes
- Rollershield options
 - Rollershield-RS, vapor open roll grade
 - Rollershield-TG, vapor open trowel grade
 - Rollershield-VB vapor closed roll grade
- Simplified construction
- R-10 insulation value
- Quality products with great durability

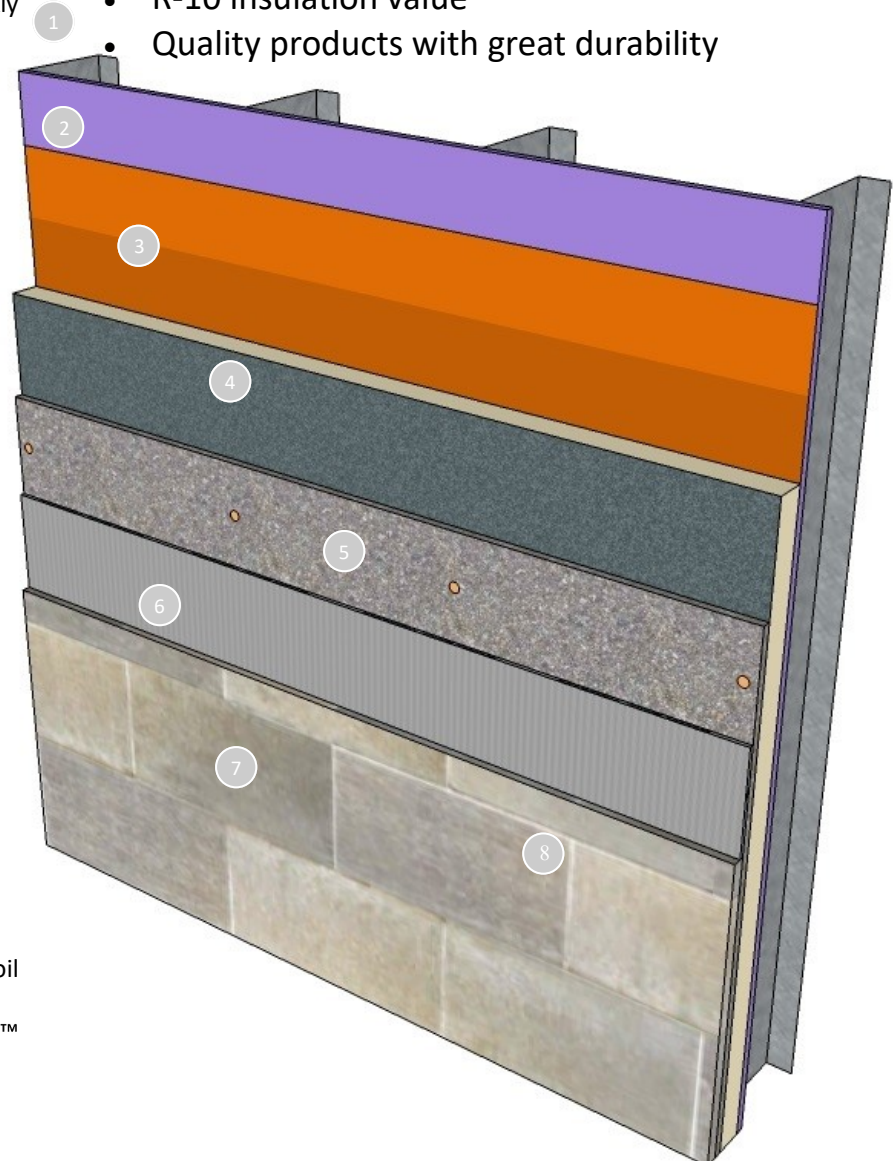

1. Wood or Metal Framing
2. Approved Substrate
3. Rollershield
(2 coats or 22 mils dry thickness)
4. Hunter Xci-CG or CG (Class A) or Xci-Foil
(Class A)
5. PermaBase® CI Insulated Cement Board™
with recommended fasteners
6. UltraBond Adhesive
7. Thin Brick or Stone (by others)
8. Mortar (by others)

Short Form Specification

1.0 General

This is a specification for the application of a Master Wall® Light Masonry (LiMa) application over wood or metal framing and sheathing with polyisocyanurate insulation and cement board.

1.1 System Description

The Master Wall® LiMa i610CB is a light masonry stone or thin brick application over polyisocyanurate insulation and cement board. It uses two coats of SuperiorShield Rollershield as the air and water barrier under the cement board with UltraBond as the adhesive for ICC-ES AC51 compliant stone or thin brick with CIFS® Brick Mortar.

1.2 Design Requirements:

- A. Reference Master Wall® suggested details and architectural drawings for specific detail requirements.
- B. Slope all surfaces a minimum of 1:2 (6" in 12") to shed water, maximum 12" (305 mm) wide.
- C. Maximum deflection of substrates shall not exceed L/360.
- D. Typical acceptable substrates include CDX exterior grade plywood, Exposure 1 Oriented Strand Board (OSB), ASTM C1177 exterior gypsum sheathing, concrete, masonry or other approved substrates noted on the Rollershield-RS data sheet.
- E. Expansion joints are required in the cladding at building expansion joints, panel joints, floor lines in wood framed construction, and other areas where significant movement occurs.

1.3 Quality Assurance

- A. The Rollershield air/water barrier shall be recognized in IAPMO ER-0384.
- B. SuperiorShield product bulletins, application instructions and details.
- C. National Gypsum PermaBase® installation instructions and code report.

1.4 Job Conditions

- A. Store all materials protected from weather and direct sunlight at temperatures above 40°F (5°C).
- B. The ambient and wall temperature shall be a minimum of 40°F (5°C) and shall remain so for at least 24 hours after installation.

1.5 Warranty

- A. Application shall include a 10-year limited warranty, please reference the LiMa Warranty Program Limited Warranty.

2.0 Products

All components of the LiMa application shall be manufactured by Master Wall® and supplied by an authorized distributor.

2.1 SuperiorShield Water Barrier & Flashing Tapes:

- A. SuperiorShield Rollershield RS: A 100% pure acrylic-based roll-applied weather-resistive barrier.
- B. SuperiorShield Rollershield TG: A 100% pure acrylic-based trowel grade water-resistive barrier.
- C. SuperiorShield Rollershield VB: Acrylic-based vapor barrier water resistive barrier.
- D. SuperiorShield Flashing Tape: A lightweight nonwoven joint treatment material.
- E. SuperiorShield Mesh Tape: A lightweight joint treatment material.
- F. SuperiorFlash: A single-component fluid applied flashing.

2.2 Polyisocyanurate Insulation:

- A. Hunter Xci-CG or CG (Class A), maximum 1" (25 mm) thick.
- B. Hunter Xci-Foil (Class A), maximum 1" (25 mm) thick.

2.3 Cement Board: National Gypsum PermaBase® in 1/2" (12.7 mm) or 5/8" (15.9 mm) thickness along with recommended fasteners.

2.4 Master Wall® Stone/Thin Brick Adhesive: UltraBond, A ready to use dry base adhesive that is field mixed with water.

3.0 Installation

- 3.1 Inspect the substrate to ensure that it is free of all foreign materials that would affect the adhesion of the Rollershield air and water barrier.
- 3.2 Apply the Rollershield products in accordance with the product data sheets, minimum two coats or a single coating with a dry mil thickness of at least 22 mils.
- 3.3 Tack-attach insulation board panels to the framing using Wind-Lock™ climate treated fasteners with Lath Lock plates or approved equal. Size fasteners for insulation and sheathing thickness and of type appropriate for the material being fastened to.
- 3.4 Attach cement board to framing members using approved fasteners at a minimum of 8" (20 cm) centers.
- 3.5 Adhere ICC-ES AC51-compliant stone or thin brick using UltraBond, mixed following data sheet instructions. Allow to cure before proceeding with mortar application.
- 3.6 Mortar with recommended mortar, mixed with water following data sheet instructions. Place in joints using a grout bag or similar device and rake/tool when thumb print hard.
- 3.7 Allow the wall system to cure and protect from weather for at least 72 hours before placing in service.

Information contained in this product data sheet conforms to the standard detail recommendations and specifications for the installation of Master Wall Inc.® products and is presented in good faith. Master Wall Inc.® assumes no liability, expressed or implied as to the architecture, engineering, or workmanship of any project. This information may be concurrent with, or superseded by other applicable documents, such as specifications and details. Contact Master Wall Inc.® for the most current product information. ©2025 Master Wall Inc.®



PRODUCT AND SYSTEM TESTING



Master Wall Inc.
Building a Culture of Excellence



MASTER WALL® SYSTEMS SPECIFICATION FACT SHEET

- Manufacturer of EIFS, Stucco and Coatings since 1987
- Committed and focused specifically on our industry; privately held and American owned.
- Pioneer in CIFS® (Continuous Insulation and Finish Systems)
- Leader in specialty finishes; CIFS® Wood Grain, CIFS® Brick, Hydrophobic Finishes, Metallics, SuperiorCote coatings
- AWCI Certified EIFS Professional (CEP) accredited Sales and Technical Force
- AIA MasterSpec listed, AIA CES Registered Provider
- Industry Leadership
 - EIMA (EIFS Industry Members Association) – Manufacturer Member and Current President
 - NOCSA (National One Coat Stucco Association) – Manufacturer Member and Current President
 - SMA (Stucco Manufacturer's Association) – Manufacturer Member and Board Member
 - ABAA (Air Barrier Association of America) – Manufacturer Member
 - AWCI (Association of the Wall and Ceiling Industry) – Member
 - FWCCA (Florida Wall & Ceiling Contractors Association) – Member
- Code Compliant EIFS, CIFS® Stucco and Air Barrier Systems (ICC, Miami Dade and Florida Building Code recognized systems)
- Full-service product support including sales and technical aspects of your project
- Labor and Material Limited Warranties exceeding other manufacturers ranging up to 20 years including Single-source envelope warranties with approved Sealant manufacturers.
- DuroTone High Performance Tint Pigments for Improved Color Retention (5-year fade warranty)
- Manufacturing strategically located in Stonecrest GA, Brookshire TX and Payson UT
- Nationwide distributor network that serves most major markets



Master Wall Inc. continuously tests our products and systems to meet the most current building codes.

FIRE TESTING			
Test	Test Method	Criteria	Results
Fire Resistance	ASTM E119	No effect on the fire resistance of a rated wall assembly	See Technical Bulletin MW#168-030111 for assemblies
Ignitability	NFPA 268 (BOCA 99/1407.0)	No ignition at 12.5 kw/m ² at 20 minutes	Pass
Intermediate Multi-Story Fire Test	NFPA 285 (UBC 26-9)	<ol style="list-style-type: none"> 1. Resist flame propagation over the exterior surface 2. Resist vertical spread of flame within combustible core/component of panel from one story to the next 3. Resist vertical spread of flame over the interior surface from one story to the next 4. Resist lateral spread of flame from the compartment of fire origin to adjacent spaces 	Pass
Surface Burning Characteristics— Base Coat, Mesh and Finish	ASTM E84	All components shall have a: Flame Spread < 25 Smoke Developed < 450	Flame Spread = 0 Smoke Developed = 0
Surface Burning Characteristics— Rollershield	ASTM E84	All components shall have a: Flame Spread < 25 Smoke Developed < 450	Flame Spread = 5 Smoke Developed = 5
Heat and Smoke Release Rates for Rollershield Air/ Water Barrier	ASTM E1354, IBC Section 1403.5, Exception 2 Requirements	Peak Heat Release Rate <150 kWm ² Total Heat Release Rate <20 MJ/m ² , Effective Heat of Combustion <18 MJ/kg	RS: Peak Heat Release Rate = 32 kWm ² , Total Heat Release Rate = 3.6 MJ/m ² , Effective Heat of Combustion = 2.5 MJ/kg, VB: Peak Heat Release Rate = 336 kWm ² , Total Heat Release Rate = 8.8 MJ/m ² , Effective Heat of Combustion = 9.3 MJ/kg

MESHES AND INSULATION BOARD			
Test	Test Method	Criteria	Results
Reinforcing Mesh Alkali Resistance of Reinforcing Mesh	ASTM E2098 (formerly EIMA 105.01)	>21dN/cm (120 pli) retained tensile strength after exposure	Pass
EPS (Physical Properties)			
Density	ASTM C303, D1622	15.2-20.0 kg/m ³ (0.95-1.25 lb/ft ³)	Pass
Thermal Resistance	ASTM C177, C518	4.0 @ 4.4 °C (40 °F)	Pass
Water Absorption	ASTM C272	3.6 @ 23.9 °C (75 °F)	
Oxygen Index	ASTM D2863	2.5 % max. by volume	Pass
Compressive Strength	ASTM D1621 Proc. A	24% min. by volume	Pass
Flexural Strength	ASTM C203	69 kPa (10 psi) min.	Pass
Flame Spread	ASTM E84	172 kPa (25 psi) min.	Pass
Smoke Developed		25 max. 450 max.	Pass Pass



EIFS & COATING

Test	Test Method	Criteria	Results
Abrasion Resistance	ASTM D968	No deleterious effects after 500 liters (528 quarts)	Pass
Accelerated Weathering	ASTM G155 Cycle 1	No deleterious effects after 2000 hours	Pass
Accelerated Weathering	ASTM G23 (G152 & 153)	No deleterious effects after 2000 hours	Pass
Accelerated Weathering	ASTM G53	No deleterious effects after 2000 hours (QUV)	Pass
Freeze-Thaw	ASTM E2485 (formerly EIMA 101.01)	No deleterious effects after 60 cycles	Pass
Freeze-Thaw	ASTM C67 modified/ICBO AC24	No deleterious effects after 10 cycles	Pass
Freeze-Thaw	ASTM E2485/ICC-ES Proc. ICC ES (AC 235)***	No deleterious effects after 10 cycles	Pass
Mildew Resistance	ASTM D3273	No growth during 28 day exposure period	Pass
Water Resistance	ASTM D2247	No deleterious effects after 14 days exposure	Pass
Impact	ASTM D5420	Gardner Impact Falling Weight	Pass
Salt Spray Resistance	ASTM B 117	No deleterious effects after 300 hours exposure	Pass
Water Penetration	ASTM E331 ICC ES (AC 235)***	No water penetration beyond the inner-most plane of the wall after 15 minutes at 137 Pa (2.86 psf)	Pass at 2.86 psf (137 Pa), 6.24 psf (299 Pa), and 12.0 psf (575 Pa) consecutively
Water Vapor Transmission	ASTM E 96 Water Method	Vapor permeable perm (ng/Pa.s.m ²)	EPS 5 perm-inch (114) Base Coat* 12 (679) Finish** 12 (674)
Component-Specific Weather Protection	IBC 1403	2-hour water test of EIFS and specific components	Pass
Drainage Efficiency	ASTM E 2273 ICC ES (AC 235)***	Minimum Drainage Efficiency of 90%	Aggre-flex Drainage 97.8% Rollershield Drainage 99.2% QRW1 Drainage 97.8%
* Base Coat perm value based on Master Wall F&M ** Finish perm value based on Master Wall Perfect Texture *** AC 235 (ASTM E 2568) – Acceptance Criteria for EIFS Clad Drainage Wall Assemblies			
Tensile Bond	ASTM C297/E2134	Minimum 15 psi (104 kPa) – substrate or insulation failure	Plywood/EPSA 67 psi (464) OSB/ EPSA 22 psi (152) Brick/F&M 105 psi (728) Concrete/F&M 94 psi (651) Gypsum/F&M 30 psi (208)
Tensile Bond	ASTM D897	Bond strength before and after 2000 hours florescent UV condensation weathering.	Before 24.6 psi After 22.7 psi
Transverse Wind Load	ASTM E330	Withstand positive and negative wind loads as specified by the building code	Pass. Assemblies vary from 68-287 psf*
* Ultimate wind loads – contact Master Wall for specific assemblies.			



IMPACT RESISTANCE (ASTM E2486/EIMA 101.86)

Description	OZ/SY	IN-LB Results	Joules	EIMA Classification
Standard Mesh	4.5	50-89	6-10	Medium
Hi-Tech Mesh	6.0	50-89	6-10	Medium
Medium Mesh	10.4	50-89	10-17	Medium
Medium & Standard Mesh	10.4 & 4.5	90-150	10-17	High Impact
Strong & Standard Mesh	15.0 & 4.5	Over 150	>17	Ultra High Impact
Ultra & Standard Mesh	21.0 & 4.5	Over 150	>17	Ultra High Impact

CEMPLASTER FIBERSTUCCO

Test	Test Method	Criteria	Results
Finishes & Coatings	Varies		Reference EIFS & Coatings Data
Freeze-Thaw	ICC AC11	No deleterious effects after 10 cycles	Pass
Transverse Load	ICC AC11/ASTM E330	Withstand positive and negative wind loads as specified by the building code	Pass. Assemblies vary from 81-124 psf*
Compressive Strength	ASTM C109	Average load for cured sample	1910 psi
Fire Resistance	ASTM E119	No effect on the fire resistance of a rated wall assembly	See Technical Bulletin MW#168-030111 for assemblies
Combustibility	ASTM E136	Standard Test Method for Assessing Combustibility of Materials in a Vertical Tube Furnace at 750°C, Option A	Pass
Accelerated Weathering	ASTM G26/G155	No deleterious effects after 2000 hours	Pass

* Ultimate wind loads – contact Master Wall for specific assemblies.



ROLLERSHIELD LAB (LIQUID APPLIED AIR/WATER BARRIER)

Test	Test Method	Criteria	Results
Solids Content	Calculation		Rollershield RS – 69.52% solids by weight (55.05% by volume), Rollershield TG – 73.85% solids by weight (60.12% by volume), Rollershield VB – 68.19% solids by weight (52.97% by volume)
Tensile Bond	ASTM C297/E2134 ICC ES (AC 212)*	Minimum 15 psi (104 kPa)	Dens Glass Gold 31 (215), Exterior Gypsum 28 (194), OSB 40 (277), Plywood 79 (563), Cement Board 70 (485), Copper 185 (1282), Galvanized steel 180 (1248), PVC 168 (1165), Aluminum 184 (1275), Coated Aluminum 203 (1407), Stainless Steel 183 (1269)
Freeze-thaw	ASTM E2485/ICC-ES Proc. ICC ES (AC 212)*	No deleterious effects after 10 cycles	Pass: Plywood, Cement Board, OSB, Exterior Gypsum (ASTM C79/C1396) and Dens Glass Gold (ASTM C1377) substrates
Water Resistance	ASTM D2247 ICC ES (AC 212)*	No deleterious effects after 14 days exposure ¹	Pass: Plywood Cement Board, OSB, Exterior Gypsum (ASTM C79/C1396) and Dens Glass Gold (ASTM C1377) substrates
Water Vapor Transmission	ASTM E96 Proc. B ICC ES (AC 212)*	Vapor Permeable	30 perms (Rollershield RS) ² 12 perms (Rollershield TG) 0.07 perms desiccant (A), 1.35 perms water (B)(Rollershield VB)
Air Permeance	ASTM E2178	No ICC or ANSI/EIMA Criteria ASHRAE/IECC max. 0.004 cfm/ft ² @ 1.57 psf	0.001 cfm/ft ² @ 1.57 psf 0.001 L/s/m ² @ 75 Pa
Air Leakage	ASTM E2357	No ICC or ANSI/EIMA Criteria ASHRAE/IECC max. 0.04 cfm/ft ² @ 1.57 psf	0.0006 cfm/ft ² @ 1.57 psf, 0.003 L/s/m ² @ 75 Pa 0.04 cfm/ft ² @ 6.24 psf, 0.02 L/s/m ² @ 300 Pa
Structural Performance	ASTM E1233 Proc. A ICC ES (AC 212)*	Minimum 10 positive cycles at 1/240 deflection; No cracking in field, at joints or interface with flashing	Pass
Racking	ASTM E72 ICC ES (AC 212)*	No cracking in field, at joints or interface with flashing at net deflection of 3.2 mm (1/8 inch)	Pass
Restrained Environmental	ICC-ES Procedure ICC ES (AC 212)*	5 cycles; No cracking in field, at joints or interface with flashing	Pass
Water Penetration	ASTM E331 ICC ES (AC 212)*	No water penetration beyond the inner-most plane of the wall after 15 minutes at 137 Pa (2.86 psf)	Pass
UV Exposure	ICC ES Proc. ICC ES (AC 212)*	210 hours of exposure, rated for 6 months of exposure	Pass
Accelerated Aging	ICC ES Proc. ICC ES (AC 212)*	25 cycles of wetting and drying	Pass
Hydrostatic Pressure Test	AATCC 127 ICC ES (AC 212)*	ICC: 549 mm (21.6 in) water column for 5 hours	Pass
Surface Burning Characteristics	ASTM E84	Flame Spread < 25 Smoke Developed < 450	Pass
Intermediate Multi-Story Fire Test	NFPA 285 (UBC 26-9)	No flame spread with up to 4" insulation	Pass
Nail Sealability	ASTM D1970	Standard Specification for Self-Adhering Polymer Modified Bituminous Sheet Materials Used as Steep Roofing Underlayment for Ice Dam Protection	Pass (22 mils)
Heat and Smoke Release Rates	ASTM E1354, IBC Section 1403.5, Exception 2 Requirements	Peak Heat Release Rate <150 kW/m ² , Total Heat Release Rate <20 MJ/m ² , Effective Heat of Combustion <18 MJ/kg	RS: Peak Heat Release Rate = 32 kW/m ² , Total Heat Release Rate = 3.6 MJ/m ² , Effective Heat of Combustion = 2.5 MJ/kg, VB: Peak Heat Release Rate = 336 kW/m ² , Total Heat Release Rate = 8.8 MJ/m ² , Effective Heat of Combustion = 9.3 MJ/kg

* (AC212 – Acceptance Criteria for Water-Resistive Coatings Used as Water-Resistive Barriers over Exterior Sheathing, also referred to as ASTM E 2570

1. No cracking, checking, rusting, crazing, erosion, blistering, peeling, or delamination when viewed under 5x magnification

2. Defined as a Class III vapor retarder per the 2015 IBC and IRC





Master Wall Inc.®
Building a Culture of Excellence

PRODUCT DATA

SUPERIORSHIELD ROLLERSHIELD-RS

SuperiorShield Rollershield-RS is a high quality 100% acrylic flexible fluid applied air and water barrier that is easily applied with a roller or spray equipment but also can be troweled or brushed into place. Rollershield-RS forms a continuous air and water barrier that protects approved substrates from incidental water damage.

FEATURES & BENEFITS

- Used as an air/water barrier in Rollershield LAB applications or as part of the Rollershield Drainage CIFS® System
- 100% Coverage, Fully adhered to substrate
- Vapor open/permeable with low air infiltration rate
- Used as water barrier and flashing, 60-minute Grade D equivalent
- Compatible with other SuperiorShield products; Rollershield-TG (Trowel Grade), Rollershield-VB, SuperiorFlash and WeatherSTOP Tape
- Adheres to most common building materials
- Easy to apply, water based for easy cleanup
- Exposure up to 6 months
- Low VOC, <1% by weight, 10 g/L

Application Temperature: 25° -110°F (-3.8° -43°C)

Dry to Touch: 1 hour @ room temperature

Recoat Time: 2 hours @ room temperature

Drying Time: 12 hours @ room temperature, working and drying time will vary with temperature and humidity.

JOB CONDITIONS

Air and substrate temperature for application of Rollershield-RS must be 40°F (5°C) or higher and must remain 40°F (5°C) or higher for a minimum of 24 hours unless special procedures are used. Provide temporary protection to protect the wall system from damage until permanent flashings, caps and sealants are installed. Store materials within prescribed temperature limits and out of direct sunlight. Working and drying times are based upon normal room temperature conditions and will vary with temperature and humidity.

PREPARATION

The substrate must be approved by Master Wall Inc.®, clean, dry, structurally sound, and free of efflorescence, oil, grease, form release agents and curing compounds or anything that would affect bond. Painted surfaces are not acceptable and must be removed or bond test performed. Substrates must be flat and free of fins or planar irregularities greater than 1/4" in 10'-0" (6.35 mm in 3.05 m).

Coverage per pail (sf/sm)*

Roller: 450-500 sf (42-46 sm)

Spray: 300-350 sf (28-32.5 sm)

Trowel: 200-250 sf (18-23 sm)

**All coverage is approximate for a single coat of 15 mils wet film thickness (WFT), 10 mils dry and depend upon substrate, details and individual application*

Packaging/Shelf Life/Storage

Packaging: 5 gallon (19L) pail

Product Color: Naranja Durazno

Shelf Life: 2 years

Storage: Protect from extreme heat: 90°F (32°C), freezing and direct sunlight.

APPLICATION PROCEDURE

Concrete – Must have cured a minimum of 28 days prior to the application of Rollershield-RS. If form release agents or curing compounds exist on the surface, they must be removed with a solution of muriatic acid or similar product (with appropriate precautions). Remove any residual acid by flushing with water.

Brick/Masonry – If joints are not struck flush, multiple coats may be required. Porous CMU may require additional coats.

Sheathing Applications - Sheathing gaps must be less than 1/4" (6.4 mm). See Technical Bulletin #189 for larger gap suggestions. Gap wood-based sheathing per manufacturers recommendations, typically 1/8" (3.2 mm) minimum.

Mixing - Thoroughly stir Rollershield-RS into a homogenous consistency. Do not add water, over mix, or add accelerators or retarders to the product.

Application – Rollershield-RS is applied by first treating the joints and fastener locations where sheathing is used, then coating the entire surface using brush, roller, trowel, or airless spray equipment techniques. When using a foam roller, a maximum 3/4" (19 mm) nap is recommended. Apply in an even, continuous coat, maintaining a wet edge of approximately 15 mils wet film thickness (WFT). Oriented Strand Board and other porous substrates will require two (2) coats of Rollershield-RS. For moisture protection, apply Rollershield-RS as a continuous barrier of 10 mils dry thickness with no breaks or skips, although some areas will appear lighter than others due to the application process. The application need not look like a painted surface.

Joint Treatment—Apply a thin layer of Rollershield-RS to the joints and embed SuperiorShield Flashing Tape into the wet mixture and trowel smooth. Alternatively place and center SuperiorShield Mesh over all joints, corners, and gaps in the substrate. Immediately apply Rollershield-RS over the mesh and allow to dry.

Rollershield-RS may be flashed into window, door and other openings using the same techniques for sheathing applications. Any remaining gaps should be filled with additional Rollershield-RS, TG (Trowel Grade) or SuperiorFlash.

Wall Treatment—Apply Rollershield-RS to the wall surface using the foam roller, trowel or by spray applying and backrolling to a uniform thickness of 15 mils WFT, 10 mils dry with no pinholes or voids.

Hazard: This chemical is not considered hazardous according to the OSHA Hazard Communication Standard 2012 (29 CFR 1910.1200).

Approved Substrates

Exterior gypsum sheathing (ASTM C1396)

Glass Fiber Exterior Sheathing (ASTM C1177): Dens Glass Gold®, GlasRoc®, FiberBond®, Gold Bond e2xp®, etc.

Cement Board Substrates (ASTM C1325): Durock®, PermaBase®, ProTEC®, SelectCrete, Util-A-Crete®, etc.

Concrete

Brick

Masonry

Exterior Plywood

Oriented Strand Board (OSB)

Huber Zip (See Data Sheet for Specifics)

Most metals and PVC

Others approved in writing

Compatible SuperiorShield Components

Rollershield-TG

SuperiorFlash

SuperiorShield Flashing Tape

SuperiorShield Mesh

WeatherSTOP Tape

Sealant Bond Compatibility**

Adfast Corp.: Adseal DWSP1940 Series***, Adseal 4600, Adseal 4580, Adseal 1940

Dow Corning: 795 Silicone**

Pecora Corp.: 864NST, 890NST, 890FTS, 895NST^A, Dynatrol I-XL Hybrid^B

Sika: Silaflex 15 LM***, Silaflex-2C NS***

Master Builders Solutions: MasterSeal NP1***

Tremco: Dymonic 100***

Most polyurethane sealants**

See Technical Bulletin MW#131 for latest sealant information

**field verify bond (varies)

***Also bonds to SuperiorFlash

^AWith P120 Primer with Rollershield RS & TG

^BWith P120 Primer with Rollershield VB

SPECIALTY APPLICATION - MEDIUM AND HIGH BUILD

Application for Medium-Build Specification: apply one or two coats to achieve minimum 20 mils wet film thickness (WFT). If applied by roller apply two coats to achieve minimum 20 mils WFT. For CMU substrates apply two or three coats to achieve 20-60 mils WFT.

Application for High-Build Specification: apply two or three coats to achieve 40 mils WFT. If applied by roller apply three or more coats as needed. For CMU substrates apply multiple coats to achieve 40-60 mils WFT.

IMPORTANT: the condition of the substrate may dictate thicker application or more coats to achieve a VOID and PINHOLE FREE SURFACE, particularly on substrates like concrete masonry where CMU composition, unit weight (lightweight or normal weight), porosity, joint profile, and other variables may exist. For “rough” CMU wall surfaces level with Master Wall Base Coat before applying the coating. Use the mock-up and site tests as the basis for the work. Some highly absorbent glass mat gypsum sheathing substrates may require back rolling to achieve a VOID and PINHOLE FREE surface. Avoid excess film build-up of wet material to prevent sag, especially on non-porous surfaces and during cold or damp weather. Work away from sun during application.

SPECIALTY APPLICATION - COLD WEATHER

Special Instruction for Cold Temperature Application: Master Wall Rollershield may be applied at temperatures less than 40° down to 25° F (4° down to -3.8°C), provided certain conditions are met:

1. Pre-condition Rollershield-RS to 65°-75° F (18°-24° C) for a minimum of 24 hours.
2. Confirm and maintain substrate and ambient temperatures are minimum 25° F (-3.8°C) and rising at the time of application and do not fall below 25° F (-3.8°C) until Rollershield-RS is fully dry.
3. Apply Rollershield-RS over standard sheathing substrates – glass mat gypsum, plywood, or OSB.
4. Confirm substrate surfaces are frost-free, dry and remain dry throughout the application and curing process.
5. Apply Rollershield-RS at a wet film thickness of no greater than 15 mils WFT.
6. Apply Rollershield-RS with Master Wall SuperiorShield Flashing Tape for joint and rough opening treatments.
7. Apply in dry weather and protected from rain or other precipitation for at least 24 hours and relative humidity (RH) remains at or below 50%. **IMPORTANT:** Final water-resistive barrier and air barrier material properties, and film toughness, depend on temperatures rising above freezing.

COLD WEATHER LIMITATIONS

Application range is at ambient temperatures between 25° and 100° F (-3.8° and 38° C) during application and drying period. Strictly adhere to Special Instructions for Cold Temperature Application if installing below 40° F (4° C).

Do not apply if substrate or ambient temperature is less than 25° F (-3.8°C), or if temperatures will go below 25° F (-3.8°C) at any time during the application or drying period.

Do not apply if the surface temperature is less than 5° F (2.8°C) above the ambient dew point temperature.

Technical Data

Solids Content: 69.52% solids by wt (55.05% by volume)

Tensile Bond, ASTM C297/E2134/AC212: 30-200 psi

Freeze-thaw ASTM E2485/AC212: Pass

Water Resistance, ASTM D2247/AC212: Pass

Water Vapor Transmission, ASTM E96 Proc. B/AC212: 30 perms** @ 10 mils, 15 perms @ 20 mils

Air Permeance, ASTM E2178: 0.001 cfm/ft² @ 1.57 psf, 0.001 L/s/m² @ 75 Pa

Air Leakage, ASTM E2357: 0.0006 cfm/ft² @ 1.57 psf (0.003 L/s/m² @ 75 Pa), 0.04 cfm/ft² @ 6.24 psf (0.02 L/s/m² @ 300 Pa)

Structural Performance, ASTM E1233/AC212: Pass

Racking, ASTM E72/AC212: Pass

Restrained Environmental, AC212: Pass

Water Penetration, ASTM E331/AC212: Pass

UV Exposure: Rated to 6 months

Accelerated Aging, AC212: Pass

Hydrostatic Pressure Test, AATCC 127/AC212: Pass

Surface Burning Characteristics, ASTM E84: Flame Spread < 25, Smoke Developed < 450

Intermediate Multi-Story Fire Test, NFPA 285 (UBC 26-9): Pass

Nail Sealability, ASTM D1970: Pass @ 22 mils

Heat and Smoke Release Rates, ASTM E1354, IBC Section 1403.5: Peak Heat Release Rate = 32 kW/m², Total Heat Release Rate = 3.6 MJ/m², Effective Heat of Combustion = 2.5 MJ/kg

** Defined as a Class III vapor retarder per IBC and IRC

LIMITATIONS

Not for use as an exterior finish, note exposure limitations on front page.

When adhering Rollershield Drainage CIFS® to the surface assure it is clean, dry, and free of surface contamination. Remove any dirt or surface contamination before adhesive attachment.

Allowable in-service temperature range: -40° to 180° F (-40° to 82° C).

Fire-retardant or pressure treated plywood must be dry with surface free of salts or other chemicals migrating from within the wood. Test adhesion to be sure of desired results.

Use a slip sheet, typically one layer of building paper between Rollershield-RS and stucco or adhered masonry veneer over metal lath.

SPRAY APPLICATION

Rollershield-RS is compatible with GRACO and Titan airless spray equipment with the following specifications:

- Minimum 1 gallon per minute output.
- Minimum hose width of 3/8 inch.
- Minimum tip size of 0.027–0.031.

Minimum pressure requirement to spray of 2,000 psi at the gun with an airless sprayer rated no lower than 3,300 psi. Remove all filters in sprayer and gun before application.

Hopper Gun: 3/16"-1/4" (6-6.5 mm) orifice, 23-25 psi.

CLEAN UP

Tools and equipment can be cleaned with soapy water when Rollershield-RS is wet.

Information contained in this product data sheet conforms to the standard detail recommendations and specifications for the installation of Master Wall Inc.® products and is presented in good faith. Master Wall Inc.® assumes no liability, expressed or implied as to the architecture, engineering, or workmanship of any project. This information may be concurrent with, or superseded by other applicable documents, such as specifications and details. Contact Master Wall Inc.® for the most current product information. ©2023 Master Wall Inc.®



Health & Safety

WARNING!

Causes eye and skin irritation.

Precautionary Statement

Wash hands thoroughly after handling. Wear protective gloves/protective clothing/eye protection/face protection.

FIRST AID MEASURES

Eye: Contact Rinse thoroughly with water as necessary. Get medical attention immediately if symptoms occur.

Skin: Contact Wash off with water. Consult a physician if necessary.

Inhalation: Move to fresh air. If symptoms arise, call a physician.

Ingestion: Clean mouth with water and afterwards drink plenty of water. Do NOT induce vomiting.

Consult a physician. Never give anything by mouth to an unconscious person.

Store locked up. Dispose of contents/container in accordance with Local, State, Federal and Provincial regulation.

Spills: Collect with suitable absorbent material such as cotton rags.

Disposal: Dispose of in accordance with local, state or federal regulations.

Warning: KEEP CONTAINER CLOSED WHEN NOT IN USE. KEEP OUT OF THE REACH OF CHILDREN. NOT FOR INTERNAL CONSUMPTION. FOR INDUSTRIAL USE ONLY.

Consult the Safety Data Sheet (SDS) in the Products section at masterwall.com for further health and safety information.

LIMITED WARRANTY

This product is subject to a written limited material or system warranty. Obtain a warranty from the Tech Support tab of our website. Refer to Specifications for more complete information on proper use and handling of this product.



Master Wall Inc.
Building a Culture of Excellence

PRODUCT DATA

SUPERIORSHIELD FLASHING TAPE

Lightweight non adhesive roll flashing material with superior strength and the ability to bridge most gaps or voids common in construction. Embedded into wet Rollershield-RS, TG or VB, it is used at flashing transitions with Master Wall® SuperiorShield Liquid Air/Water Barrier (LAB) and as part of Rollershield Drainage CIFS® applications. The tape easily embeds into wet Rollershield and dries to a highly reinforced yet flexible flashing.

FEATURES & BENEFITS

- Lightweight
- Strong
- Embeds easily
- Thin, will not build up wall surface
- Compatible with Rollershield RS, TG, VB and SuperiorFlash products

JOB CONDITIONS

Air and substrate temperature for application of SuperiorShield Flashing Tape must be 40°F (5°C) or higher. Follow Rollershield-RS, TG or VB temperatures and condition requirements.

PREPARATION

General—The substrate must be clean, dry, structurally sound, and free of efflorescence, oil, grease, form release agents and curing compounds. Test painted surfaces to verify bond.

Temporary Protection – Protect from weather until the Rollershield-RS, TG or VB products have set up.

Surface Preparation - Surface temperature must be above 40°F (5°C). Surface must be cured, clean, dry, structurally sound, and free of efflorescence, oil, grease, form release agents, and curing compounds.

Coverage estimate*

4x8 sheets: Square Footage x 0.37 = linear feet of tape

Add linear footage around windows, doors, and other openings.

**All coverage is approximate and depend upon substrate, details and individual application*

Roll Sizing/Packaging/Shelf Life/Storage

4"x180' (10.2cm x 54.9m)

6"x180' (15.2cm x 54.9m)

9"x180' (22.9cm x 54.9m)

Packaging:

4": 18 rolls per case.

6" & 9": 12 rolls per case.

Shelf Life: 2 years plus

Storage: Protect from extreme heat (90°F (32°C)), and direct sunlight.

APPLICATION PROCEDURE

General - SuperiorShield Flashing Tape is embedded into wet Rollershield-RS, TG or VB at flashing transitions (sheathing to framing, flashing, penetrations, etc.) and at sheathing board joints. Apply a generous layer of the product using a trowel, brush or roller and immediately embed the SuperiorShield Flashing Tape into the product and draw it tight and smooth working from the center to the edges.

Windows – The unique properties of the SuperiorShield air/water barrier system allows window flashing prior to the Rollershield wall application. Apply Rollershield and center SuperiorFlash Flashing Tape to provide at least at least 1” (25 mm) bond to the window flange and substrate on either side of the window opening. Use a “butterfly” at corners to complete the application making sure it covers all corner joints. For best results make sure the Rollershield covers the entire head, jamb, and sill areas. The use of sill wedges or water stops is encouraged.

Sheathing Applications – Apply Rollershield at least 2” (51 mm) either side of the sheathing board joint. Immediately embed the SuperiorShield Flashing Tape into the wet Rollershield and smooth with a trowel, centering it over the joint. Provide at least at least 1” (25 mm) bond either side of the sheathing joint. Lap Rollershield Mesh Tape 2” (51 mm) minimum Rollershield field application can begin as soon as the Rollershield is dry to the touch.

Information contained in this product data sheet conforms to the standard detail recommendations and specifications for the installation of Master Wall Inc.® products and is presented in good faith. Master Wall Inc.® assumes no liability, expressed or implied as to the architecture, engineering, or workmanship of any project. This information may be concurrent with, or superseded by other applicable documents, such as specifications and details. Contact Master Wall Inc.® for the most current product information. ©2022 Master Wall Inc.®



Hazard: This chemical is not considered hazardous according to the OSHA Hazard Communication Standard 2012 (29 CFR 1910.1200).

VOC: Less than 50 g/L.

Approved Materials for Embedment

Rollershield-RS
Rollershield-TG
Rollershield-VB
Others approved in writing

LIMITED WARRANTY

This product is subject to a written limited material or system warranty. Obtain a warranty from the Tech Support tab of our website. Refer to Specifications for more complete information on proper use and handling of this product.

220701



HUNTER
CONTINUOUS INSULATION

Hunter Panels Xci CG

Polyisocyanurate Insulation Manufactured On-Line to Coated Glass Facers
for Exterior Commercial Wall Applications

HUNTER PANELS Xci CG

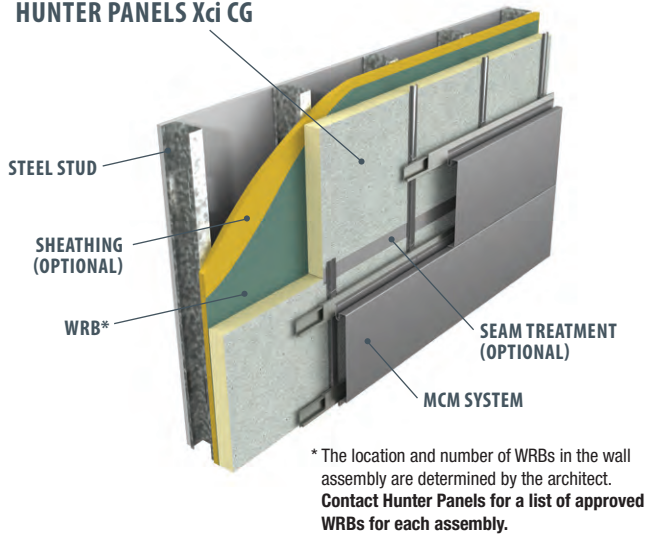

Xci CG Thermal Values

Thickness (inches)	Thickness (mm)	R-Value
1.0	25	6.0
1.5	38	9.0
2.0	51	12.1
2.5	64	15.3
3.0	76	18.5
3.5	89	21.7
4.0	102	25.0

Thermal values as per ASTM C 518 in accordance with ASTM C 1289.

Description

Xci CG is an energy efficient rigid insulation panel composed of a closed cell polyisocyanurate foam core manufactured on-line to premium performance coated glass facers on both sides. It is designed for use in commercial wall applications to provide continuous insulation within the building envelope.

Premium Performance Attributes

- Polyiso offers increased R-value per inch vs mineral fiber, XPS or EPS options
- Designed for use in continuous insulation to assist in meeting the most current ASHRAE 90.1, IECC, IBC and IRC standards
- Manufactured with NexGen Chemistry: Zero Ozone Depleting Potential (ODP); Contains no CFCs, HCFCs or HFCs; Virtually zero Global Warming Potential (GWP). Use of Xci products helps reduce the carbon footprint of buildings.
- Superior fire performance, durability, dimensional stability, and resistance to mold growth

Applications

- Provides continuous insulation (ci) for standard wood frame, FRT wood frame, steel stud, CMU and concrete exterior wall constructions
- Compatible with numerous claddings/finishes including masonry, fiber cement, stucco, terra cotta, mcm, metal, natural stone, stone aluminum, EIFS
- Underslab, below-grade and sandwich panel applications

Note: Xci CG is not suitable for exposed interior applications.

Panel Characteristics

- ASTM C 1289 Type II, Class 2 Grade 2 (20 psi) or Grade 3 (25 psi)
- Available in 4' x 8' (1220mm x 2440mm) panels in thickness of 1" (25mm) – 4" (102mm)
- Other widths/lengths are available upon special request (for example: 16" or 24" width)

Codes and Compliances

- ASTM C 1289
- IBC Chapter 26 and IRC Section R316
- Numerous NFPA 285 compliant assemblies
- Numerous UL 263 hourly designs
- DRJ Technical Evaluation Report 1402-02
- Miami Dade County Product Control Approved
- California Code of Regulations, Title 24, Insulation Quality Standard License #TI-1420
- California Bureau of Furnishings and Home Insulation
- CCMC 13460-L; Type 1, Class 3
- **UL Classified for use in Canada**
– Refer to UL Director of Products Certified for Canada for more details
- CAN/ULC S-704 Type 2, Class 2

LEED Potential credits for Polyiso use

Energy and Atmosphere
• Optimize Energy Performance

Materials & Resources
• Building Life-Cycle Impact Reduction
• Environment Product Declaration
• Material Reuse
• 9% Pre-consumer Recycled Content
• Construction and Demolition Waste Management

Indoor Environmental Quality
• Thermal Comfort

Hunter Panels Xci CG

Polyisocyanurate Insulation Manufactured On-Line to Coated Glass Facers
for Exterior Commercial Wall Applications

Typical Physical Property Data Chart

Property	Test Method	Value
Compressive Strength	ASTM D 1621	20 psi* min. (138 kPa, Grade 2)
Dimensional Stability	ASTM D 2126	2% linear change (7 days)
Moisture Vapor Permeance	ASTM E 96	<1 perm (57.5ng/(Pa•s•m ²))
Air Permeance	ASTM E 2178	<0.001 L(s•m ²) at 75 Pa
Impact Resistance (Janka Ball Test)	ASTM D 1037	15
Water Absorption	ASTM C 209	< 0.1% volume
Service Temperature		-100° to 250° F (-73°C to 122°C)
Flame Spread Index (foam core)	ASTM E 84	<75
Smoke Developed (foam core)	ASTM E 84	<450
Resistance to Mold	ASTM D 3273	Passed (10)
Recycled Content		9% pre-consumer

*Also available in Grade 3 (25 psi)

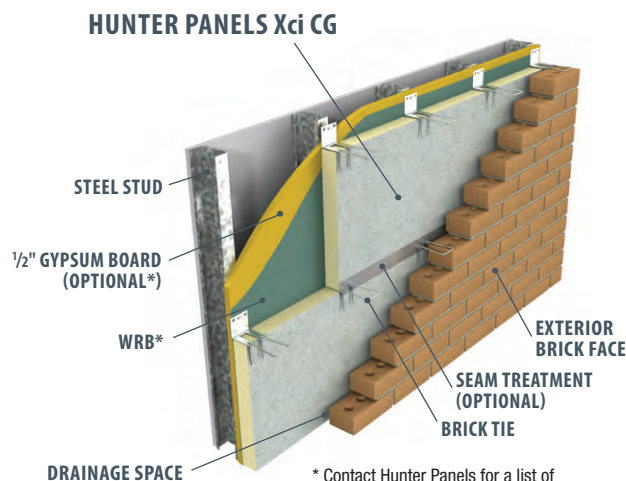

* Contact Hunter Panels for a list of approved WRBs and a complete list of assemblies where gypsum is not required.

Installation

- Xci CG is not a structural sheathing; exterior cladding must be attached through to the framing
- Always follow local codes for structural bracing
- Refer to local codes and practices for placement of the WRB in the wall assembly
- Follow cladding manufacturer's recommendation for attachment requirements
- Insulation installation may require separate fasteners or adhesives depending on the exterior cladding attachment
- Adhesives can be used for attachment to CMU, gypsum and concrete
- Metal furring strips can be installed on the exterior, fastened through the insulation to the structural wall to create a drainage plane
- Xci CG is compatible with most construction grade adhesives, sealants, caulks, tapes, and spray foams

Post-Installation Exposure

During the time frame between installation of Xci CG and the application of the finished exterior cladding, it is recommended that a building wrap be applied to the Xci CG. If a building wrap has not been specified, ALL UNFACED FOAM EXPOSED TO DIRECT DAYLIGHT (i.e. corners, window and door openings) should be taped with a compatible waterproof tape. Xci CG is not intended to be left exposed for extended periods of time (i.e. in excess of 60 days) without adequate protection. Please contact Hunter Panels for details.

WRB

The incorporation of Weather Resistant Barriers (air, vapor and moisture) is a critical element of a wall assembly. A design professional familiar with local code requirements should specify the selection and placement of any WRB. Furthermore, it is recommended that a hygrothermal analysis of the proposed assembly be conducted to determine the type and locations of a proposed WRB.

Note: The NFPA 285 fire test is an assembly test. The performance of the WRB must also be considered. Please consult Hunter Panels for details and specifications.

Job-Site Storage

Good construction practice dictates that all insulations should be protected from moisture and direct sunlight during job-site storage. Pallets of Hunter Panels Xci CG are double packaged in a UV resistant polyethylene bag. This moisture resistant package is designed for protection from the elements during flat bed shipment from our factories to the job-site. Outdoor storage for extended periods of time requires waterproof tarpaulins and elevated storage above ground level a minimum of 2". Additionally, we recommend slitting the bundle packaging vertically down the center of the two short sides to prevent moisture accumulation within the package.

Warnings and Limitations

Insulation must be protected from open flame. Hunter Panels will not be responsible for specific building design by others, for deficiencies in construction or workmanship, for dangerous conditions on the job site or for improper storage and handling. Technical specifications shown in this literature are intended to be used as general guidelines only and are subject to change without notice. Call Hunter Panels for more specific details.



Hunter Panels | Energy Smart Polyiso | 888.746.1114 | www.hunterpanels.com

New York Illinois Florida Texas Utah Pennsylvania Washington



HUNTER
CONTINUOUS INSULATION



HUNTER
CONTINUOUS INSULATION

Hunter Panels Xci Foil

Polyisocyanurate Insulation Manufactured On-Line to Foil Facers
for Exterior Commercial Wall Applications

HUNTER PANELS Xci FOIL

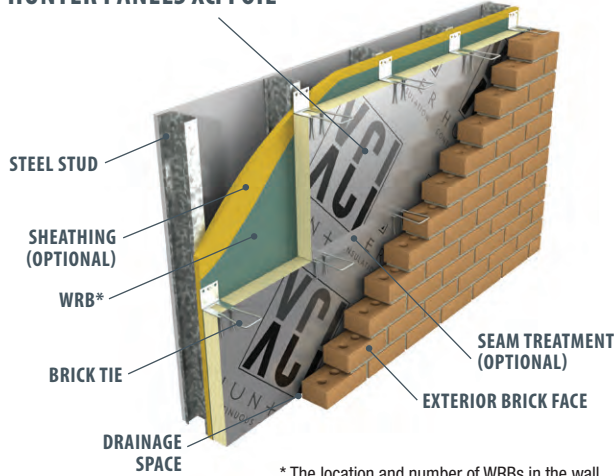

* The location and number of WRBs in the wall assembly are determined by the architect.
Contact Hunter Panels for a list of approved WRBs for each assembly.

Xci Foil Thermal Values

Thickness (inches)	Thickness (mm)	R-Value
1.00	25	6.5
1.50	38	10.0
2.00	51	13.3
2.50	64	17.0
3.00	76	20.3
3.50	89	24.0
4.00	102	27.0

Thermal values as per ASTM C 518 in accordance with ASTM C 1289.

Description

Xci Foil is an energy efficient rigid insulation panel composed of a closed cell polyisocyanurate foam core manufactured on-line to an impermeable foil facing material. It is designed for use in commercial and residential wall applications to provide continuous insulation within the building envelope.

Features and Benefits

- Polyiso offers increased R-value per inch vs mineral fiber, XPS or EPS options
- Designed for use in continuous insulation to assist in meeting the most current ASHRAE 90.1, IECC, IBC and IRC standards
- Manufactured with NexGen Chemistry: Zero Ozone Depleting Potential (ODP); Contains no CFCs, HCFCs or HFCs; Virtually zero Global Warming Potential (GWP). Use of Xci products helps reduce the carbon footprint of buildings.
- Lightweight yet durable, easy to handle. Cuts with a knife or saw.

Applications

- Provides continuous insulation (ci) for standard wood frame, FRT wood frame, steel stud, CMU and concrete exterior wall constructions
- Suitable for external ductwork
- Suitable for masonry cavity wall applications

Note: Xci Foil is not suitable for exposed interior applications.

Panel Characteristics

- Available in two compressive strengths per ASTM C 1289 Type 1, Grade 2 (20 psi) and Grade 3 (25 psi)
- Available 4' x 8' (1220mm x 2440mm) panels in thicknesses of 1" (25mm) – 4" (102mm)
- Other widths/lengths are available upon special request—(for example: 16" or 24" width)

Codes and Compliances

- ASTM C 1289
- IBC Chapter 26 and IRC Section R316
- Numerous NFPA 285 compliant assemblies
- Numerous UL 263 hourly designs
- DRJ Technical Evaluation Report 1402-02
- Miami Dade County Product Control Approved
- California Code of Regulations, Title 24, Insulation Quality Standard License #TI-1420
- California Bureau of Furnishings and Home Insulation
- CCMC 13460-L; Type 2, Class 1
- **UL Classified for use in Canada**
– Refer to UL Director of Products
Certified for Canada for more details
- CAN/ULC S-704 Type 1, Class 1

LEED Potential credits for Polyiso use

- Energy and Atmosphere**
 - Optimize Energy Performance
- Materials & Resources**
 - Building Life-Cycle Impact Reduction
 - Environment Product Declaration
 - Material Reuse
 - 9% Pre-consumer Recycled Content
 - Construction and Demolition Waste Management
- Indoor Environmental Quality**
 - Thermal Comfort

Hunter Panels Xci Foil

Polyisocyanurate Insulation Manufactured On-Line to Foil Facers
for Exterior Commercial Wall Applications

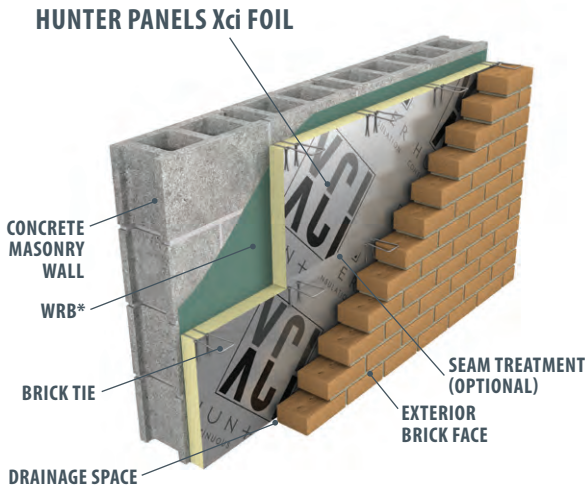

* The location and number of WRBs in the wall assembly are determined by the architect. Contact Hunter Panels for a list of approved WRBs for each assembly.

Typical Physical Property Data Chart

Property	Test Method	Value
Compressive Strength	ASTM D 1621	20 psi* min. (138 kPa, Grade 2)
Dimensional Stability	ASTM D 2126	2% linear change (7 days)
Moisture Vapor Permeance	ASTM E 96	<0.05 perm (2.875ng/(Pa•s•m ²))
Water Absorption	ASTM C 209	< 0.05% volume
Service Temperature		-100° to 250° F (-73°C to 122°C)
Flame Spread Index (foam core)	ASTM E 84	<75
Smoke Developed (foam core)	ASTM E 84	<450
Recycled Content		9% pre-consumer

*Also available in Grade 3 (25 psi)

R-Value Calculation – Cavity Wall Systems Comparison

	2" Polyiso	2.5" Polyiso	2" XPS
Inside Air Film	.68	.68	.68
8" Concrete Block	1.11	1.11	1.11
Insulation	13.30	17.00	10.00
4" Face Brick	.44	.44	.44
Outside Air Film	.17	.17	.17
Total Design R-Value	15.70	19.40	12.40

Installation

Install Xci Foil between the concrete block wall and the exterior masonry. Attach insulation panels against the inner wall using construction grade adhesive or mechanical attachment. Xci Foil may also be applied directly to oil based waterproofing adhesives.

Post-Installation Exposure

During the time frame between installation of Xci Foil and the application of the finished exterior cladding, it is recommended that a building wrap be applied to the Xci Foil. If a building wrap has not been specified, ALL UNFACED FOAM EXPOSED TO DIRECT DAYLIGHT (i.e. corners, window and door openings) should be taped with a compatible waterproof tape. Xci Foil is not intended to be left exposed for extended periods of time (i.e. in excess of 60 days) without adequate protection. Please contact Hunter Panels for details.

WRB

The incorporation of Weather Resistant Barriers (air, vapor and moisture) is a critical element of a wall assembly. A design professional familiar with local code requirements should specify the selection and placement of any WRB. Furthermore, it is recommended that a hygrothermal analysis of the proposed assembly be conducted to determine the type and locations of a proposed WRB.

Note: The NFPA 285 fire test is an assembly test. The performance of the WRB must also be considered. Please consult Hunter Panels for details and specifications.

Job-Site Storage

Good construction practice dictates that all insulations should be protected from moisture and direct sunlight during job-site storage. Pallets of Hunter Panels Xci Foil are double packaged in a UV resistant polyethylene bag. This moisture resistant package is designed for protection from the elements during flat bed shipment from our factories to the job-site. Outdoor storage for extended periods of time requires waterproof tarpaulins and elevated storage above ground level a minimum of 2". Additionally, we recommend slitting the bundle packaging vertically down the center of the two short sides to prevent moisture accumulation within the package.

Warnings and Limitations

Insulation must be protected from open flame. Hunter Panels will not be responsible for specific building design by others, for deficiencies in construction or workmanship, for dangerous conditions on the job site or for improper storage and handling. Technical specifications shown in this literature are intended to be used as general guidelines only and are subject to change without notice. Call Hunter Panels for more specific details.

Note: Xci Foil is not intended for use below grade.



Hunter Panels | Energy Smart Polyiso | 888.746.1114 | www.hunterpanels.com

New York Illinois Florida Texas Utah Pennsylvania Washington



HUNTER
CONTINUOUS INSULATION

Cement Board Exterior Applications Guide

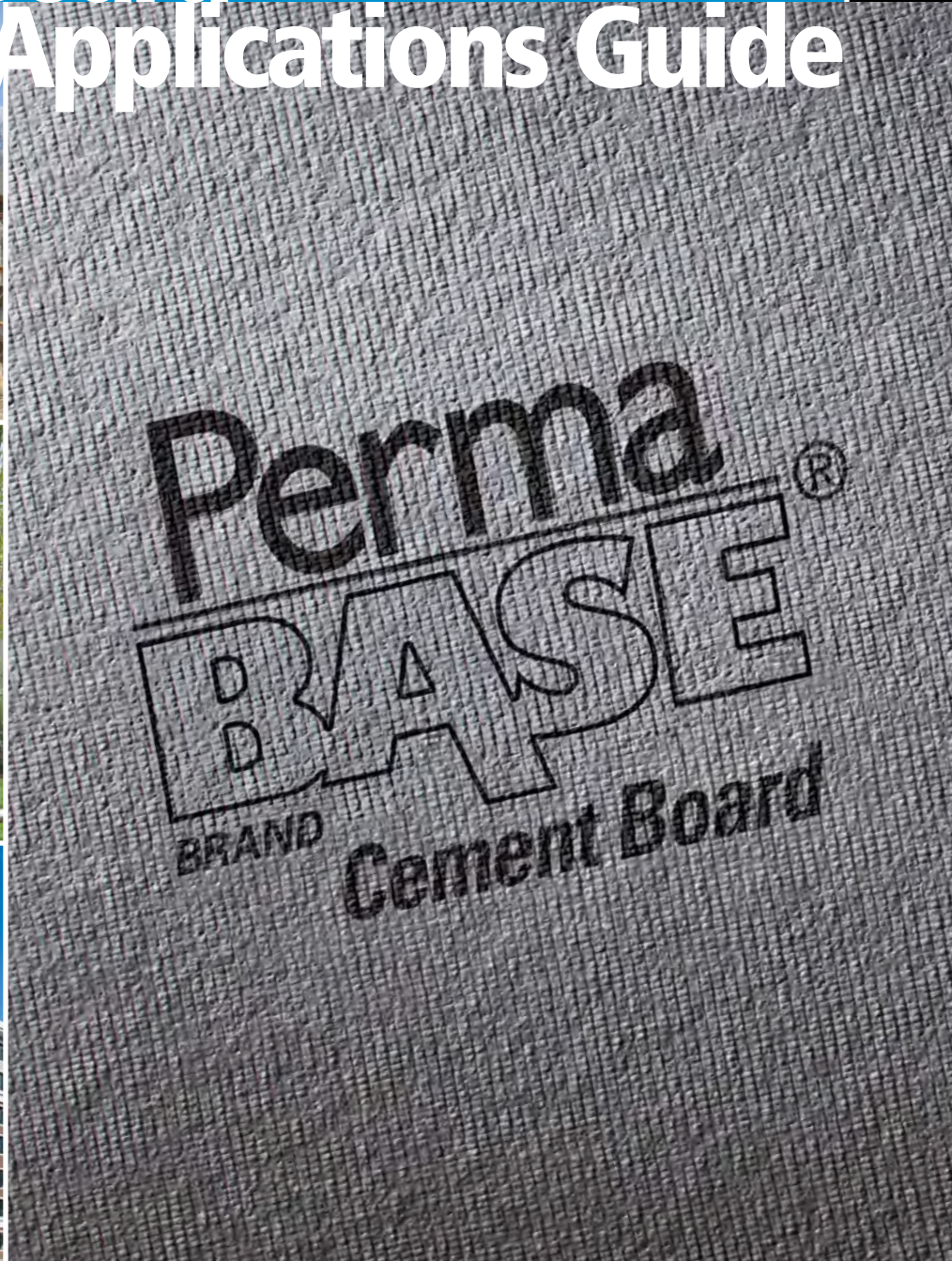

Building In Strength And Quality

Reinforce With The Best Rigid Substrate: PermaBase® BRAND Cement Board

PermaBase® provides a durable surface designed to withstand prolonged exposure to moisture. Made with Portland cement, aggregate and fiberglass mesh, it works well with exterior applications. Lightweight and easy to install, our EdgeTech® Technology allows a closer nail or screw application.



Resists Moisture Better

- Stays intact when exposed to water: will not rot, disintegrate or swell – built for the long run
- Achieves the industry's lowest water-absorption rating (ASTM C 473) – offering better installation
- Helps inhibit mold growth with the highest possible score on mold tests (ASTM D 3273 and ASTM G 21)



Stays Strong And Lasts Long

- Resists impact and remains dimensionally stable – extending the life of your project
- Holds up to the toughest conditions



Installs Quickly

- Lightweight and easy to cut – speeding up installation
- Reduces jobsite waste – easier, cleaner cut
- EdgeTech® Technology allows for a closer edge fastening and reduces damage from handling



Works For Exterior Projects – One Panel, Many Applications

- Adhere tile, stone or thin brick directly to PermaBase in exterior applications – saving time and money
- Durable substrate for direct-applied coating systems
- Meets UL classifications for one- and two-hour fire-rated assemblies
- Building code approved – one substrate that does the job of many



Offers Best In Class Warranty

- 15-Year Limited Warranty: Exterior applications

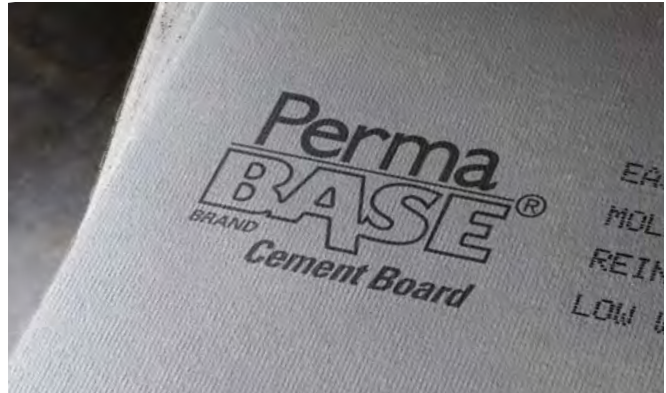

Quality To The Core

1. Reinforced Edge
2. Fiberglass Mesh
3. Cementitious Core

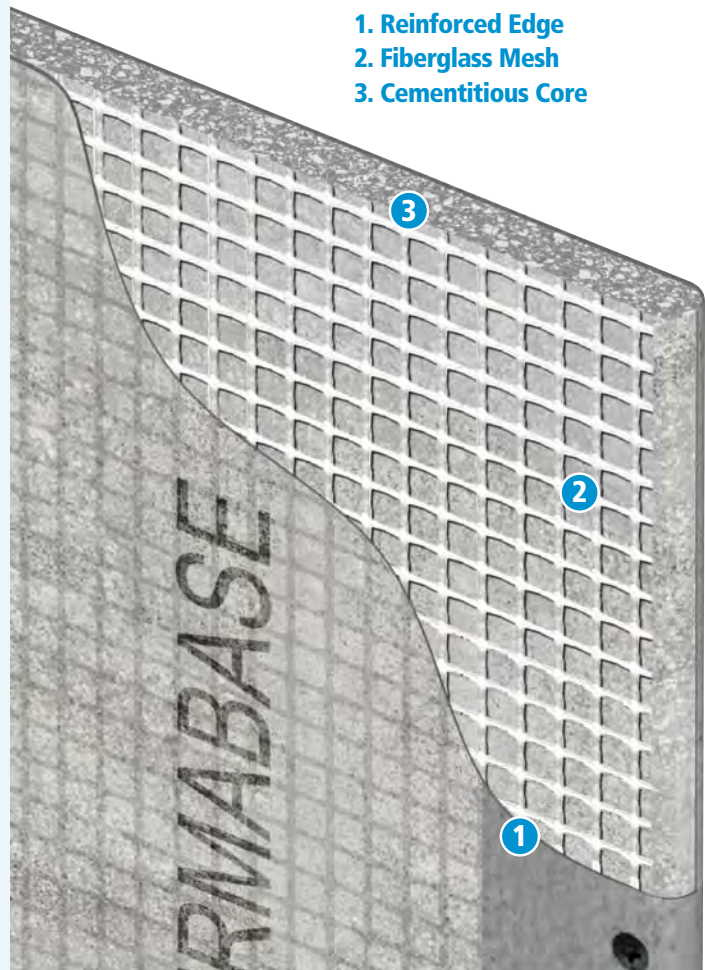

Cement Board Masonry Veneer Wall System (CBMV)

For use in residential and low-rise commercial applications, CBMV offers a complete, engineered solution for installation of adhered veneers. It provides the ability to incorporate an effective water-management system for a variety of building exteriors with manufactured or natural stone and thin brick veneers.

BENEFITS INCLUDE

- Engineered system that allows a faster installation while providing superior quality control (manufactured product that must comply with ASTM product specifications)
- Increased performance by utilizing modified adhesive mortars (designed for hanging materials) rather than type S&N mortars (developed for stacking materials)
- Extremely durable with increased resistance to impact and inclement weather
- Approved for use in ASTM 1780, and cement board is cited as an approved substrate for this system by the Masonry Veneer Manufacturers Association (MVMA): *Installation Guide and Detailing Options for Compliance with ASTM C1780*
- Easily allows for the inclusion of continuous installation into the assembly
- Appropriate for all climates, and resists the growth of mold and mildew

- Speed up your schedule – faster, easier and cleaner than traditional metal lath/scratch-coat method
- IBC/IRC compliant; meets ASTM C1325
- PermaBase® is approved as a substrate for direct applied finishes, tile, stone and thin brick in exterior applications, as outlined in UL Evaluation Report ER-22158
- PermaBase® is suitable for use in combustible and noncombustible construction under the IBC and IRC, as outlined in UL Evaluation Report ER-22158

LIMITATIONS

- Sheathing selection and installation varies according to type of wall construction
- Code-approved water/air resistive barrier (WRB) must be installed to protect the cavity (type and placement will vary per local building codes and/or manufacturer's specifications, installation guidelines and warranties)

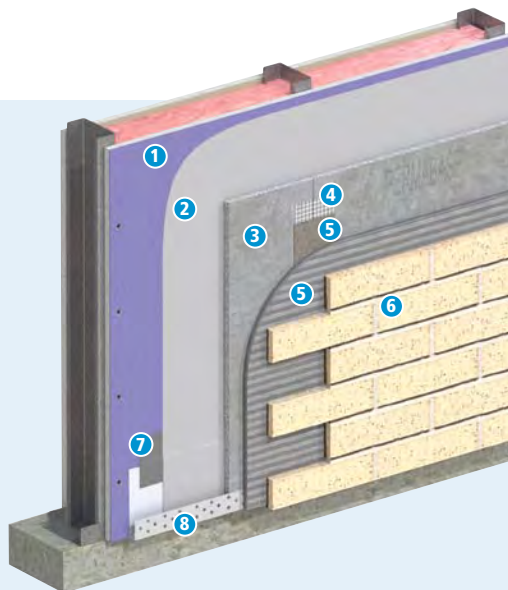

Cement Board Masonry Veneer-Thin Brick

- | | |
|------------------------------|----------------------|
| 1. EXP® Sheathing | 5. Mortar |
| 2. Weather Resistant Barrier | 6. Thin Brick Veneer |
| 3. PermaBase® Cement Board | 7. Flashing Tape |
| 4. Mesh Tape | 8. Weep Screed |

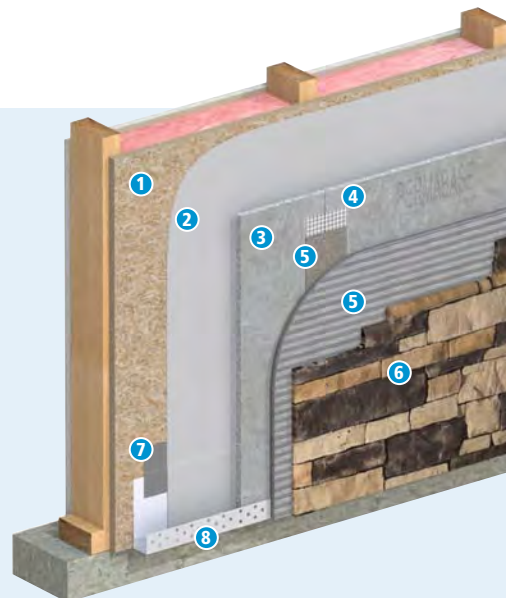

Cement Board Masonry Veneer - Stone

- | | |
|------------------------------|----------------------|
| 1. Sheathing | 6. Thin Stone Veneer |
| 2. Weather Resistant Barrier | 7. Flashing Tape |
| 3. PermaBase® Cement Board | 8. Weep Screed |
| 4. Mesh Tape | |
| 5. Mortar | |

Cement Board Stucco Wall Systems (CBSS)

For use in residential and low-rise commercial applications, CBSS provides a drainage system to help prevent water from penetrating behind cladding in framed construction. It complies with ASTM D226, protecting approved sheathings/structural components and helping to evacuate incidental water.

BENEFITS INCLUDE

- Appropriate for all climates and resists the growth of mold and mildew
- Extremely durable with increased resistance to impact and inclement weather
- Acrylic polymers provide more resistance to fading, cracking and peeling
- Engineered system that allows a faster installation while providing superior quality control (manufactured product that must comply with ASTM product specifications)
- Provides a 15-year exterior warranty – the industry's best

LIMITATIONS

- Follow finish material manufacturer's instructions for proper installation
- Treat joints in PermaBase[®] with mesh tape and base coat
- Thin veneer construction can reveal planar irregularities in framing
- Minor cracking at joints may become visible in finished exterior surface
- Exterior finishes applied directly to PermaBase[®]: Reinforcing mesh must be embedded in base coat (consult exterior finish manufacturer for additional installation requirements)
- Conventional Portland cement plaster systems: Self-furring metal lath must be used over PermaBase[®] and fastened to studs
- Code-approved water/air resistive barrier (WRB) must first be installed to protect the cavity (type and placement will vary per local building codes and/or manufacturer's specifications, installation guidelines and warranties)

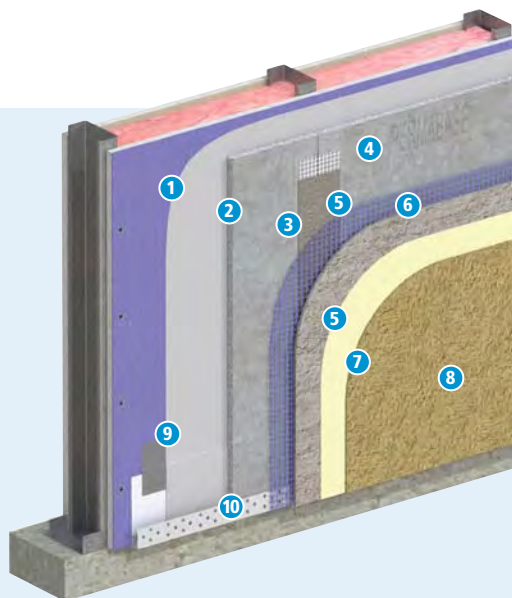

Cement Board Stucco

- | | |
|--|---------------------|
| 1. EXP [®] Sheathing | 6. Reinforcing Mesh |
| 2. Weather Resistant Barrier | 7. Primer |
| 3. PermaBase [®] Cement Board | 8. Finish Coat |
| 4. Mesh Tape | 9. Flashing Tape |
| 5. Base Coat | 10. Weep Screed |

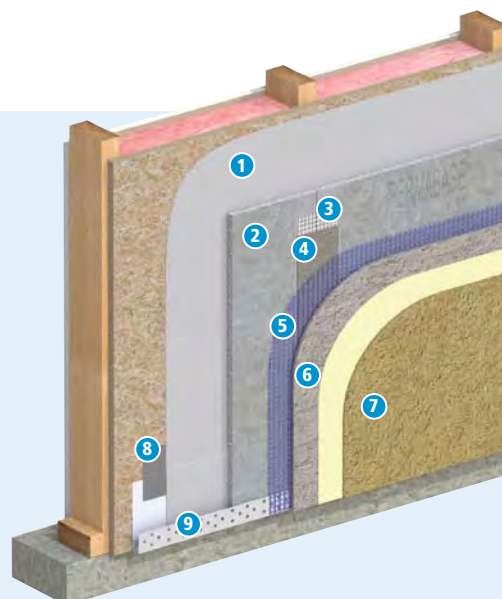

Wood Board Stucco

- | | |
|--|------------------|
| 1. Weather Resistant Barrier | 6. Base Coat |
| 2. PermaBase [®] Cement Board | 7. Finish Coat |
| 3. Mesh Tape | 8. Flashing Tape |
| 4. Base Coat | 9. Weep Screed |
| 5. Reinforcing Mesh | |

Continuous Insulation

For use in residential and low-rise commercial applications, Continuous Insulation offers a complete, engineered solution for required structural performance. Including PermaBase® as a component in this system reinforces the building and provides the ability to incorporate an effective water-management system.

NFPA 285 Approvals

PermaBase is approved for use in NFPA 285 wall assemblies. Approvals include the following finishes: stucco, manufactured stone, natural stone, thin brick, and calcium silicate stones. Assemblies include options for expanded polystyrene, extruded polystyrene, polyisocyanurate, and polyurethane insulations. For complete systems details, see UL Evaluation Report R22158.

BENEFITS INCLUDE

- Engineered system that allows a faster installation while providing superior quality control (manufactured product that must comply with ASTM product specifications)
- Helps mitigate the loss of heat/air conditioning by insulating the studs (reduces thermal bridging)
- Helps eliminate air and moisture leakage
- Appropriate for all climates, resists the growth of mold and mildew, and offers fire protection
- Provides added dimensional stability
- Helps prevent the water/air resistive barrier (WRB) from being compromised as assembly components shift
- Provides a 15-year exterior warranty – the industry's best

LIMITATIONS

- Sheathing selection and installation varies according to type of wall construction
- Code-approved water/air resistive barrier (WRB) must first be installed (type and placement will vary per local building codes and/or manufacturer's specifications, installation guidelines and warranties)

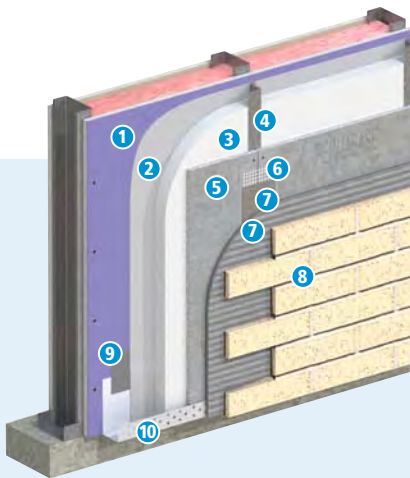

Continuous Insulation – Z Furring – Installation

- | | |
|------------------------------|----------------------|
| 1. EXP® Sheathing | 6. Mesh Tape |
| 2. Weather Resistant Barrier | 7. Mortar |
| 3. Insulation | 8. Thin Brick Veneer |
| 4. Z-Furring | 9. Flashing Tape |
| 5. PermaBase® Cement Board | 10. Weep Screed |

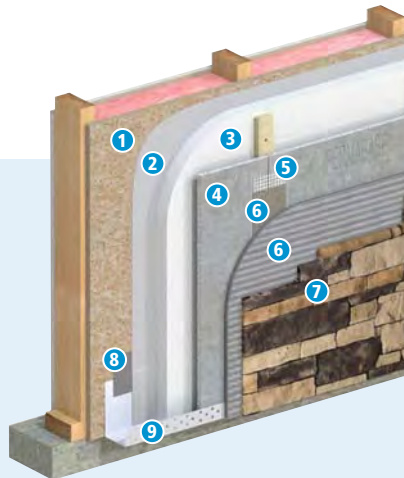

Continuous Insulation – Batten Strip

- | | |
|------------------------------|----------------------|
| 1. Sheathing | 6. Mortar |
| 2. Weather Resistant Barrier | 7. Thin Stone Veneer |
| 3. Insulation | 8. Flashing Tape |
| 4. PermaBase® Cement Board | 9. Weep Screed |
| 5. Mesh Tape | |

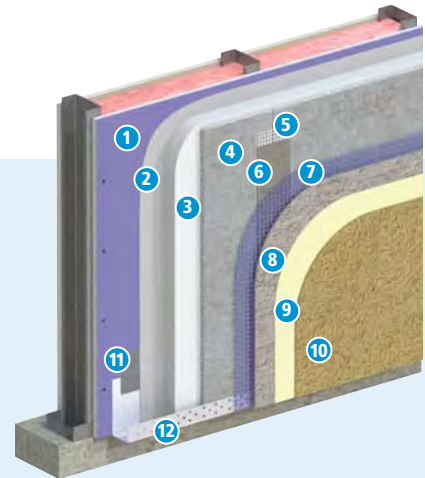

Continuous Insulation – Specialty Fastener

- | | |
|------------------------------|-------------------|
| 1. EXP® Sheathing | 6. Base Coat |
| 2. Weather Resistant Barrier | 7. Mesh |
| 3. Insulation | 8. Base Coat |
| 4. PermaBase® Cement Board | 9. Primer |
| 5. Mesh Tape | 10. Finish Coat |
| | 11. Flashing Tape |
| | 12. Weep Screed |

This section of the PermaBase Construction Guide provides information on how to utilize PermaBase within both a CBMV System and a Continuous Insulation System. While some typical examples are shown (right) for reference purposes, the specifications and details on how to design and construct individual systems should be obtained from the adhering material or veneer manufacturer of the materials that are being used to complete the system. [For more information, go to permaBase.com/exterior](http://permaBase.com/exterior).

Installation Guide

Exterior Applications

An ideal substrate for exterior applications, such as:

- Tile applications
- Stucco applications
- Cement board stucco
- Thin brick
- Adhered stone veneer
- Thin porcelain tile
- Ventilated rainscreen facade
- EIFS
- Continuous Insulation
- Outdoor kitchens/grills

INSTALLATION

General: All framing should comply with local building code requirements and be designed to provide support with a maximum allowable deflection of L/360 under all intended live (including wind) and dead loads.

Note: Cut or score PermaBase® on rough side of panel.

Control Joints: For exterior installations, allow a maximum of 16 lineal feet between control joints. Consult finish manufacturer for other requirements. For exterior tile applications, control joints should be spaced a maximum of every 12'. A control joint must be installed but not limited to the following locations: where expansion joints occur in the framing or building (discontinue all cross furring members located behind joint); when boards abut dissimilar materials; where framing material changes; at changes of building shape or structural system; at each story separation. Place control joints at corners of window and door openings, or follow specifications of architect. Control joint cavity shall not be filled with coating or other materials.

WALLS AND CEILINGS

Wall Framing: Studs should be spaced a maximum of 16" o.c. Edges/ends of PermaBase® parallel to framing should be continuously supported. Provide additional blocking when necessary to permit proper PermaBase® attachment. Do not install PermaBase® directly over protrusions from stud plane such as heavy brackets or fastener heads.

Ceiling Framing: The deflection of the complete ceiling assembly due to dead load (including insulation, PermaBase®, bonding material and facing material) should not exceed L/360. The dead load applied to the ceiling frame should not exceed 10 psf. Ceiling joist or furring channel should not exceed 16" o.c. (Edges of PermaBase® parallel to framing should be continuously supported.) Provide additional blocking when necessary to permit proper PermaBase® attachment.

Water Barrier: While PermaBase® is unaffected by moisture, a water/air resistive barrier (WRB) must be installed to protect the cavity. The type and specific placement or location of the water barrier will vary based on local building codes and/or manufacturers' warranties. Consult the WRB manufacturer's recommendations for specific installation guidelines.

PermaBase® Cement Board: Apply PermaBase® with ends and edges closely butted but not forced together. Stagger end joints in successive courses. Drive fasteners into field of cement board first, working toward ends and edges. Space fasteners maximum 8" o.c. into framing for walls, 6" o.c. into joists for ceilings with perimeter fasteners at least 3/8" and less than 5/8" from ends and edges.

Joint Reinforcement: Trowel bonding material to completely fill the tapered recessed board joints and gaps between each panel. On non-tapered joints, apply a 6" wide, approximately 1/16" thick coat of bonding material over entire joint. For all joints, immediately embed 4" alkali-resistant fiberglass mesh tape fully into applied bonding material and allow to cure. Same bonding material should be applied to corners, control joints, trims or other accessories. Feather bonding material over fasteners to fully conceal.

PHYSICAL PROPERTIES

Property Method	Test	1/4"	7/16" PLUS	1/2"	5/8"
Water Absorption % By Weight/24 Hours	ASTM C 473	<8	<10	<8	<8
Flexural Strength (psi)	ASTM C 947	>1750	750	750	>1000
Fastener Holding (Wet and Dry, lbs.) (0.400" head diameter)	ASTM D 1037	>85	>90	>90	>90
Weight (psf)	ASTM C 473	1.8	2.1	2.1	3.65
Freeze/Thaw (Cycles)	ASTM C 666	100	100	100	100
Flame Spread / Smoke Developed	ASTM E 84	0/0	0/0	0/0	0/0
Compressive Strength (psi) (Indentation)	ASTM D 2394	N/A	N/A	1450	1250
Wind Load	ASTM E 330	N/A	30	40	40
Thermal "R"/k Value	Property of Material	0.2/2.7	0.28/2.7	0.37/2.7	0.47/2.7
Bending Radius (ft.)	Property of Material	N/A	5	5	5
Falling Ball Impact	ASTM D 1037	Pass	Pass	Pass	Pass
Linear Variation (Due to change in moisture content)	ASTM D 1037	<0.07%	0.05%	0.05%	0.05%
Fungus Resistance	ASTM G 21	No Growth	No Growth	No Growth	No Growth
Mold Growth On Surface	ASTM D 3273*	10	10	10	10
Shear Bond Strength (7 Days psi) Dry-Set Portland Cement Mortar	ANSI A 118.1	N/A	N/A	204	N/A
Shear Bond Strength (7 Days psi) Latex Portland Cement Mortar	ANSI A 118.4	N/A	N/A	241	N/A
Shear Bond Strength (7 Days psi) Organic Adhesives Type 1	ANSI A 136.1	N/A	N/A	159	N/A

* When tested by an independent laboratory per ASTM D 3273 ("Standard Test Method for Resistance to Growth of Mold on the Surface of Interior Coatings in an Environmental Chamber"), PermaBase achieved a panel score of 10, the highest score possible, indicating no mold growth under the laboratory test conditions. The use of PermaBase in actual installations may not produce the same results as were achieved in controlled laboratory conditions. No material can be considered "mold proof," nor is it certain that any material will resist mold indefinitely.

SIZES AND PACKAGING

Size: Thickness, Width And Length	# Of Pcs Per Unit
PermaBase Cement Board	
1/2" x 32" x 5' (12.7 mm x 813 mm x 1524 mm)	50*
1/2" x 32" x 8' (12.7 mm x 813 mm x 2438 mm)	50
1/2" x 36" x 4' (12.7 mm x 914 mm x 1219 mm)	50*
1/2" x 36" x 5' (12.7 mm x 914 mm x 1524 mm)	50
1/2" x 36" x 6' (12.7 mm x 914 mm x 1829 mm)	50*
1/2" x 36" x 8' (12.7 mm x 914 mm x 2438 mm)	30*
1/2" x 48" x 8' (12.7 mm x 1219 mm x 2438 mm)	35
5/8" x 48" x 8' (15.9 mm x 1219 mm x 2438 mm)	24
5/8" x 36" x 5' (15.9 mm x 914 mm x 1524 mm)	35
3/8" x 36" x 5' (9.5 mm x 914 mm x 1524 mm)	50*
3/8" x 48" x 8' (9.5 mm x 1219 mm x 2438 mm)	40*
3/4" x 48" x 8' (19.0 mm x 1219 mm x 2438 mm)	20
PermaBase Underlayment	
1/4" x 48" x 4' (7.9 mm x 1219 mm x 1219 mm)	60
1/4" x 36" x 5' (7.9 mm x 914 mm x 1524 mm)	60

* Special Order

Installation Accessories

For a seamless installation, we recommend PermaBase Tape and PermaBase Screws.



Fasteners

PermaBase corrosion resistant screws or equivalent, 1-1/4" or 1-5/8" long, for use with wood framing. Type S-12 screws or equivalent, 1-1/4" or 1-5/8" long, for use with 20 gauge or heavier steel framing.

Galvanized roofing nails, 1-1/2" long with hot dipped galvanized coating for use with wood framing. Nails should meet Federal Specification #FF-N105B/type 2 style 20.

Joint Reinforcement

PermaBase mesh tape must be used on all edges and cuts made to size. Use 2" wide polymer-coated (alkali resistant) mesh tape for interior applications and 4" wide polymer-coated (alkali resistant) mesh tape for exterior applications.

Bonding Materials

Treat joint and set facing material, preferably with latex-Portland cement mortar or with dry-set (thin-set) mortar. All mortars should comply with ANSI A118.1, A118.4 or A118.15 standards. Type 1 organic adhesive meeting ANSI A-136.1 may be utilized for interior use only.

LIMITED WARRANTY AND REMEDIES

Products manufactured and sold by National Gypsum Company are warranted by National Gypsum Company to its customers to be free from defects in materials and workmanship at the time of shipment. THIS EXPRESS WARRANTY IS THE ONLY WARRANTY APPLICABLE TO SUCH PRODUCTS, AND IS IN LIEU OF AND EXCLUDES ALL OTHER EXPRESS ORAL OR WRITTEN WARRANTIES AND ALL IMPLIED WARRANTIES, INCLUDING BUT NOT LIMITED TO THE IMPLIED WARRANTIES OF MERCHANTABILITY AND FITNESS FOR A PARTICULAR PURPOSE.

National Gypsum Company will not be liable for any incidental, indirect or consequential losses, damages or expenses. The customer's exclusive remedy for any type of claim or action for defective products will be limited to the replacement of the products (in the form originally shipped) or, at National Gypsum's option, to a payment or credit not greater than the original purchase price of the products.

Mold And Mildew Resistance

PermaBase was designed to provide extra protection against mold and mildew. When tested by an independent laboratory, PermaBase received the highest possible ratings on ASTM G 21 and D 3273. The use of PermaBase in actual installations may not produce the same results as were achieved in controlled laboratory conditions. No material can be considered "mold-proof," nor is it

National Gypsum Company will not be liable for products claimed to be defective where the defect resulted from causes not within National Gypsum's control, or which arose or occurred after shipment, including but not limited to accidents, misuse, mishandling, improper installation, contamination or adulteration by other materials or goods, or abnormal conditions of temperature, moisture, dirt or corrosive matter.

Any claim that products sold by National Gypsum Company were defective or otherwise did not conform to the contract of sale is waived unless the customer submits it in writing to National Gypsum within thirty (30) days from the date the customer discovered or should have discovered the defect or non-conformance. No legal action or proceeding complaining of goods sold by National Gypsum may be brought by the customer more than one year after the date the customer discovered or should have discovered the defect or problem of which it complains.

certain that any material will resist mold or mildew indefinitely. When used in conjunction with good design, handling and construction practices, PermaBase can provide increased mold resistance. As with any building material, avoiding water exposure during handling, storage and installation, and after installation is complete, is the best way to avoid the formation of mold or mildew.

CUSTOMER SERVICE SALES AREAS

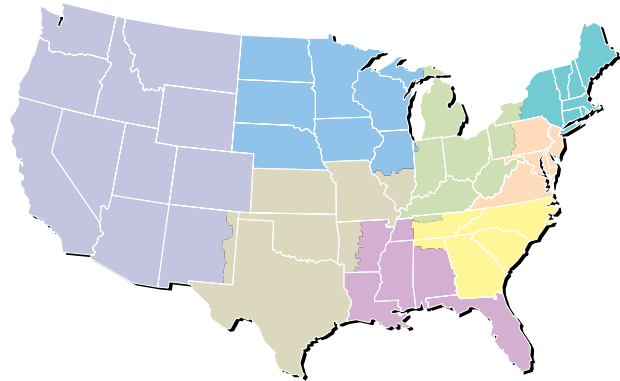

Atlantic Area

Phone: (800) 237-9167
Fax: (877) 252-0430

Central Area

Phone: (800) 252-1065
Fax: (866) 232-0440

Gulf Area

Phone: (800) 343-4893
Fax: (866) 482-8940

Midwest Area

Phone: (800) 323-1447
Fax: (866) 692-8590

Northeast Area

Phone: (800) 253-3161
Fax: (866) 632-1480

Southeast Area

Phone: (800) 548-9394
Fax: (866) 732-1990

Southwest Area

Phone: (800) 548-9396
Fax: (866) 792-7520

Western Area

Phone: (800) 824-4227
Fax: (800) 438-6266

National Accounts

Phone: (800) 440-1230
Fax: (866) 622-3590

Manufactured Housing

Phone: (800) 455-3185
Fax: (800) 639-1714



Perma
BASE[®]
BRAND
Cement Board

permabase.info



PRODUCT
CERTIFIED FOR
LOW CHEMICAL
EMISSIONS:
UL.COM/GG
UL 2818

Corporate Headquarters

National Gypsum Company
2001 Rexford Road
Charlotte, NC 28211
Phone: (704) 365-7300
Web: nationalgypsum.com

Technical Information

Phone: (800) NATIONAL
(800) 628-4662
Fax: (800) FAX-NGC1
(800) 329-6421

National 
Gypsum[®]



Master Wall Inc.®
Building a Culture of Excellence

PRODUCT DATA

ULTRABOND VENEER MORTAR ADHESIVE

UltraBond is a premium, polymer-fortified, adhesive mortar for the application of thin brick, synthetic and natural stone products, ceramic tile and quarry tile. UltraBond Veneer Mortar Adhesive mixes easily with water to a creamy consistency and is formulated with high initial grab and shear resistance.

FEATURES & BENEFITS

- Non-Sag
- Strong adhesion with Thin Brick and synthetic stone products
- Class leading shear bond strength
- Mixes easily with good open time
- Vapor Permeable - resists blistering and allows trapped water vapors to pass
- Freeze stable in dry form

Application Temperature: 40°-110°F (5°-43°C) Working Time: 1 hr. Set Time: 8-12 hrs. Dry Time: 12 hrs. at room temperature, working and drying time will vary with temperature and humidity.

SURFACE PREPARATION & MIXING

Job Conditions - Air and substrate temperature for application of UltraBond must be 40°F (5°C) or higher and must remain 40°F (5°C) or higher for a minimum of 24 hours. Provide temporary protection to protect the wall system from damage until permanent flashings, caps and sealants are installed. Store materials within prescribed temperature limits and out of direct sunlight. Working and drying times are based upon normal room temperature conditions and will vary with temperature and humidity.

Installer must verify that deflection IS L/360 minimum or greater in compliance with veneer structural requirements.

Preparation - The substrate must be approved by Master Wall Inc®, clean, dry, structurally sound and free of efflorescence, oil, grease, form release agents and curing compounds or anything that would affect bond. Painted surfaces are not acceptable and must be removed.

Mixing - Add 5 to 6 quarts (4.7-5.7 L) of potable water to a clean plastic pail. Add the UltraBond slowly while stirring using a heavy-duty 1/2" (12.7 mm) drill at 400 - 500 rpm and a heavy-duty mixer. Mix thoroughly to a homogeneous but stiff consistency. Let the mixture stand for 5 to 10 minutes and then remix without adding any more water or powder. During use, stir occasionally to keep mix fluffy. DO NOT temper with water. Excessive stirring may cause faster setting and reduced working time. Do not add accelerators or retarders to the UltraBond mixture.

Coverage per Bag *

1/4" x 3/8" (6 mm x 9 mm) Notched Trowel:
60-70 Ft², 5.6-6.5 m²

1/2" x 1/2" (12 mm x 12 mm) Notched
Trowel:
40-45 Ft², 3.7-4.2 m²

Adhered Masonry Veneer Application

Method:

30-33 Ft², 2.8-3.1 m²

**All coverage is approximate and depend upon substrate, details and individual application*

Packaging/Shelf Life/Storage

Packaging: 50 lb. (22.7 kg) bag

Shelf Life: 2 years

Storage: Protect from moisture and high humidity.

Technical Data

Compression (ASTM C270)

24 hours - 500 psi

7 day - 2700 psi

28 day - 3350 psi

Tensile (ANSI A118) Glazed/Mosaic

7 day - 315 psi / 305 psi

28 day - 500 psi / 290 psi

Shear Bond (ANSI A118.15) Glazed/Mosaic

7 day dry - 475 psi / 460 psi

7 day wet - 390 psi / 400 psi

28 day dry - 625 psi / 450 psi

Sag Resistance

(ISO 13007 24.2)

Quarry Tile - 0.0

Large Scale Tile - .485

Full Scale Stone - 0.0

Hazard: Considered hazardous by the 2012 OSHA Hazard Communication Standard (29 CFR 1910.1200)

VOC: Less than 50 g/L.

APPLICATION PROCEDURE

Prior to installation, ensure back of veneer units are clean of dust, laitance, loose concrete crumbs and any excess film that could impede bond. Porous and excessively dry substrates such as cement board, masonry or stucco may need to be wetted to avoid excessive absorption, allow to dry to the touch. Verify wetting requirements with the veneer manufacturer.

For adhered stone, thin brick and manufactured stone masonry veneers installations, use a gauging trowel to key a thin coat of UltraBond Veneer Mortar Adhesive to cover entire back of the veneer units. Spread additional mortar onto the back of the skim coated veneer sufficient to completely fill the space between the veneer and the substrate when compressed against the substrate (wet on wet). Press the mortar covered back of the veneer against the substrate at the desired final position. Slide the unit roughly 1 -1.5" (25-38 mm) diagonally from the desired final position and back into the desired position while maintaining even pressure. This should be done in such a manner as to squeeze the mortar to fill the entire space between the veneer unit and the substrate, allowing excess mortar to extrude on all sides around the veneer unit. Clean excess extruded mortar with trowel and spread onto the next veneer unit to be installed.

Alternate method for thin brick, tile, calcium silicate unit and stone installations: key UltraBond Veneer Mortar Adhesive into the substrate thoroughly. Then, comb on additional mortar with the notched side, use 1/4" x 3/8" (6 mm x 9 mm), 1/2" x 1/2" (12 mm x 12 mm) loop or notch trowel. Back butter all thin brick, veneer units 8" x 8" (200 mm x 200 mm), 3/4" (19 mm) loop trowel or larger to provide full bedding of the veneer. Place veneer into the mortar and adjust to desired position. Clean any excess mortar on sides of stone or tile veneer.

Note: Use proper sized notched trowel to ensure full bedding of the stone veneer. Spread only enough mortar for maximum coverage with tile within 15 -20 minutes. Trowel notch size determined by contractor, size of veneer and job-site coverage. Adjust as necessary. Check mortar for complete coverage by periodically removing veneer unit and inspecting the transfer onto substrate and back of the stone veneer. The size and weight of the veneer will vary. Due to job site conditions and differences in finish material types; ledger boards, shims, wedges or spacers may be required to maintain finish levels and heights.

Grouting/Pointing (if required) - When required, point installation after a minimum of 24 hours curing time at 70°F (21°C). With an approved premium grout or mortar.

Clean Up—Tools and equipment can be cleaned with soapy water while the UltraBond is still wet.

WARNING, THIS PRODUCT CONTAINS SILICA

If sanding or scraping are performed, ventilate work area and/or use a NIOSH/MSHA-approved respirator in accordance with our Safety Data Sheet.

Information contained in this product data sheet conforms to the standard detail recommendations and specifications for the installation of Master Wall Inc.® products and is presented in good faith. Master Wall Inc.® assumes no liability, expressed or implied as to the architecture, engineering, or workmanship of any project. This information may be concurrent with, or superseded by other applicable documents, such as specifications and details. Contact Master Wall Inc.® for the most current product information. ©2024 Master Wall Inc.®



Approved Substrates

Stucco (Scratch or Brown)
Mortar Parge Coat
Master Wall Base Coats
Durock®
PermaBase®
Util-A-Crete®
ProTEC®, ProGUARD®
Concrete
Brick
Masonry
Metal Lath
Adheres to Rollershield
Others approved in writing

Health & Safety

WARNING! Causes eye and skin irritation. Precautionary Statement Wash hands thoroughly after handling. Wear protective gloves/protective clothing/eye protection/face protection.

FIRST AID MEASURES

Eye Contact: Immediately flush eyes with plenty of water for at least 15 to 20 minutes. Ensure adequate flushing of the eyes by separating the eyelids with fingers. Get immediate medical attention.

Skin Contact: Immediately wash skin with plenty of soap and water for 15 to 20 minutes, while removing contaminated clothing and shoes. Get medical attention if irritation develops or persists.

Inhalation: If inhaled, remove to fresh air. If not breathing, give artificial respiration or give oxygen by trained personnel. Seek immediate medical attention.

Ingestion: If swallowed, do NOT induce vomiting. Call a physician or poison control center immediately. Never give anything by mouth to an unconscious person. Store locked up. Dispose of contents/container in accordance with Local, State, Federal and Provincial regulation.

Spills: Collect with suitable absorbent material such as cotton rags.

Disposal: Dispose of in accordance with local, state or federal regulations.

Warning: KEEP CONTAINER CLOSED WHEN NOT IN USE. KEEP OUT OF THE REACH OF CHILDREN. NOT FOR INTERNAL CONSUMPTION. FOR INDUSTRIAL USE ONLY. Consult the Safety Data Sheet (SDS) in the Products section at masterwall.com for further health and safety information.

LIMITED WARRANTY

This product is subject to a written limited material or system warranty. Obtain a warranty from the Tech Support tab of our website. Refer to Specifications for more complete information on proper use and handling of this product.

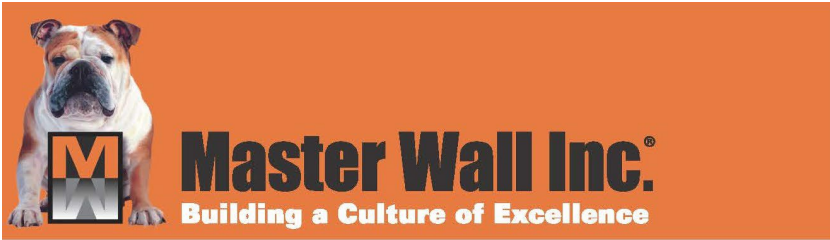

SAMPLE WARRANTY

Master Wall® Light Masonry (LiMa) Program Limited Warranty

LiMa Assemblies LiMaW105, LiMaW205, LiMaM105, LiMaC105: 5 years
LiMa Assemblies LiMaW110, LiMaW210, LiMai310TV, LiMai410CB, LiMai510CB: 10 years
LiMa Assemblies LiMaW120, LiMaM120, LiMaM220, LiMaM320, LiMaM420: 20 years
LiMa Assemblies LiMaC130, LiMaC230: 30 years

Master Wall Inc.® warrants the properly designed and installed Master Wall Inc.® materials for the term noted above from the date of installation over the listed, approved Light Masonry (LiMa) assemblies. Subject to the conditions and limitations stated below, Master Wall Inc.® warrants that the products listed on this document will be free from manufacturing defects and will not break down or deteriorate under normal usage for term stated above from the date of purchase when installed in accordance with the written specifications of Master Wall Inc.® and industry standard guidelines. For this limited warranty to apply, the applications that comprise the installation must be performed with the products listed in this document for each application (LiMa Assemblies). Please refer to individual product data sheets for specific guidelines.

Substrate deflection under all live, dead and impact loads, including concentrated loads, must not exceed $L/360$ where L =span length. Applications must not exceed 30 ft (9.1 m) in height or 25,000 ft² (2,250 m²) in area. Installations must conform to all applicable building codes including the International Building Code (IBC) and International Residential Code (IRC) requirements.

DISCLAIMER

THIS LIMITED WARRANTY IS GIVEN IN LIEU OF ANY OTHER WARRANTY, EXPRESS OR IMPLIED. THERE ARE NO WARRANTIES, EXPRESS OR IMPLIED, INCLUDING WARRANTIES BASED ON SAMPLES OR ORAL STATEMENTS, WHICH EXTEND BEYOND THE DESCRIPTION ON THE FACE OF THIS DOCUMENT. IMPLIED WARRANTIES OF MERCHANTABILITY AND OF FITNESS FOR A PARTICULAR PURPOSE ARE EXCLUDED.

EXCLUSIONS

Master Wall Inc.® is not responsible for workmanship not in accordance with the instructions of Master Wall Inc. and industry standard guidelines. Cracking due to structural movement, excessive deflection or other failure in the substrate is also not covered. Master Wall Inc.® IS NOT LIABLE FOR ANY INCIDENTAL DAMAGES OR CONSEQUENTIAL DAMAGES, INCLUDING LOSSES DUE TO DELAYS, INCURRED BY THE PURCHASER OR ANY OTHER PARTY.

NO ASSIGNMENT

This limited warranty is not transferable or assignable.

EXCLUSIVE REMEDY

The sole and exclusive remedy for a breach of this limited warranty is replacement of only the specific portion of the installation that is proven to be defective*. Master Wall Inc.® will pay for replacement of its own products and replacement of finishing materials, as well as for labor for the replacement installation, but Master Wall Inc. will not pay more, calculated on a square-foot (square-meter) basis, for the replacement than the original purchase price of the portion being replaced. Master Wall Inc.® will not pay for the replacement of any portion of the installation that is not proven to be defective.

In the event that the sole and exclusive remedy described above fails of its essential purpose, the liability of Master Wall Inc.® is limited to the monetary value, on a square-foot (square-meter) basis, of the original purchase price of the portion being replaced.

* NOTE: Efflorescence is a normal condition of Portland cement mortars and is not a defective condition.

This warranty becomes effective only when all bills for the components of the system have been paid.

Except as stated, Master Wall, Inc.®, expressly disclaims any warranty of merchantability or fitness for a particular purpose. The above remedies are to be deemed exclusive.



This is not the final warranty. For a valid warranty fill out a warranty request under Tools and Technical at masterwall.com. Warranties are not valid until issued.

System Detail

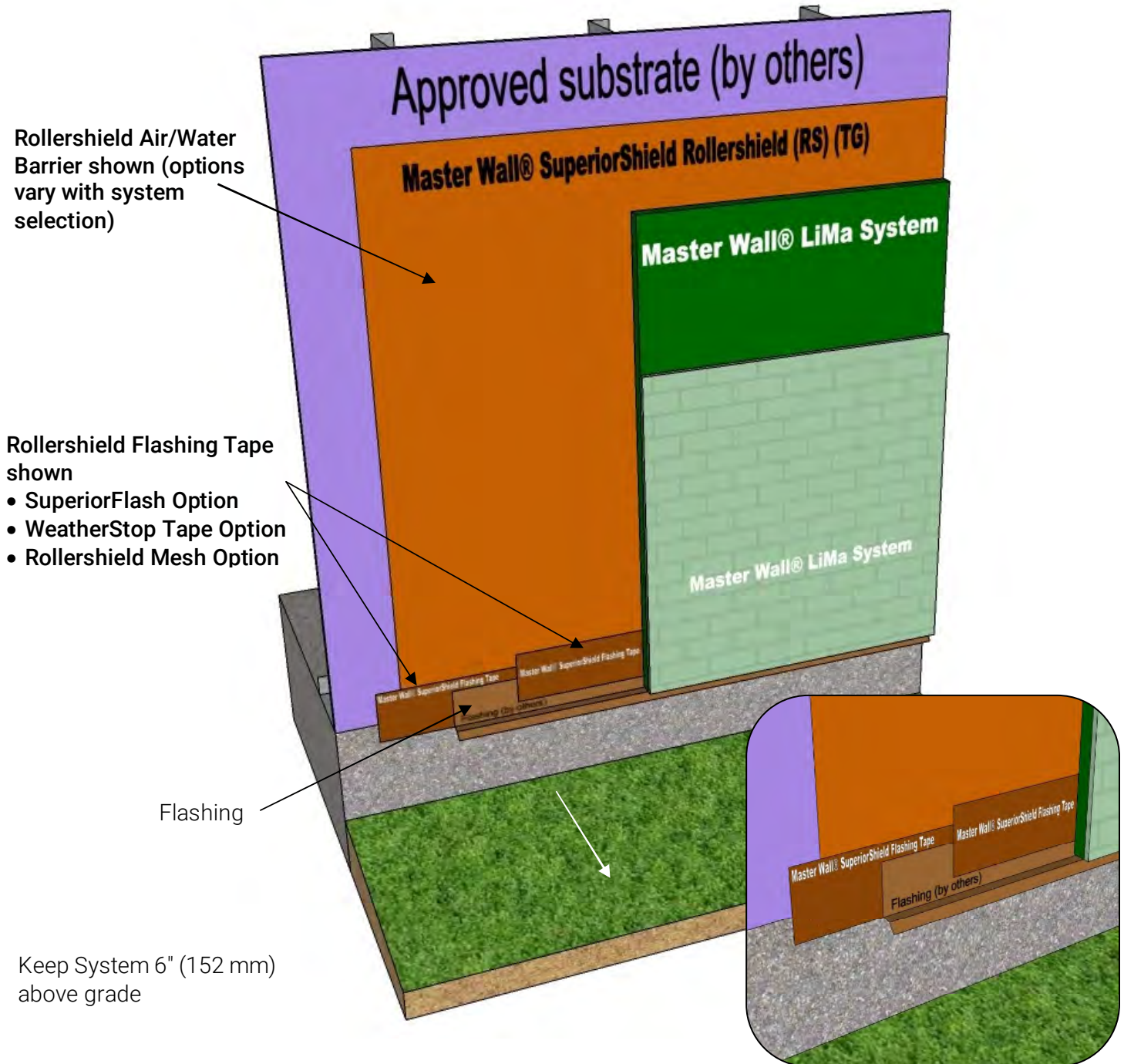

LiMa D-01Detail @ Grade

These drawings relay the conceptual conditions of Master Wall® Systems and are not the construction drawings. Ultimately the design and detailing of an entire wall system is the responsibility of a professional. These details will guide the design professional in the use of Master Wall® Products. Master Wall disclaims design, warranty or construction intent or responsibility. **Bold or Trade Name = Master Wall® Product.** ©2020 Master Wall Inc.®

System Detail

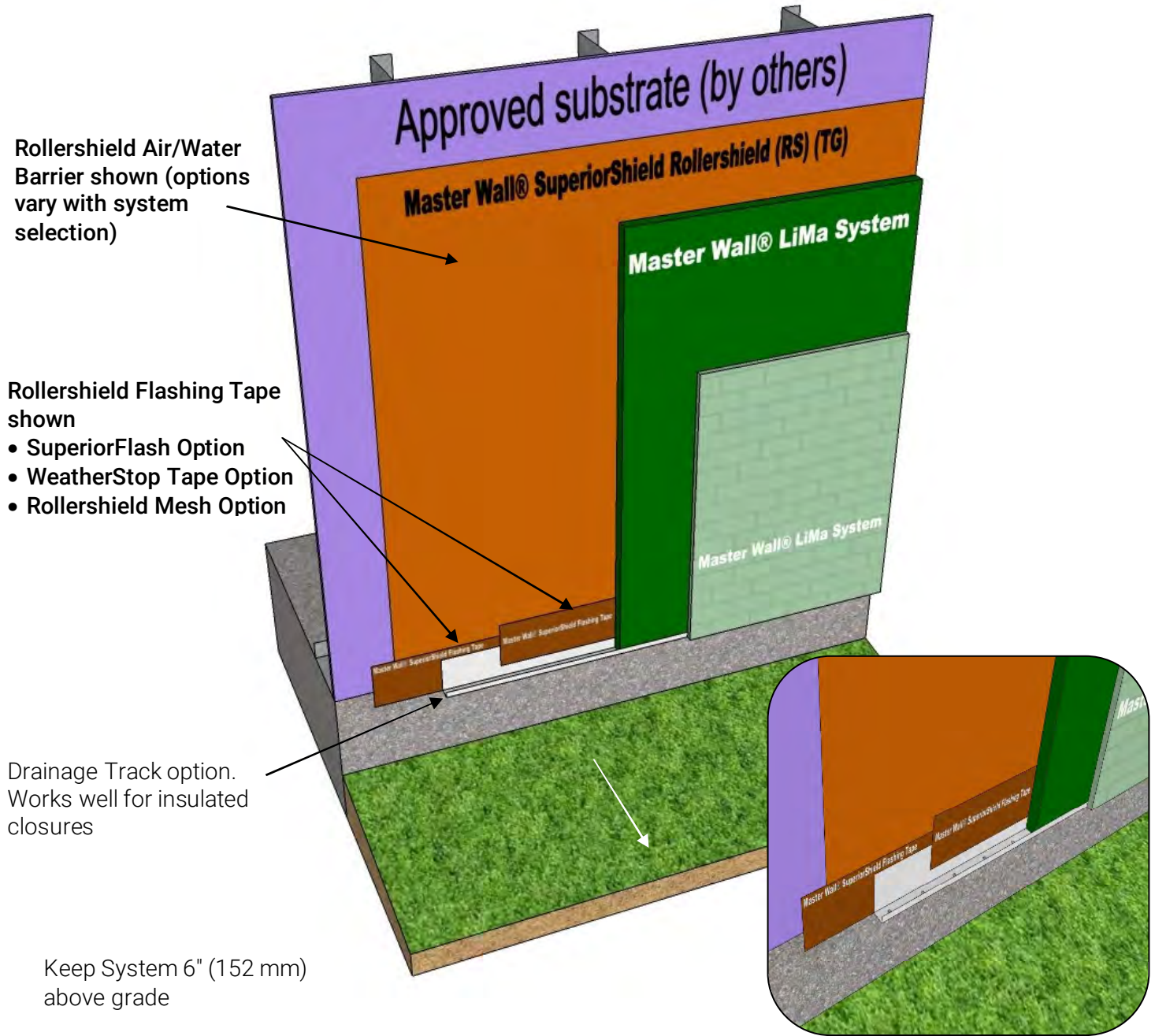

LiMa D-02 Detail @ Grade

These drawings relay the conceptual conditions of Master Wall® Systems and are not the construction drawings. Ultimately the design and detailing of an entire wall system is the responsibility of a professional. These details will guide the design professional in the use of Master Wall® Products. Master Wall disclaims design, warranty or construction intent or responsibility. **Bold or Trade Name = Master Wall® Product.** ©2020 Master Wall Inc.®

System Detail

Rollershield Air/Water Barrier shown (options vary with system selection)

Rollershield Flashing Tape shown

- SuperiorFlash Option
- WeatherStop Tape Option
- Rollershield Mesh Option

Flashing

Keep System 6" (152 mm) above grade

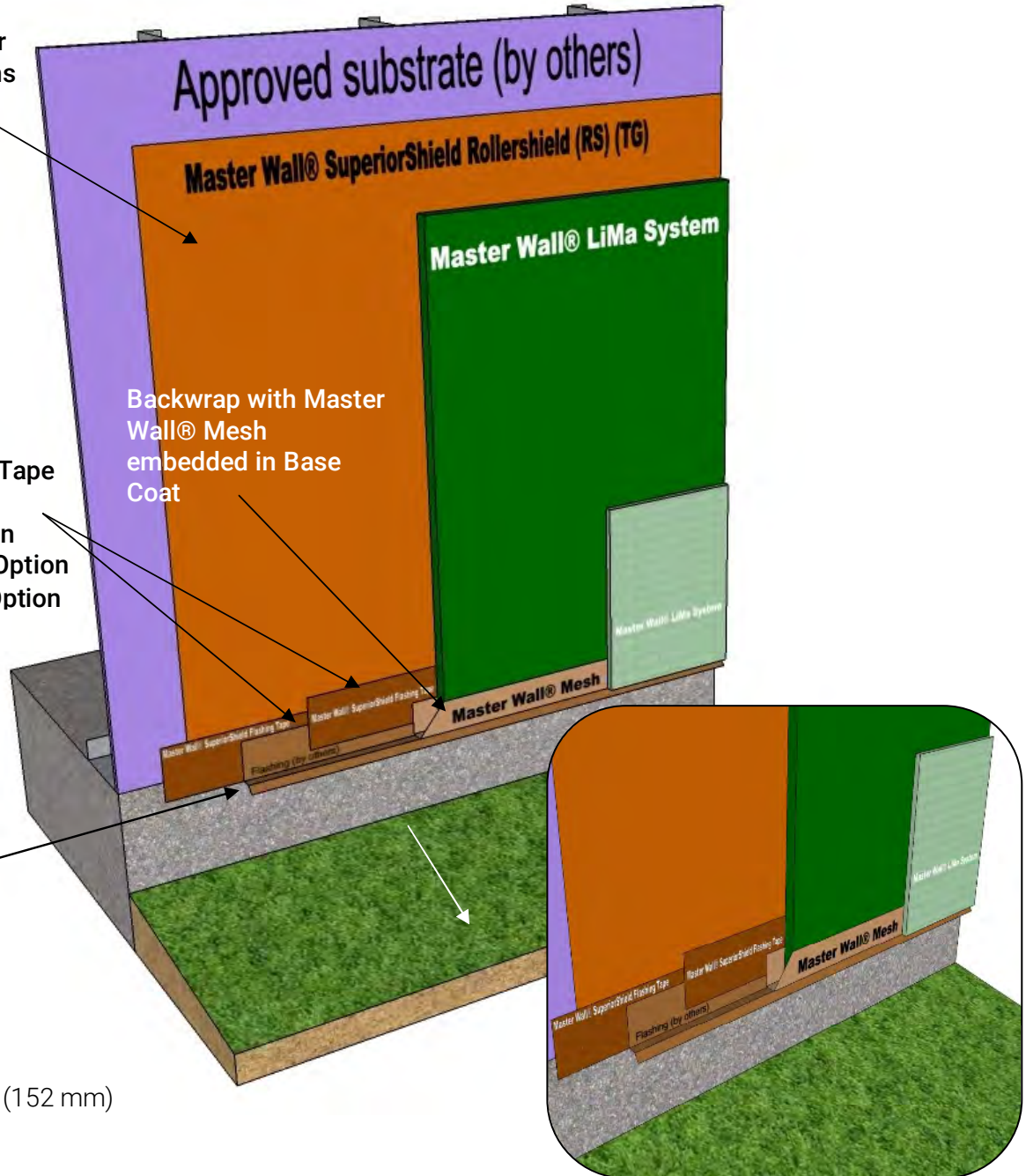

LiMa D-03 Detail @ Grade

These drawings relay the conceptual conditions of Master Wall® Systems and are not the construction drawings. Ultimately the design and detailing of an entire wall system is the responsibility of a professional. These details will guide the design professional in the use of Master Wall® Products. Master Wall disclaims design, warranty or construction intent or responsibility. **Bold or Trade Name = Master Wall® Product.**

System Detail

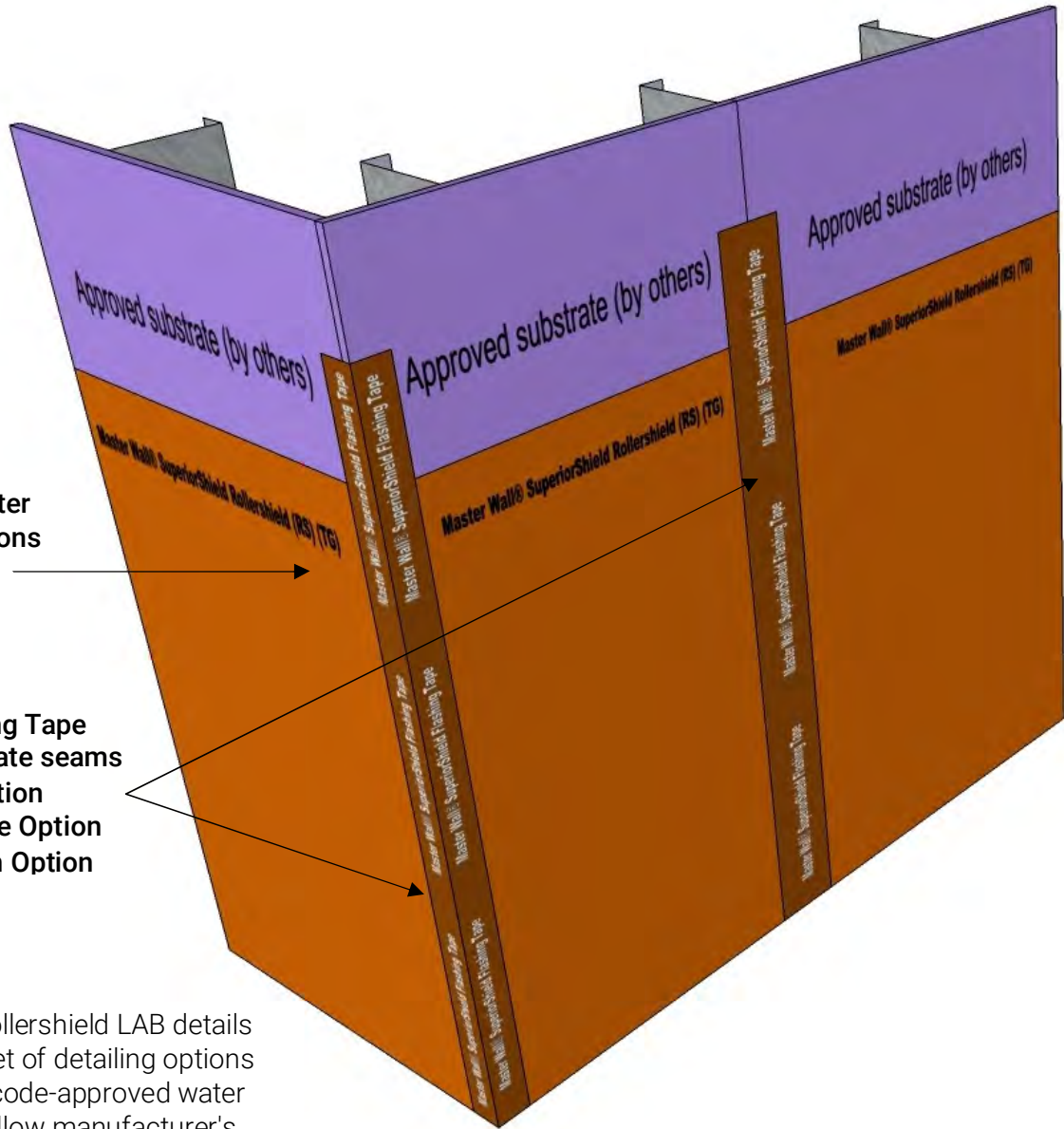

Rollershield Air/Water Barrier shown (options vary with system selection)

Rollershield Flashing Tape shown @ all substrate seams

- SuperiorFlash Option
- WeatherStop Tape Option
- Rollershield Mesh Option

Notes:

- See the Rollershield LAB details for a full set of detailing options
- For other code-approved water barriers follow manufacturer's instructions

LiMa D-04 Rollershield LAB Seam Details

These drawings relay the conceptual conditions of Master Wall® Systems and are not the construction drawings. Ultimately the design and detailing of an entire wall system is the responsibility of a professional. These details will guide the design professional in the use of Master Wall® Products. Master Wall disclaims design, warranty or construction intent or responsibility. **Bold or Trade Name = Master Wall® Product.**

System Detail



Rollershield Air/Water Barrier shown (options vary with system selection)

Rollershield Flashing Tape shown @ all substrate seams and turned into window opening at least the depth of the window unit

- SuperiorFlash Option
- WeatherStop Tape Option
- Rollershield Mesh Option

Rollershield Flashing Tape shown adhered over flashing

Window Head Flashing



Diagonal Rollershield Flashing Tape shown

- SuperiorFlash Option
- WeatherStop Tape Option
- Rollershield Mesh Option

Notes:

- See the Rollershield LAB details for a full set of detailing options
- For other code-approved water barriers follow manufacturer's instructions

LiMa D-05 Window Opening

These drawings relay the conceptual conditions of Master Wall® Systems and are not the construction drawings. Ultimately the design and detailing of an entire wall system is the responsibility of a professional. These details will guide the design professional in the use of Master Wall® Products. Master Wall disclaims design, warranty or construction intent or responsibility. **Bold or Trade Name = Master Wall® Product.**

System Detail

Rollershield Air/Water Barrier shown
(options vary with system selection)

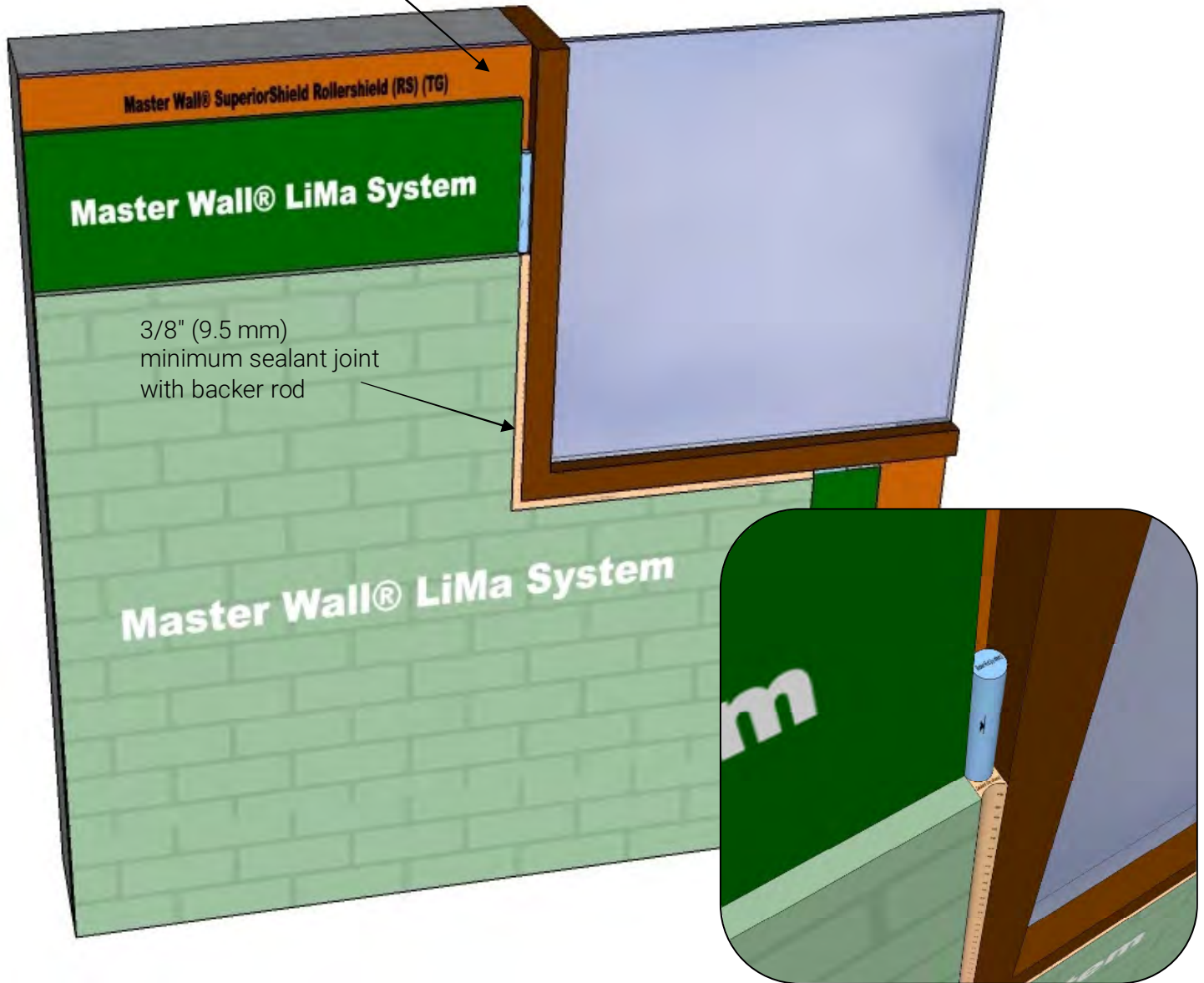

LiMa D-06 LiMa to Window Detail

These drawings relay the conceptual conditions of Master Wall® Systems and are not the construction drawings. Ultimately the design and detailing of an entire wall system is the responsibility of a professional. These details will guide the design professional in the use of Master Wall® Products. Master Wall disclaims design, warranty or construction intent or responsibility. **Bold or Trade Name = Master Wall® Product.**

©2020 Master Wall Inc.®

System Detail

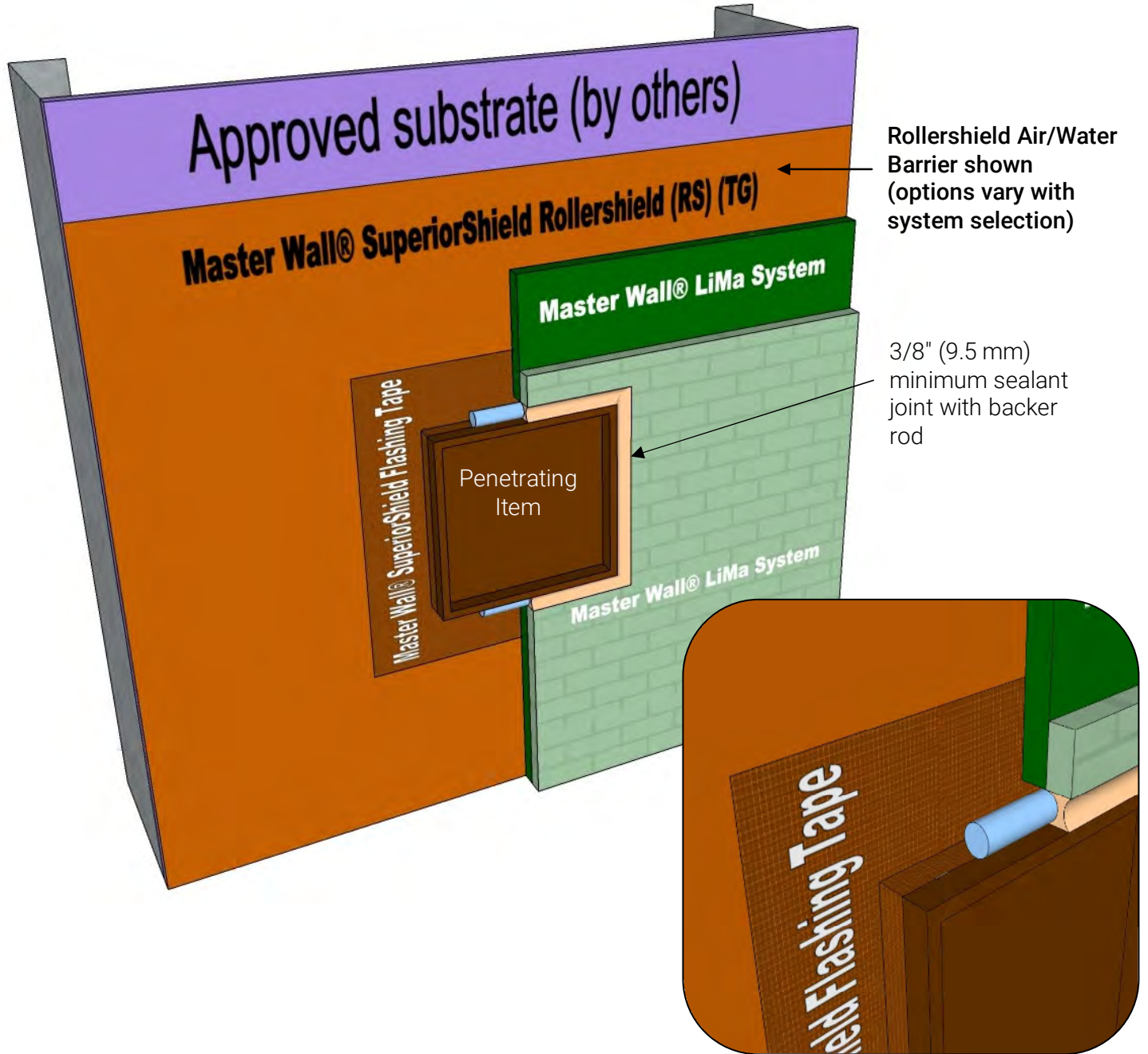

LiMa D-07 LiMa to Wall Penetration Detail

These drawings relay the conceptual conditions of Master Wall® Systems and are not the construction drawings. Ultimately the design and detailing of an entire wall system is the responsibility of a professional. These details will guide the design professional in the use of Master Wall® Products. Master Wall disclaims design, warranty or construction intent or responsibility. **Bold or Trade Name = Master Wall® Product.** ©2020 Master Wall Inc.®

System Detail

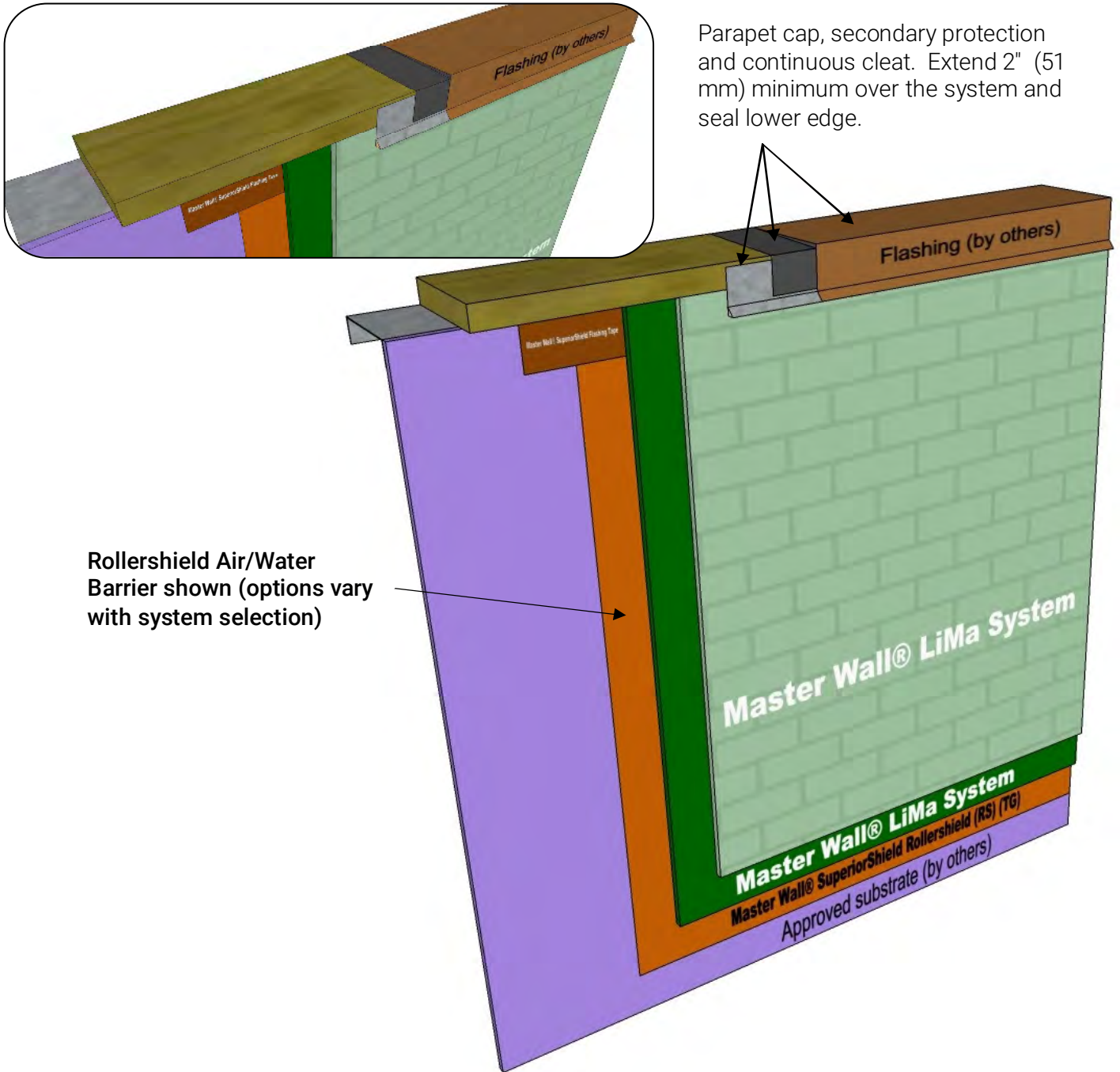

LiMa D-08 Parapet Cap Detail

These drawings relay the conceptual conditions of Master Wall® Systems and are not the construction drawings. Ultimately the design and detailing of an entire wall system is the responsibility of a professional. These details will guide the design professional in the use of Master Wall® Products. Master Wall disclaims design, warranty or construction intent or responsibility. **Bold or Trade Name = Master Wall® Product.**

System Detail

WeatherStop Tape shown @ substrate expansion joint

- Rollershield with Rollershield Flashing Tape and backing
- SuperiorFlash with backing Option

Rollershield Air/Water Barrier shown (options vary with system selection)

Sealant joint and backer rod sized for anticipated movement, 3/8" (9.5 mm) minimum

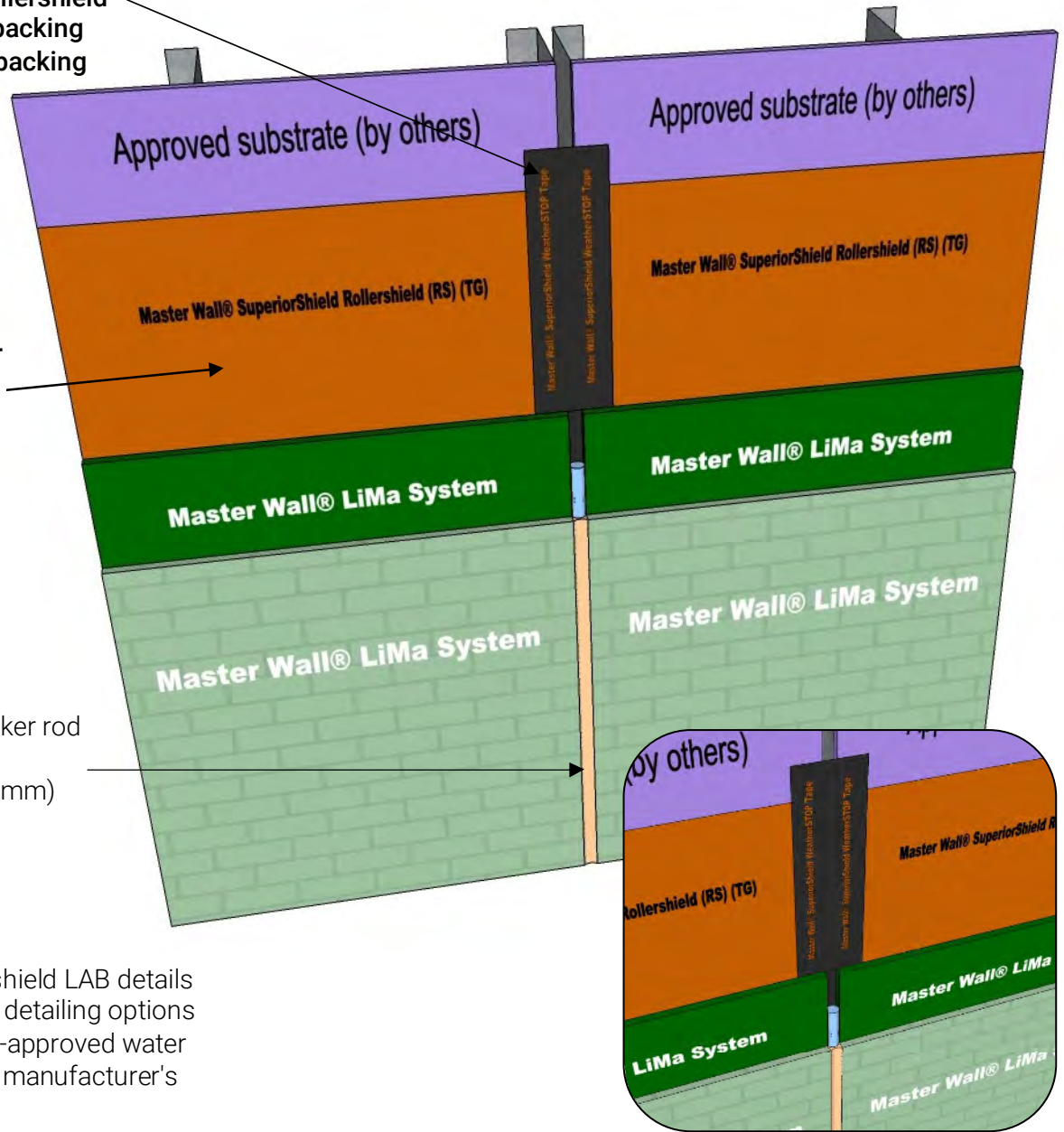

Notes:

- See the Rollershield LAB details for a full set of detailing options
- For other code-approved water barriers follow manufacturer's instructions

LiMa D-09 Expansion Joint Detail

These drawings relay the conceptual conditions of Master Wall® Systems and are not the construction drawings. Ultimately the design and detailing of an entire wall system is the responsibility of a professional. These details will guide the design professional in the use of Master Wall® Products. Master Wall disclaims design, warranty or construction intent or responsibility. **Bold or Trade Name = Master Wall® Product.**

System Detail

Rollershield Air/Water Barrier shown (options vary with system selection)

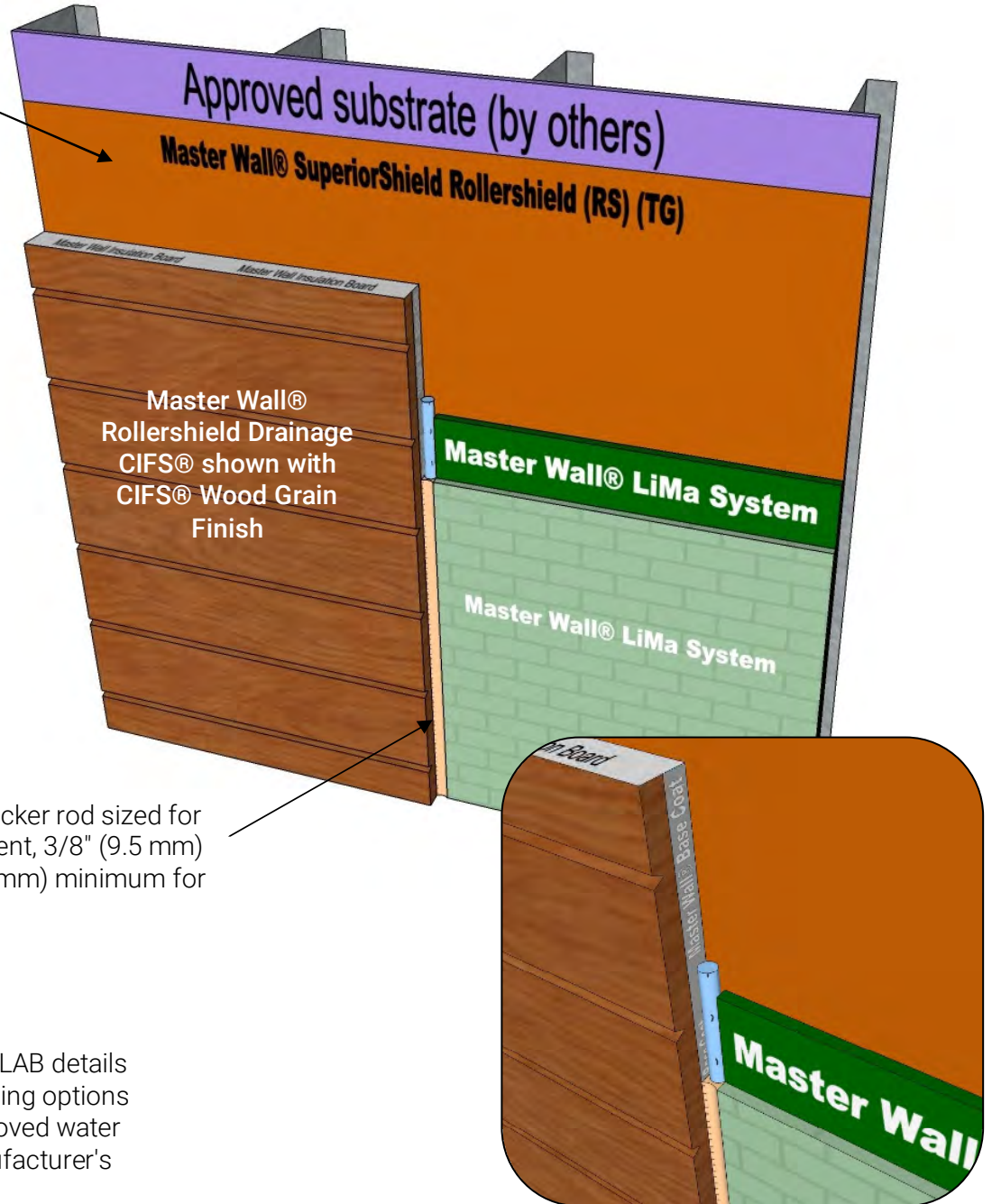

Notes:

- See the Rollershield LAB details for a full set of detailing options
- For other code-approved water barriers follow manufacturer's instructions

LiMa D-10 Dissimilar Materials

These drawings relay the conceptual conditions of Master Wall® Systems and are not the construction drawings. Ultimately the design and detailing of an entire wall system is the responsibility of a professional. These details will guide the design professional in the use of Master Wall® Products. Master Wall disclaims design, warranty or construction intent or responsibility. **Bold or Trade Name = Master Wall® Product.**