

Project Submittal Package



Project:

Location:

Architect:

General Contractor:

Applicator:



Master Wall Inc.®



[System Data Sheets](#) [Product Data Sheets](#) [Sample Warranty](#)

[Specifications](#) [Details](#) [Web Link \(click here\)](#)

PO Box 397

Fortson

GA

31808

800-755-0825

masterwall.com

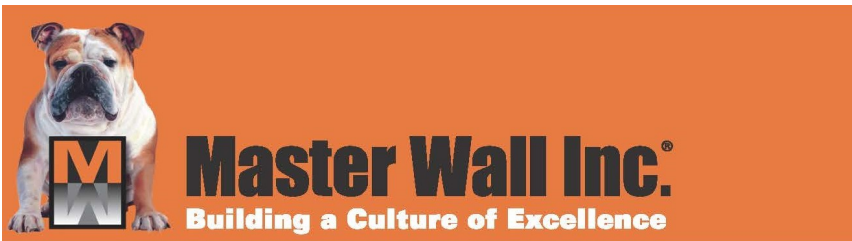

SUPERIORSHIELD ROLLERSHIELD LAB SYSTEM

Liquid-applied Air/Water Barrier

SuperiorShield Rollershield LAB Liquid-applied Air/Water Barrier system is a series of products for use with claddings other than EIFS that delivers a durable, robust high-performance air and water barrier that is easily applied yet comparatively less expensive than other fluid or peel and stick barriers.

The system offers 100% protection for building walls over all common substrates (Glass Fiber Sheathing, concrete, masonry, plywood, OSB) with no laps, breaks or holes. Window and door openings are flashed as are penetrations

Primary LAB Wall Components

- Rollershield RS (Roll/Spray) – Vapor open with thin to thick application methods to suit project needs
- Rollershield TG (Trowel Grade) – Vapor open trowel grade version of RS
- Rollershield VB (Vapor Barrier) – Vapor closed; roll/spray applied
- Rollershield B (Black) – Darker version of Rollershield RS for use with screen wall applications where it may be visible.

Seaming & Secondary Flashing Options

- SuperiorShield Flashing Tape – Seaming and transition tape embedded in Rollershield products
- SuperiorFlash – STPE seaming and flashing product option that speeds the application process
- SuperiorShield SMP Sealant - Silyl Modified Polyether seaming option

Features & Benefits

- Weather protection as thin as 10 mils
- Seamless with no laps
- Medium to high build options
- Vapor open or closed options
- Screen wall options
- Seaming and flashing options
- Single source warranty options with Master Wall® CIFS® and other systems

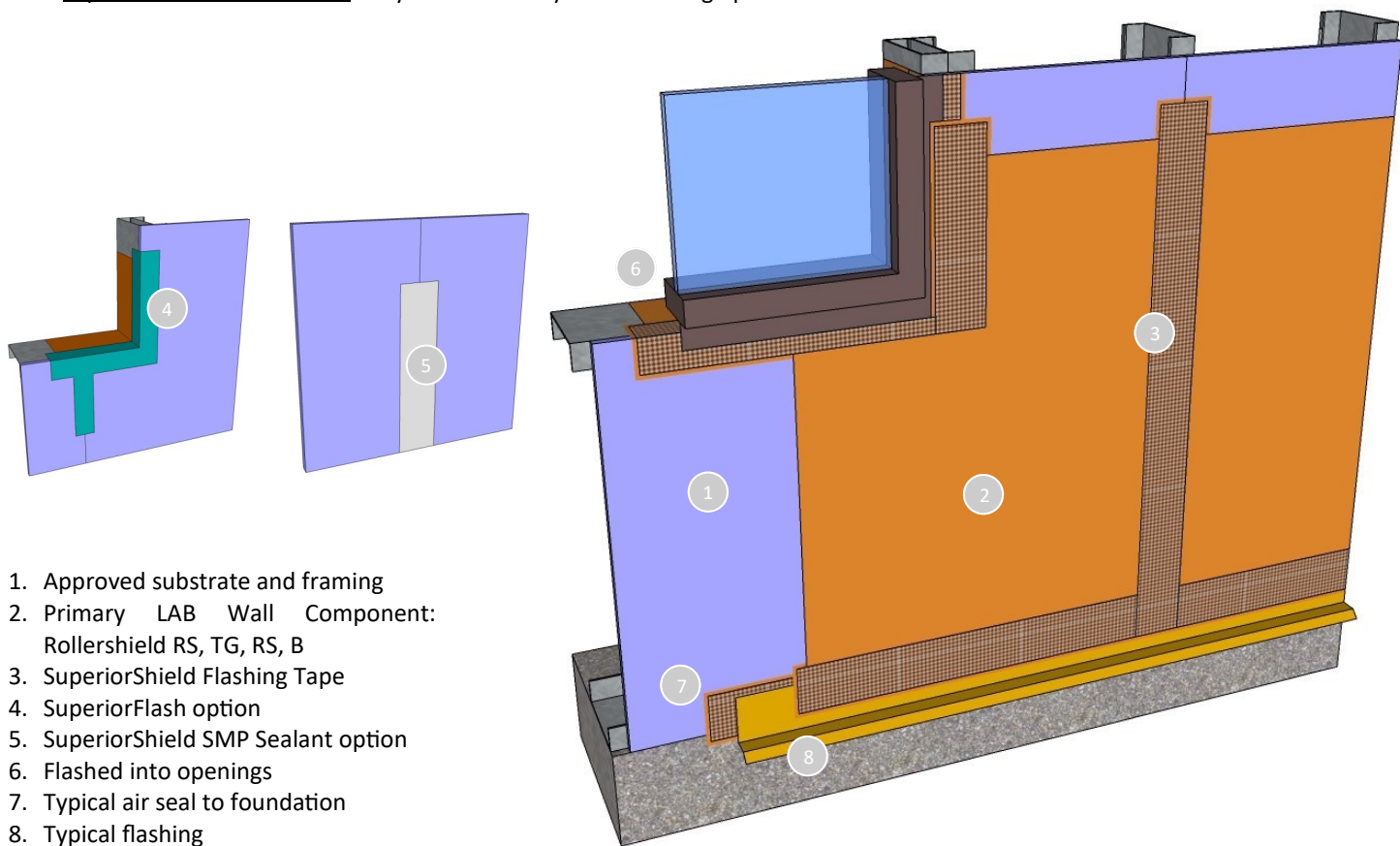

1. Approved substrate and framing
2. Primary LAB Wall Component: Rollershield RS, TG, RS, B
3. SuperiorShield Flashing Tape
4. SuperiorFlash option
5. SuperiorShield SMP Sealant option
6. Flashed into openings
7. Typical air seal to foundation
8. Typical flashing

Short Form Specification**1.0 General**

This is a short form specification. Refer to Rollershield LAB specifications and details for additional information.

1.1 System Description

The Master Wall Inc.® SuperiorShield Rollershield LAB System is a liquid applied air and water barrier.

1.2 Design Requirements:

- A. Reference Master Wall® suggested details and architectural drawings for specific detail requirements.
- B. Maximum deflection of substrates shall not exceed L/240.
- C. Typical acceptable substrates include unpainted brick, masonry, concrete, plywood, Oriented Strand Board (OSB) or gypsum sheathings (ASTM C1396 or C1177). Contact Master Wall® for other approved substrates.

1.3 Job Conditions

- A. Store all materials protected from weather and direct sunlight at temperatures above 40°F (5°C).
- B. The ambient and wall temperature shall be a minimum of 40°F (5°C) and shall remain so for at least 24 hours after installation, except for specific products.

2.0 Products

All components of the Rollershield System shall be manufactured by Master Wall Inc.® and supplied by an authorized distributor.

A. Water Barrier:

1. Rollershield RS (Roll/Spray) – Vapor open air/water barrier
2. Rollershield TG (Trowel Grade) – Vapor open trowel grade version
3. Rollershield VB (Vapor Barrier) – Vapor closed air/water barrier
4. Rollershield B (Black) – Darker version of Rollershield RS

B. Seaming and Flashing

1. SuperiorShield Flashing Tape: A lightweight nonwoven joint treatment material.
2. SuperiorFlash – STPE seaming and flashing product
3. SuperiorShield SMP Sealant - Silyl Modified Polyether seaming product

3.0 Installation

- A. Inspect the substrate to ensure that it is free of all foreign materials that would affect the adhesion of the Rollershield LAB.
- B. Apply the coatings in strict accordance with Master Wall® specifications, product data sheets, architectural drawings and architectural specifications.

Compliance Standards

System complies with 2012-2011 IBC and IRC per IAPMO ER-0384, Tensile Bond ASTM C297/E2134 – min. 28 psi, Freeze-thaw ASTM E2485 – pass, Water Resistance ASTM D2247 – pass, Water Vapor Transmission ASTM E96 Proc. B - Rollershield RS/B (30 perms) Rollershield TG (12 perms) Rollershield VB (0.07/1.35 perms), Air Permeance ASTM E2178 - 0.001 cfm/ft² @ 1.57 psf (0.001 L/s/m² @ 75 Pa), Air Leakage ASTM E2357 - 0.0006 cfm/ft² @ 1.57 psf (0.003 L/s/m² @ 75 Pa) & 0.04 cfm/ft² @ 6.24 psf (0.02 L/s/m² @ 300 Pa), Structural Performance ASTM E1233 – pass, ASTM E72 – pass, Restrained Environmental ICC-ES Procedure – pass, Water Penetration ASTM E331 – pass, UV Exposure – pass, Accelerated Aging – pass, Hydrostatic Pressure Test AATCC 127 – pass, Surface Burning Characteristics ASTM E84 – pass, Intermediate Multi-Story Fire Test NFPA 285 – pass, Nail Sealability ASTM D1970 – pass, Heat and Smoke Release Rates ASTM E1354 – pass, ICC-ES AC212 - pass

Information contained in this product data sheet conforms to the standard detail recommendations and specifications for the installation of Master Wall Inc.® products and is presented in good faith. Master Wall Inc.® assumes no liability, expressed or implied as to the architecture, engineering, or workmanship of any project. This information may be concurrent with, or superseded by other applicable documents, such as specifications and details. Contact Master Wall Inc.® for the most current product information. ©2024 Master Wall Inc.®





PRODUCT DATA

SUPERIORSHIELD ROLLERSHIELD VB

SuperiorShield Rollershield VB is the vapor barrier version of our Rollershield Liquid applied Air/Water Barrier (LAB). Rollershield VB is a high quality roll applied flexible air and water barrier. Easily applied with a trowel, brush, roller, hopper gun or airless sprayer. Rollershield VB forms a continuous air, water, and vapor barrier that protects approved substrates from incidental water damage.

FEATURES & BENEFITS

- 100% Coverage
- Class I Vapor Retarder
- Vapor impermeable, 0.07 perms
- Doesn't rattle in the wind
- Used as water barrier and flashing
- Compatible with Rollershield-RS, Rollershield-TG, SuperiorFlash and WeatherSTOP Tape (also Vapor Impermeable)
- Adheres to most common building materials
- Easy to apply, water based for easy cleanup
- Low VOC

Application Temperature: 40°-110°F (5°-43°C) Dry to Touch: 1 hr. Re-coat Time: 2 hrs. Dry Time: 12 hrs. at room temperature, working and drying time will vary with temperature and humidity.

JOB CONDITIONS

Air and substrate temperature for application of Rollershield VB must be 40°F (5°C) or higher and must remain 40°F (5°C) or higher for a minimum of 24 hours. Provide temporary protection to protect the wall system from damage until permanent flashings, caps and sealants are installed. Store materials within prescribed temperature limits and out of direct sunlight. Working and drying times are based upon normal room temperature conditions and will vary with temperature and humidity.

PREPARATION

The substrate must be approved by Master Wall Inc., clean, dry, structurally sound and free of efflorescence, oil, grease, form release agents and curing compounds or anything that would affect bond. Painted surfaces are not acceptable and must be removed. Substrates must be flat and free of fins or planar irregularities greater than 1/4" in 10'-0" (6.35 mm in 3.05 m).

Coverage per pail (sf/m²)*

Roller: 225-250 (21-23)
Trowel: 100-125 (9-11.6)
Spray: 150-175 (14-16)

**2-coat coverage @ 20 mil dry thickness. All coverage is approximate and depend upon substrate, details and individual application*

Packaging/Shelf Life/Storage

Packaging: 5 gallon (19 L) pail

Shelf Life: 2 years

Storage: Protect from extreme heat - 90°F (32°C), freezing and direct sunlight.

Technical Data

Tensile Bond, ASTM C297/E2134/AC212: 30-200 psi

Freeze-thaw ASTM E2485/AC212: Pass

Water Resistance, ASTM D2247/AC212: Pass

Water Vapor Transmission, ASTM E96 Proc. B/AC212: 5 perms

Air Permeance, ASTM E2178: 0.001 cfm/ft² @ 1.57 psf, 0.001 L/s/m² @ 75 Pa

Air Leakage, ASTM E2357: 0.0006 cfm/ft² @ 1.57 psf (0.003 L/s/m² @ 75 Pa), 0.04 cfm/ft² @ 6.24 psf (0.02 L/s/m² @ 300 Pa)

Structural Performance, ASTM E1233/AC212: Pass

Racking, ASTM E72/AC212: Pass

Restrained Environmental, AC212: Pass

Water Penetration, ASTM E331/AC212: Pass

UV Exposure: Rated to 6 months

Accelerated Aging, AC212: Pass

Hydrostatic Pressure Test, AATCC 127/AC212: Pass

Nail Sealability, ASTM D1970: Pass

APPLICATION PROCEDURE

Concrete – Must have cured a minimum of 28 days prior to the application of Rollershield VB. If form release agents or curing compounds exist on the surface, they must be removed with a solution of muriatic acid or similar product (with appropriate precautions). Remove any residual acid by flushing with water.

Brick/Masonry – If joints are not struck flush, multiple coats may be required. Contact Master Wall for more information.

Sheathing Applications - Sheathing gaps must be less than 1/4" (6.4 mm). For gaps larger than 1/4" (6.4 mm) WeatherSTOP Tape or Rollershield Flashing Tape may be used. Gap wood-based sheathing per manufacturers recommendations, typically 1/8" (3.2 mm) minimum.

Mixing - Thoroughly stir Rollershield VB into a homogenous consistency. Do not add water, over mix, or add accelerators or retarders to Rollershield VB.

Application – Rollershield VB is applied by first treating the joints and fastener locations where sheathing is used, then coating the entire surface with 2-coats of 15-mils wet (10 mils dry) using brush, roller, trowel or airless spray equipment techniques. When using a foam roller, a maximum 3/4" (19 mm) nap is recommended. Apply Rollershield VB in an even, continuous coat, maintaining a wet edge of approximately 15 mils thickness. For moisture protection, Rollershield VB must be applied as a continuous barrier of 20 mils dry thickness with no breaks or skips, although some areas will appear lighter than others due to the application process. The Rollershield VB application need not look like a painted surface.

Joint Treatment—Apply a thin layer of Rollershield VB to the joints and embed SuperiorShield Flashing Tape into the wet mixture and trowel smooth.

Rollershield VB may be flashed into window, door and other openings using the same techniques for sheathing applications. Any remaining gaps should be filled with Rollershield VB and Flashing Tape.

Wall Treatment—Apply Rollershield VB to the wall surface using the foam roller, trowel or by spray applying and backrolling to a uniform thickness of 20 mils with no pinholes or voids.

Clean Up—Tools and equipment can be cleaned with soapy water when Rollershield VB is wet.

Limitations

Not for use as an exterior finish, note exposure limitations on front page.

When adhering Rollershield Drainage CIFS® to the surface assure it is clean, dry and free of surface contamination. Remove any dirt or surface contamination before adhesive attachment.

Allowable in-service temperature range: -40° to 180°F (-40° to 82°C).

Fire-retardant or pressure treated plywood must be dry with surface free of salts or other chemicals migrating from within the wood. Test adhesion to be sure of desired results.

Use a slip sheet, typically one layer of building paper between Rollershield-B and stucco or adhered masonry veneer over metal lath.

Spray Application

Rollershield VB is compatible with GRACO and Titan airless spray equipment with the following specifications:

- Minimum 1 gallon per minute output.
- Minimum hose width of 3/8 inch.
- Minimum tip size of 0.027–0.031.

Minimum pressure requirement to spray of 2,000 psi at the gun with an airless sprayer rated no lower than 3,300 psi. Remove all filters in sprayer and gun before application.

Hopper Gun: 3/16"-1/4" (6-6.5 mm) orifice, 23-25 psi.

Information contained in this product data sheet conforms to the standard detail recommendations and specifications for the installation of Master Wall Inc.® products and is presented in good faith. Master Wall Inc.® assumes no liability, expressed or implied as to the architecture, engineering, or workmanship of any project. This information may be concurrent with, or superseded by other applicable documents, such as specifications



Hazard: This chemical is not considered hazardous according to the OSHA Hazard Communication Standard 2012 (29 CFR 1910.1200).

VOC: Less than 50 g/L.

Approved Substrates

Exterior gypsum sheathing (ASTM C1396)

Glass Fiber Exterior Sheathing (ASTM C1177): Dens Glass Gold®, GlasRoc®, FiberBond®, Gold Bond e2xp®, etc.

Cement Board Substrates (ASTM C1325): Durock®, PermaBase®, ProTEC®, SelectCrete, Util-A-Crete®, etc.

Concrete

Brick

Masonry

Exterior Plywood

Oriented Strand Board (OSB)

Huber Zip (See Data Sheet for Specifics)

Most metals and PVC

Others approved in writing

Sealant Bond Compatibility**

Master Wall: SuperiorShield SMP

Adfast Corp.: Adseal DWSP1940 Series***, Adseal 4600, Adseal 4580, Adseal 1940

Dow Corning: 795 Silicone**

Pecora Corp.: 864NST, 890NST, 890FTS, 895NSTA, Dynatrol I-XL HybridB

Sika: Silaflex 15 LM***, Silaflex-2C NS*** Master Builders Solutions:

MasterSeal NP1*** Tremco: Dymonic 100***

Most polyurethane sealants**

See Technical Bulletin MW#131 for latest sealant information

**field verify bond (varies)

***Also bonds to SuperiorFlash

^AWith P120 Primer with Rollershield RS & VB

^BWith P120 Primer with Rollershield VB

Warning: KEEP CONTAINER CLOSED WHEN NOT IN USE. KEEP OUT OF THE REACH OF CHILDREN. NOT FOR INTERNAL CONSUMPTION. FOR INDUSTRIAL USE ONLY. Consult the Safety Data Sheet (SDS) in the Products section at masterwall.com for further health and safety information.

LIMITED WARRANTY

This product is subject to a written limited material or system warranty. Obtain a warranty from the Tech Support tab of our website. Refer to Specifications for more complete information on proper use and handling of this product.



Master Wall Inc.
Building a Culture of Excellence

PRODUCT DATA

SUPERIORSHIELD FLASHING TAPE

Lightweight non adhesive roll flashing material with superior strength and the ability to bridge most gaps or voids common in construction. Embedded into wet Rollershield-RS, TG or VB, it is used at flashing transitions with Master Wall® SuperiorShield Liquid Air/Water Barrier (LAB) and as part of Rollershield Drainage CIFS® applications. The tape easily embeds into wet Rollershield and dries to a highly reinforced yet flexible flashing.

FEATURES & BENEFITS

- Lightweight
- Strong
- Embeds easily
- Thin, will not build up wall surface
- Compatible with Rollershield RS, TG, VB and SuperiorFlash products

JOB CONDITIONS

Air and substrate temperature for application of SuperiorShield Flashing Tape must be 40°F (5°C) or higher. Follow Rollershield-RS, TG or VB temperatures and condition requirements.

PREPARATION

General—The substrate must be clean, dry, structurally sound, and free of efflorescence, oil, grease, form release agents and curing compounds. Test painted surfaces to verify bond.

Temporary Protection – Protect from weather until the Rollershield-RS, TG or VB products have set up.

Surface Preparation - Surface temperature must be above 40°F (5°C). Surface must be cured, clean, dry, structurally sound, and free of efflorescence, oil, grease, form release agents, and curing compounds.

Coverage estimate*

4x8 sheets: Square Footage x 0.37 = linear feet of tape

Add linear footage around windows, doors, and other openings.

**All coverage is approximate and depend upon substrate, details and individual application*

Roll Sizing/Packaging/Shelf Life/Storage

4"x180' (10.2cm x 54.9m)

6"x180' (15.2cm x 54.9m)

9"x180' (22.9cm x 54.9m)

Packaging:

4": 18 rolls per case.

6" & 9": 12 rolls per case.

Shelf Life: 2 years plus

Storage: Protect from extreme heat (90°F (32°C)), and direct sunlight.

APPLICATION PROCEDURE

General - SuperiorShield Flashing Tape is embedded into wet Rollershield-RS, TG or VB at flashing transitions (sheathing to framing, flashing, penetrations, etc.) and at sheathing board joints. Apply a generous layer of the product using a trowel, brush or roller and immediately embed the SuperiorShield Flashing Tape into the product and draw it tight and smooth working from the center to the edges.

Windows – The unique properties of the SuperiorShield air/water barrier system allows window flashing prior to the Rollershield wall application. Apply Rollershield and center SuperiorFlash Flashing Tape to provide at least at least 1” (25 mm) bond to the window flange and substrate on either side of the window opening. Use a “butterfly” at corners to complete the application making sure it covers all corner joints. For best results make sure the Rollershield covers the entire head, jamb, and sill areas. The use of sill wedges or water stops is encouraged.

Sheathing Applications – Apply Rollershield at least 2” (51 mm) either side of the sheathing board joint. Immediately embed the SuperiorShield Flashing Tape into the wet Rollershield and smooth with a trowel, centering it over the joint. Provide at least at least 1” (25 mm) bond either side of the sheathing joint. Lap Rollershield Mesh Tape 2” (51 mm) minimum Rollershield field application can begin as soon as the Rollershield is dry to the touch.

Information contained in this product data sheet conforms to the standard detail recommendations and specifications for the installation of Master Wall Inc.® products and is presented in good faith. Master Wall Inc.® assumes no liability, expressed or implied as to the architecture, engineering, or workmanship of any project. This information may be concurrent with, or superseded by other applicable documents, such as specifications and details. Contact Master Wall Inc.® for the most current product information. ©2022 Master Wall Inc.®



Hazard: This chemical is not considered hazardous according to the OSHA Hazard Communication Standard 2012 (29 CFR 1910.1200).

VOC: Less than 50 g/L.

Approved Materials for Embedment

Rollershield-RS
Rollershield-TG
Rollershield-VB
Others approved in writing

LIMITED WARRANTY

This product is subject to a written limited material or system warranty. Obtain a warranty from the Tech Support tab of our website. Refer to Specifications for more complete information on proper use and handling of this product.

220701



Master Wall Inc.
Building a Culture of Excellence

SAMPLE
WARRANTY

SuperiorShield Rollershield Liquid Applied Barrier

5 Year Labor & Material Limited Warranty

Master Wall Inc.® warrants the properly designed and installed Rollershield Liquid Applied Air/Water Barrier and materials for 5 years from the date of installation. Master Wall Inc.'s exclusive liability under this warranty is to supply replacement materials and labor or corrective procedures, if it is shown that the materials supplied by Master Wall Inc., were defective when installed by the Master Wall Inc. certified applicator. Remedies shall be solely determined by Master Wall Inc. and no other warranties are expressed or implied. For a valid warranty, the system and products must be installed in accordance with Master Wall Inc.'s written recommendations, specifications, details, bulletins and other project-specific written recommendations. Master Wall Inc. must be notified in writing within 10 business days of the original discovery of the defect.

Master Wall Inc. is not responsible for structural conditions, design conditions beyond those noted in our literature, architecture, engineering or workmanship of any project. Drainage Systems are warranted to drain incidental water for the warranty period. Materials must be properly stored and applied in a timely manner. Workmanship, aesthetics and installation are beyond the scope of this warranty as are any deviations from Master Wall Inc. Documents not specifically approved in writing.

Abuse, misuse, excessive weather or environmental conditions beyond what the products or systems have been tested, designed or approved for is expressly limited. Certain colors with organic pigments are less fade-resistant than others. The building, system and products must be properly maintained in accordance with Master Wall Inc., documents, local environmental conditions and good building practices. In no case is Master Wall Inc. responsible for incidental and consequential damages.

This warranty becomes effective only when all bills for the components of the system have been paid.

Except as stated, Master Wall, Inc., expressly disclaims any warranty of merchantability or fitness for a particular purpose. The above remedies are to be deemed exclusive.



Master Wall Inc.
Building a Culture of Excellence

This is not the final warranty. For a valid warranty fill out a warranty request under Tools and Technical at masterwall.com. Warranties are not valid until issued.

PRODUCT AND SYSTEM TESTING



Master Wall Inc.
Building a Culture of Excellence



MASTER WALL® SYSTEMS SPECIFICATION FACT SHEET

- Manufacturer of EIFS, Stucco and Coatings since 1987
- Committed and focused specifically on our industry; privately held and American owned.
- Pioneer in CIFS® (Continuous Insulation and Finish Systems)
- Leader in specialty finishes; CIFS® Wood Grain, CIFS® Brick, Hydrophobic Finishes, Metallics, SuperiorCote coatings
- AWCI Certified EIFS Professional (CEP) accredited Sales and Technical Force
- AIA MasterSpec listed, AIA CES Registered Provider
- Industry Leadership
 - EIMA (EIFS Industry Members Association) – Manufacturer Member and Current President
 - NOCSA (National One Coat Stucco Association) – Manufacturer Member and Current President
 - SMA (Stucco Manufacturer's Association) – Manufacturer Member and Board Member
 - ABAA (Air Barrier Association of America) – Manufacturer Member
 - AWCI (Association of the Wall and Ceiling Industry) – Member
 - FWCCA (Florida Wall & Ceiling Contractors Association) – Member
- Code Compliant EIFS, CIFS® Stucco and Air Barrier Systems (ICC, Miami Dade and Florida Building Code recognized systems)
- Full-service product support including sales and technical aspects of your project
- Labor and Material Limited Warranties exceeding other manufacturers ranging up to 20 years including Single-source envelope warranties with approved Sealant manufacturers.
- DuroTone High Performance Tint Pigments for Improved Color Retention (5-year fade warranty)
- Manufacturing strategically located in Stonecrest GA, Brookshire TX and Payson UT
- Nationwide distributor network that serves most major markets



Master Wall Inc. continuously tests our products and systems to meet the most current building codes.

FIRE TESTING			
Test	Test Method	Criteria	Results
Fire Resistance	ASTM E119	No effect on the fire resistance of a rated wall assembly	See Technical Bulletin MW#168-030111 for assemblies
Ignitability	NFPA 268 (BOCA 99/1407.0)	No ignition at 12.5 kw/m ² at 20 minutes	Pass
Intermediate Multi-Story Fire Test	NFPA 285 (UBC 26-9)	<ol style="list-style-type: none"> 1. Resist flame propagation over the exterior surface 2. Resist vertical spread of flame within combustible core/component of panel from one story to the next 3. Resist vertical spread of flame over the interior surface from one story to the next 4. Resist lateral spread of flame from the compartment of fire origin to adjacent spaces 	Pass
Surface Burning Characteristics— Base Coat, Mesh and Finish	ASTM E84	All components shall have a: Flame Spread < 25 Smoke Developed < 450	Flame Spread = 0 Smoke Developed = 0
Surface Burning Characteristics— Rollershield	ASTM E84	All components shall have a: Flame Spread < 25 Smoke Developed < 450	Flame Spread = 5 Smoke Developed = 5
Heat and Smoke Release Rates for Rollershield Air/ Water Barrier	ASTM E1354, IBC Section 1403.5, Exception 2 Requirements	Peak Heat Release Rate <150 kWm ² Total Heat Release Rate <20 MJ/m ² , Effective Heat of Combustion <18 MJ/kg	RS: Peak Heat Release Rate = 32 kWm ² , Total Heat Release Rate = 3.6 MJ/m ² , Effective Heat of Combustion = 2.5 MJ/kg, VB: Peak Heat Release Rate = 336 kWm ² , Total Heat Release Rate = 8.8 MJ/m ² , Effective Heat of Combustion = 9.3 MJ/kg

MESHES AND INSULATION BOARD			
Test	Test Method	Criteria	Results
Reinforcing Mesh Alkali Resistance of Reinforcing Mesh	ASTM E2098 (formerly EIMA 105.01)	>21dN/cm (120 pli) retained tensile strength after exposure	Pass
EPS (Physical Properties)			
Density	ASTM C303, D1622	15.2-20.0 kg/m ³ (0.95-1.25 lb/ft ³)	Pass
Thermal Resistance	ASTM C177, C518	4.0 @ 4.4 °C (40 °F)	Pass
Water Absorption	ASTM C272	3.6 @ 23.9 °C (75 °F)	
Oxygen Index	ASTM D2863	2.5 % max. by volume	Pass
Compressive Strength	ASTM D1621 Proc. A	24% min. by volume	Pass
Flexural Strength	ASTM C203	69 kPa (10 psi) min.	Pass
Flame Spread	ASTM E84	172 kPa (25 psi) min.	Pass
Smoke Developed		25 max. 450 max.	Pass Pass



EIFS & COATING

Test	Test Method	Criteria	Results
Abrasion Resistance	ASTM D968	No deleterious effects after 500 liters (528 quarts)	Pass
Accelerated Weathering	ASTM G155 Cycle 1	No deleterious effects after 2000 hours	Pass
Accelerated Weathering	ASTM G23 (G152 & 153)	No deleterious effects after 2000 hours	Pass
Accelerated Weathering	ASTM G53	No deleterious effects after 2000 hours (QUV)	Pass
Freeze-Thaw	ASTM E2485 (formerly EIMA 101.01)	No deleterious effects after 60 cycles	Pass
Freeze-Thaw	ASTM C67 modified/ICBO AC24	No deleterious effects after 10 cycles	Pass
Freeze-Thaw	ASTM E2485/ICC-ES Proc. ICC ES (AC 235)***	No deleterious effects after 10 cycles	Pass
Mildew Resistance	ASTM D3273	No growth during 28 day exposure period	Pass
Water Resistance	ASTM D2247	No deleterious effects after 14 days exposure	Pass
Impact	ASTM D5420	Gardner Impact Falling Weight	Pass
Salt Spray Resistance	ASTM B 117	No deleterious effects after 300 hours exposure	Pass
Water Penetration	ASTM E331 ICC ES (AC 235)***	No water penetration beyond the inner-most plane of the wall after 15 minutes at 137 Pa (2.86 psf)	Pass at 2.86 psf (137 Pa), 6.24 psf (299 Pa), and 12.0 psf (575 Pa) consecutively
Water Vapor Transmission	ASTM E 96 Water Method	Vapor permeable perm (ng/Pa.s.m ²)	EPS 5 perm-inch (114) Base Coat* 12 (679) Finish** 12 (674)
Component-Specific Weather Protection	IBC 1403	2-hour water test of EIFS and specific components	Pass
Drainage Efficiency	ASTM E 2273 ICC ES (AC 235)***	Minimum Drainage Efficiency of 90%	Aggre-flex Drainage 97.8% Rollershield Drainage 99.2% QRW1 Drainage 97.8%
* Base Coat perm value based on Master Wall F&M ** Finish perm value based on Master Wall Perfect Texture *** AC 235 (ASTM E 2568) – Acceptance Criteria for EIFS Clad Drainage Wall Assemblies			
Tensile Bond	ASTM C297/E2134	Minimum 15 psi (104 kPa) – substrate or insulation failure	Plywood/EPSA 67 psi (464) OSB/ EPSA 22 psi (152) Brick/F&M 105 psi (728) Concrete/F&M 94 psi (651) Gypsum/F&M 30 psi (208)
Tensile Bond	ASTM D897	Bond strength before and after 2000 hours florescent UV condensation weathering.	Before 24.6 psi After 22.7 psi
Transverse Wind Load	ASTM E330	Withstand positive and negative wind loads as specified by the building code	Pass. Assemblies vary from 68-287 psf*
* Ultimate wind loads – contact Master Wall for specific assemblies.			



IMPACT RESISTANCE (ASTM E2486/EIMA 101.86)

Description	OZ/SY	IN-LB Results	Joules	EIMA Classification
Standard Mesh	4.5	50-89	6-10	Medium
Hi-Tech Mesh	6.0	50-89	6-10	Medium
Medium Mesh	10.4	50-89	10-17	Medium
Medium & Standard Mesh	10.4 & 4.5	90-150	10-17	High Impact
Strong & Standard Mesh	15.0 & 4.5	Over 150	>17	Ultra High Impact
Ultra & Standard Mesh	21.0 & 4.5	Over 150	>17	Ultra High Impact

CEMPLASTER FIBERSTUCCO

Test	Test Method	Criteria	Results
Finishes & Coatings	Varies		Reference EIFS & Coatings Data
Freeze-Thaw	ICC AC11	No deleterious effects after 10 cycles	Pass
Transverse Load	ICC AC11/ASTM E330	Withstand positive and negative wind loads as specified by the building code	Pass. Assemblies vary from 81-124 psf*
Compressive Strength	ASTM C109	Average load for cured sample	1910 psi
Fire Resistance	ASTM E119	No effect on the fire resistance of a rated wall assembly	See Technical Bulletin MW#168-030111 for assemblies
Combustibility	ASTM E136	Standard Test Method for Assessing Combustibility of Materials in a Vertical Tube Furnace at 750°C, Option A	Pass
Accelerated Weathering	ASTM G26/G155	No deleterious effects after 2000 hours	Pass

* Ultimate wind loads – contact Master Wall for specific assemblies.



ROLLERSHIELD LAB (LIQUID APPLIED AIR/WATER BARRIER)

Test	Test Method	Criteria	Results
Solids Content	Calculation		Rollershield RS – 69.52% solids by weight (55.05% by volume), Rollershield TG – 73.85% solids by weight (60.12% by volume), Rollershield VB – 68.19% solids by weight (52.97% by volume)
Tensile Bond	ASTM C297/E2134 ICC ES (AC 212)*	Minimum 15 psi (104 kPa)	Dens Glass Gold 31 (215), Exterior Gypsum 28 (194), OSB 40 (277), Plywood 79 (563), Cement Board 70 (485), Copper 185 (1282), Galvanized steel 180 (1248), PVC 168 (1165), Aluminum 184 (1275), Coated Aluminum 203 (1407), Stainless Steel 183 (1269)
Freeze-thaw	ASTM E2485/ICC-ES Proc. ICC ES (AC 212)*	No deleterious effects after 10 cycles	Pass: Plywood, Cement Board, OSB, Exterior Gypsum (ASTM C79/C1396) and Dens Glass Gold (ASTM C1377) substrates
Water Resistance	ASTM D2247 ICC ES (AC 212)*	No deleterious effects after 14 days exposure ¹	Pass: Plywood Cement Board, OSB, Exterior Gypsum (ASTM C79/C1396) and Dens Glass Gold (ASTM C1377) substrates
Water Vapor Transmission	ASTM E96 Proc. B ICC ES (AC 212)*	Vapor Permeable	30 perms (Rollershield RS) ² 12 perms (Rollershield TG) 0.07 perms desiccant (A), 1.35 perms water (B)(Rollershield VB)
Air Permeance	ASTM E2178	No ICC or ANSI/EIMA Criteria ASHRAE/IECC max. 0.004 cfm/ft ² @ 1.57 psf	0.001 cfm/ft ² @ 1.57 psf 0.001 L/s/m ² @ 75 Pa
Air Leakage	ASTM E2357	No ICC or ANSI/EIMA Criteria ASHRAE/IECC max. 0.04 cfm/ft ² @ 1.57 psf	0.0006 cfm/ft ² @ 1.57 psf, 0.003 L/s/m ² @ 75 Pa 0.04 cfm/ft ² @ 6.24 psf, 0.02 L/s/m ² @ 300 Pa
Structural Performance	ASTM E1233 Proc. A ICC ES (AC 212)*	Minimum 10 positive cycles at 1/240 deflection; No cracking in field, at joints or interface with flashing	Pass
Racking	ASTM E72 ICC ES (AC 212)*	No cracking in field, at joints or interface with flashing at net deflection of 3.2 mm (1/8 inch)	Pass
Restrained Environmental	ICC-ES Procedure ICC ES (AC 212)*	5 cycles; No cracking in field, at joints or interface with flashing	Pass
Water Penetration	ASTM E331 ICC ES (AC 212)*	No water penetration beyond the inner-most plane of the wall after 15 minutes at 137 Pa (2.86 psf)	Pass
UV Exposure	ICC ES Proc. ICC ES (AC 212)*	210 hours of exposure, rated for 6 months of exposure	Pass
Accelerated Aging	ICC ES Proc. ICC ES (AC 212)*	25 cycles of wetting and drying	Pass
Hydrostatic Pressure Test	AATCC 127 ICC ES (AC 212)*	ICC: 549 mm (21.6 in) water column for 5 hours	Pass
Surface Burning Characteristics	ASTM E84	Flame Spread < 25 Smoke Developed < 450	Pass
Intermediate Multi-Story Fire Test	NFPA 285 (UBC 26-9)	No flame spread with up to 4" insulation	Pass
Nail Sealability	ASTM D1970	Standard Specification for Self-Adhering Polymer Modified Bituminous Sheet Materials Used as Steep Roofing Underlayment for Ice Dam Protection	Pass (22 mils)
Heat and Smoke Release Rates	ASTM E1354, IBC Section 1403.5, Exception 2 Requirements	Peak Heat Release Rate <150 kW/m ² , Total Heat Release Rate <20 MJ/m ² , Effective Heat of Combustion <18 MJ/kg	RS: Peak Heat Release Rate = 32 kW/m ² , Total Heat Release Rate = 3.6 MJ/m ² , Effective Heat of Combustion = 2.5 MJ/kg, VB: Peak Heat Release Rate = 336 kW/m ² , Total Heat Release Rate = 8.8 MJ/m ² , Effective Heat of Combustion = 9.3 MJ/kg

* (AC212 – Acceptance Criteria for Water-Resistive Coatings Used as Water-Resistive Barriers over Exterior Sheathing, also referred to as ASTM E 2570

1. No cracking, checking, rusting, crazing, erosion, blistering, peeling, or delamination when viewed under 5x magnification

2. Defined as a Class III vapor retarder per the 2015 IBC and IRC





Rollershield LAB – Liquid-applied Air/Water Barrier Section 07 27 00



Master Wall Inc.®
PO Box 397
Fortson, GA 31808
706-569-0092
800-755-0825
www.masterwall.com

Master Wall Guide Specification RSLAB Rollershield LAB

PART I – GENERAL

1.01 SUMMARY

A. This document is to be used in preparing specifications for projects utilizing the Master Wall Inc.® Rollershield Liquid-applied Air/Water Barrier (LAB) a 100% acrylic based liquid or fluid applied air and water barrier designed with low VOC and approved where a water barrier or flashing is required. Related Master Wall Inc.® documents:

1. Master Wall Inc.® Rollershield System Data Sheet
2. Master Wall Inc.® Rollershield System Application Instructions
3. Master Wall Inc.® Rollershield System Installation Details
4. Master Wall product data sheets

B. Related Sections

1. Unit Masonry – Section 04200
2. Concrete – Sections 03300 and 03400
3. Light Gauge Cold Formed Steel Framing – Section 05400
4. Wood Framing – Section 06100
5. Sealant – Section 07900
6. Flashing – Section 07600

1.02 SUBMITTALS

- A. Manufacturer's specifications, details, installation instructions and product data
- B. Manufacturer's code compliance report
- C. Manufacturer's standard warranty
- D. Applicator's industry training credentials
- E. Samples for approval as directed by architect or owner
- F. Prepare and submit project-specific details (when required by contract documents)



Rollershield LAB – Liquid-applied Air/Water Barrier Section 07 27 00

1.03 REFERENCES

A. ASTM Standards:

- ASTM C297 Tensile Bond
- ASTM C1177 Standard Specification for Glass Mat Gypsum Substrate for Use as Sheathing
- ASTM C1396 (formerly C 79) Standard Specification for Gypsum Board
- ASTM D1784 Specification for Rigid Poly (Vinyl Chloride) (PVC) and Chlorinated Poly (Vinyl Chloride) (CPVC) Compounds
- ASTM E84 Standard Test Method for Surface Burning Characteristics of Building Materials
- ASTM E72 Racking Resistance
- ASTM E96 Test Methods for Water Vapor Transmission of Materials
- ASTM E330 Test Method for Structural Performance of Exterior Windows, Doors and Curtain Walls by Uniform Static Air Pressure Difference
- ASTM E331 Test Method for Water Penetration of Exterior Windows, Skylights, Doors and Curtain Walls by Uniform Static Air Pressure Difference.
- ASTM E1233 Structural Performance
- ASTM E2134 Test Method for Evaluating the Tensile-Adhesion Performance of an Exterior Insulation and Finish System (EIFS)
- ASTM E2178 Test Method for Air Permeance of Building Materials
- ASTM E2357 Standard Test Method for Determining Air Leakage of Air Barrier Assemblies
- ASTM E2485 Freeze/Thaw Resistance
- ASTM E2568 Standard Specification for Class PB Exterior Insulation and Finish Systems
- ASTM E2570 Test Method for Water-Resistive (WRB) Coatings used Under Exterior Insulation and Finish Systems (EIFS) with Drainage

B. Building Code Standards

- AC212 Restrained Environmental Cycling, UV Exposure and Aging
- AC235 Acceptance Criteria for EIFS Clad Wall Assemblies (November, 2009)

C. National Fire Protection Association (NFPA) Standards

- NFPA 268 Standard Test Method for Determining Ignitibility of Exterior Wall Assemblies Using a Radiant Heat Energy Source
- NFPA 285 Standard Method of Test for the Evaluation of Flammability Characteristics of Exterior Non-Load Bearing Wall Assemblies containing Combustible Components Using the Intermediate-Scale, Multistory Test Apparatus

D. Other Referenced Documents

- American Association of Textile Chemists and Colorists AATCC-127 Water Resistance: Hydrostatic Pressure Test
- APA Engineered Wood Association E30, Engineered Wood Construction Guide
- UES Evaluation Report 384, Rollershield Water Barrier



Rollershield LAB – Liquid-applied Air/Water Barrier

Section 07 27 00

1.04 SYSTEM DESCRIPTION

- A. General: The Master Wall Inc.® Rollershield LAB is a fluid applied air and water barrier application. The product shall be applied over an approved substrate in accordance with the Rollershield LAB application Details.
- B. Methods of Installation
1. Field Applied: The Rollershield LAB System is applied to the substrate system in place.
 2. Panelized: The Rollershield LAB System is shop-applied to the prefabricated wall panels.
- C. Design Requirements
1. Acceptable substrates for the Rollershield LAB System shall be:
 - a. Exterior sheathing having a water-resistant core with fiberglass mat facers meeting ASTM C 1177.
 - b. Exterior fiber reinforced cement or calcium silicate boards.
 - c. APA Exterior or Exposure 1 Rated Plywood, Grade C-D or better, nominal 12.7 mm (1/2 in), minimum 4-ply.
 - d. Unglazed, unpainted brick, cement plaster, concrete, or masonry.
 - e. APA Exposure 1 rated Oriented Strand Board (OSB) or plywood, nominal 12.7 mm (1/2 in).
 - f. Other substrates approved in writing from the manufacturer.
 2. Deflection of substrate systems shall not exceed 1/240 times the span.
 3. The substrate shall be flat within 6.4 mm (1/4 in) in a 3.05 m (10 ft) radius.
 4. The slope of inclined surfaces shall not be less than 6:12, and the length shall not exceed 305 mm (12 in).
 5. Expansion Joints
 - a. Design and location of expansion joints in the Rollershield LAB System is the responsibility of the project designer and shall be noted on the project drawings. As a minimum, expansion joints shall be placed at the following locations:
 - 1) Where expansion joints occur in the substrate system.
 - 2) Where building expansion joints occur.
 - 3) At floor lines in wood frame construction (Reference Technical Bulletin #140).
 - 4) At floor lines of non-wood framed buildings where significant movement is expected.
 - 5) Where the Rollershield LAB System abuts dissimilar materials.
 - 6) Where the substrate type changes
 - 7) Where prefabricated panels abut one another
 - 8) Where significant structural movement occurs such as changes in roofline, building shape or structural system.
 6. Terminations
 - a. Interior foam expanding foam sealant may be required behind penetration openings.
 - b. Sealants
 - 1) Shall be manufactured and supplied by others.
 - 2) Shall be compatible with Rollershield LAB System materials.
 7. Vapor Retarders and barriers – The use and location of vapor retarders and/or barriers within a wall assembly is the responsibility of the project designer and shall comply with local building code requirements.
 8. Flashing: Shall be provided at all roof-wall intersections, windows, doors, chimneys, decks, balconies and other areas as necessary to prevent water from entering behind the Rollershield LAB System.



Rollershield LAB – Liquid-applied Air/Water Barrier

Section 07 27 00

1.05 PERFORMANCE REQUIREMENTS

A. Rollershield LAB System shall have been tested as follows:

Air/Moisture Barrier Performance

TEST	METHOD	CRITERIA	RESULT
1. Water Penetration Resistance	AATCC 127 (Water Column) ICC ES (AC 212)*	Resist 21.6 in (55 cm) water for 5 hours before and after aging	Pass
2. Water Penetration Resistance after Cyclic Wind Loading	ASTM E1233 / ASTM E331	No water penetration beyond the inner-most plane of the wall after 15 minutes at 137 Pa (2.86 psf)	No water penetration
3. Water Resistance Testing	ASTM D2247 ICC ES (AC 212)*	Absence of deleterious effects after 14 day exposure	Pass: Plywood Cement Board, OSB, Exterior Gypsum (ASTM C79/C1396) and Dens Glass Gold (ASTM C1377) substrates
4. Water Vapor Transmission	ASTM E96 Method B (Water Method)	Measure	30 perms (Rollershield) 12 perms (Trowelshield)
5. Air Leakage (material)	ASTM E2178	≤ 0.004 cfm/ft ² at 1.57 psf (0.02 L/s•m ² at 75 Pa)	0.0002 cfm/ft ²
6. Air Leakage (assembly)	ASTM E2357	≤ 0.04 cfm/ft ² (0.2 L/s•m ²) @ 75 Pa	0.003 L/s.m ² @ 75 Pa 0.02 L/s.m ² @ 300 Pa
7. Racking	ASTM E72 ICC ES (AC 212)*	No cracking in field, at joints or interface with flashing at net deflection of 3.2 mm (1/8 inch)	Pass
8. Freeze-thaw	ASTM E2485/ICC-ES Proc. ICC ES (AC 212)*	No deleterious effects after 10 cycles	Pass: Plywood, Cement Board, OSB, Exterior Gypsum (ASTM C79/C1396) and Dens Glass Gold (ASTM C1377) substrates
9. UV Exposure	ICC ES Proc. ICC ES (AC 212)*	210 hours of exposure	Pass
10. Surface Burning	ASTM E84	Flame Spread 0 – 25 for NFPA Class A, UBC Class I	Flame Spread: 5 Smoke Density: 5
11. Tensile Adhesion	ASTM C297	>15 psi (103 kPa)	Dens Glass Gold 31 (215), Exterior Gypsum 28 (194), OSB 40 (277), Plywood 79 (563), Cement Board 70 (485), Copper 185 (1282), Galvanized steel 180 (1248), PVC 168 (1165), Aluminum 184 (1275), Coated Aluminum 203 (1407), Stainless Steel 183 (1269)

* AC212 – Acceptance Criteria for Water-Resistive Coatings Used as Water-Resistive Barriers over Exterior Sheathing, also referred to as ASTM E 2570



Rollershield LAB – Liquid-applied Air/Water Barrier Section 07 27 00

LAB Weather Resistance and Durability Performance*

TEST	METHOD	CRITERIA	RESULTS
1. Transverse Wind Load	ASTM E330	Withstand positive and negative wind loads as specified by the building code.	Pass. Assemblies vary from 68-287 psf*

* Ultimate wind loads – contact Master Wall for specific assemblies.

Air/Moisture Barrier and LAB Fire Performance

TEST	METHOD	CRITERIA	RESULT
1. Intermediate Scale Multi-Story Fire Test	NFPA 285 (formerly UBC Standard 26-9)	<ol style="list-style-type: none"> Resistance to vertical spread of flame within the core of the panel from one story to the next Resistance to flame propagation over the exterior surface Resistance to vertical spread of flame over the interior surface from one story to the next Resistance to significant lateral spread of flame from the compartment of fire origin to adjacent spaces 	Pass
2. Surface Burning (individual components)	ASTM E84	Individual components shall each have a flame spread of 25 or less, and smoke developed of 450 or less	Flame Spread: 0 Smoke Developed: 0

1.06 QUALITY ASSURANCE

A. Qualifications

- System Manufacturer: Shall be Master Wall Inc.®. All materials shall be manufactured or sold by Master Wall Inc.® and shall be purchased from Master Wall Inc.® or its authorized distributors.
- Contractor: Shall be knowledgeable in the proper installation of the Master Wall Inc.® Rollershield LAB System. Additionally, the contractor shall possess a current Master Wall Inc.® applicator certificate issued by Master Wall Inc.®

B. Regulatory Requirements

- Continuous insulation if used shall be separated from the interior of the building by a minimum 15-minute thermal barrier.
- The use and maximum thickness of continuous insulation shall be in accordance with the applicable building codes.

C. Certification

- The Rollershield LAB System shall be recognized for the intended use by the applicable building code(s).

D. Mock-Up

- The contractor shall, before the project commences, provide the owner/architect with a mock-up for approval.
- The mock-up shall be of suitable size as required to accurately represent the products being installed, as well as each color and texture to be utilized on the project.
- The mock-up shall be prepared with the same products, tools, equipment and techniques required for the actual application. The finish used shall be from the same batch that is being used on the project.



Rollershield LAB – Liquid-applied Air/Water Barrier Section 07 27 00

4. The approved mock-up shall be available and maintained at the job site.
5. For panelized construction, the mock-up shall be available and maintained at the panel fabrication location.

1.07 DELIVERY, STORAGE AND HANDLING

- A. All Master Wall Inc.® materials shall be delivered to the job site in the original, unopened packages with labels intact.
- B. Upon arrival, materials shall be inspected for physical damage, freezing, or overheating. Questionable materials shall not be used.
- C. Deliver all materials in original unopened packages with labels intact. Verify all quantities, colors, and textures against bill of lading.
- D. Store all materials protected from direct exposure to weather conditions and at temperatures not less than 40°F (4°C) or greater than 110°F (43°C).
- E. Material Safety Data Sheets (MSDS) or Safety Data Sheets (SDS) shall be supplied for the components of the LAB and be available at the job site.

1.08 PROJECT CONDITIONS

- A. Ambient air temperatures shall be 40°F (4°C) or greater and rising at the time of installation of the Master Wall Inc.® products and shall remain at 40°F (4°C) or greater for at least 24 hours after application.
- B. Provide supplemental heat and protection as required when the temperature and conditions are not in accordance with installation requirements. Sufficient ventilation and time shall be provided to ensure that materials have sufficiently dried prior to removing supplemental heat.
- C. Adequate protection shall be provided to prevent weather conditions (humidity, temperature, and precipitation) from having an affect on the curing or drying time of Master Wall Inc.® materials.
- D. Adjacent materials and the Rollershield LAB System shall be protected during installation and while curing from weather and shall be protected from site damage.
- E. Coordinate installation of the Rollershield LAB System with related work specified in other sections to ensure that the wall assembly is protected to prevent water from getting behind the system. The cap flashing shall be installed as soon as possible after the finish coat has been applied. When this is not possible, temporary protection shall be provided immediately in this area.
- F. All sealant work shall be installed in a timely manner. Protect open joints from water intrusion during construction with backer rod, or temporary covering, until permanently sealed.
- G. Sufficient manpower and equipment shall be employed to ensure a continuous operation, free of cold joints, scaffolding lines, and texture variations, etc.
- H. Existing Conditions - The contractor shall have access to electric power, clean water, and a clean work area at the location where the Master Wall Inc.® materials are to be applied.
- I. Exposure Limitations – Rollershield LAB is limited to a maximum of 30 days exposure when Rollershield Drainage EIFS is to be adhered to the product. The surface must be clean and dry prior to application of EIFS. Under all other cladding products the exposure limitation is a maximum of six months.

1.09 SEQUENCING AND SCHEDULING

- A. Installation of the Rollershield System shall be coordinated with other construction trades.
- B. Sufficient manpower and equipment shall be employed to ensure a continuous operation.

1.10 LIMITED MATERIALS WARRANTY

- A. Provide a manufacturer's warranty against defective material upon request.

1.11 MAINTENANCE

- A. Maintenance and repair shall follow the procedures noted in Master Wall Inc.® Technical Bulletins #112 and #129.



Rollershield LAB – Liquid-applied Air/Water Barrier

Section 07 27 00

PART II – PRODUCTS

2.01 MANUFACTURER

- A. All components of the Rollershield LAB System shall be supplied or obtained from Master Wall Inc.® or its authorized distributors. Substitutions or additions of materials other than specified will void the warranty.

2.02 MATERIALS

- A. Liquid-applied Air/Water Barriers (LAB)
1. Rollershield-RS: A flexible polymer-based roll or spray applied air barrier and waterproof membrane.
 2. Rollershield-TG: A trowel grade version of Rollershield-RS.
 3. Rollershield-VB: A Class I Vapor Retarder with a vapor permeability of 0.07 perms.
- B. Sheathing Joint Treatment/Transition Treatment
1. Rollershield Flashing Tape, 4" (104 mm) width.
- C. SuperiorFlash: Moisture curing gun grade alternate treatment for flashing windows, or joints and seams of the Rollershield LAB application.
- D. Exterior Sealants (Rollershield to Penetrating Item): Single part polyurethane conforming to Federal Specification TT-S-00230C, Type II, Class A; ASTM C 920, Type S, Grade NS, Class 25, Use NT, M, A, G and I.
1. BASF Sonolastic® NP1™
 2. Sikaflex® One Part Polyurethane
 3. Tremco Vulkem Polyurethane Sealant
- E. Interior Sealants: A multi-purpose, professional, low-expansion construction adhesive and gap and crack filler. One component polyurethane foam that cures by absorbing water vapor from the air with no CFC/HCFC.
1. Wind-Lock Foam-2-Foam Adhesive
 2. Illbruck FM230 Window Seal Gun Grade Foam

PART III – EXECUTION

3.01 EXAMINATION

- A. Prior to installation of the Rollershield LAB System, the contractor shall verify that the substrate:
1. Is of a type listed.
 2. Is flat within 6.4 mm (1/4 in) in a 3 m (10 ft) radius.
 3. Is sound, dry, connections are tight, has no surface voids, projections or other conditions that may interfere with the Rollershield System installation or performance.
- B. Prior to the installation of the Rollershield LAB System, the architect or general contractor shall insure that all needed flashings and other waterproofing details have been completed, if such completion is required prior to the Rollershield application. Additionally, the Contractor shall ensure that:
1. Metal roof flashing has been installed in accordance with Asphalt Roofing Manufacturers Association (ARMA) Standards.
 2. Openings are flashed in accordance with the Rollershield LAB System Installation Details or as otherwise necessary to prevent water penetration.
 3. Chimneys, Balconies, and Decks have been properly flashed.
 4. Windows, Doors, etc. are installed and flashed per manufacturer's requirements and the Rollershield LAB System Installation Details.
- C. Prior to the installation of the Rollershield LAB System, the contractor shall notify the general contractor, and/or architect, and/or owner of all discrepancies.



Rollershield LAB – Liquid-applied Air/Water Barrier

Section 07 27 00

3.02 PREPARATION

- A. Rollershield LAB materials shall be protected by permanent or temporary means from inclement weather and other sources of damage prior to, during, and following application until completely dry.
- B. Protect adjoining work and property during Rollershield LAB installation.
- C. The substrate shall be prepared as to be free of foreign materials, such as, oil, dust, dirt, form release agents, efflorescence, paint, wax, water repellents, moisture, frost and any other condition that inhibit adhesion.

3.03 GENERAL GUIDELINES

- A. The system shall be installed in accordance with the current Master Wall Inc.® Rollershield LAB System Application Instructions.

3.04 FIELD QUALITY CONTROL

- A. The contractor shall be responsible for the proper application of the Rollershield LAB materials.
- B. Master Wall Inc.® assumes no responsibility for on-site inspections or application of its products.
- C. If required, the contractor shall certify in writing the quality of work performed relative to the substrate system, details, installation procedures, workmanship and as to the specific products used.

3.05 ROLLERSHIELD LAB APPLICATION

- A. Mixing
 - 1. Mix the products following the instructions on the product data sheets.
 - 2. Additives shall not be added to Master Wall Inc.® materials unless written approval has been received from Master Wall Inc.®
- B. Preparation
 - 1. Protect contiguous work from damage during application of the Rollershield LAB. Temporary covering may be required to prevent over spray or splattering of coatings on other work.
 - 2. Protect substrate from inclement weather during installation. Prevent infiltration of moisture behind the wall.
 - 3. Coatings shall not be installed when ambient air temperature is below 40°F (4°C). The temperature shall remain at or above 40°F (4°C) during mixing, application and until materials have dried.
 - 4. Flashings shall be installed as required by construction documents and Master Wall Inc.® details in a manner to prevent the intrusion of water behind the wall system. All flashing materials should direct the water to the exterior face of the finished wall system.
- C. Installation, General
 - 1. Reference architectural details for full wall system requirements.
 - 2. Comply with the manufacturers' current published instructions, (specifications, details, data sheets and technical bulletins) for the installation of the Rollershield LAB.
 - 3. Comply with local building codes.
 - 4. Verify that all flashings and other items are in place.
- D. Rollershield Liquid-applied Air/Water Barrier (LAB) Application
 - 1. The substrate must be approved by Master Wall Inc.®, clean, dry, structurally sound and free of efflorescence, oil, grease, form release agents and curing compounds or anything that would affect bond. Painted surfaces are not acceptable and must be removed. Substrates must be flat and free of fins or planar irregularities greater than 1/4" in 10'-0" (6.35 mm in 3.05m).

Concrete – Must have cured a minimum of 28 days prior to the application of Rollershield LAB. If form release agents or curing compounds exist on the surface, they must be removed with a solution of muriatic acid or similar product (with appropriate precautions). Remove any residual acid by flushing with water.

Brick/Masonry – If joints are not struck flush, multiple coats may be required. Contact Master Wall for more information.

Sheathing Applications - Sheathing gaps must be less than 1/4" (6.4 mm). Gap wood-based sheathing per manufacturer's recommendations, typically 1/8" (3.2 mm) minimum.



Rollershield LAB – Liquid-applied Air/Water Barrier Section 07 27 00

2. Stir the Rollershield LAB to a homogeneous consistency.
 3. Rollershield LAB is applied by first treating the joints and fastener locations, then coating the entire surface using brush, roller, trowel or airless spray equipment techniques.
 4. Apply a thin layer of Rollershield at all joints, corners, openings or transitions. While the Rollershield is still wet, center Rollershield Flashing Tape and immediately embed it into the wet Rollershield. Recoat as necessary to ensure full embedment. Spot fasteners using a paint brush or trowel and allow to dry. Rollershield LAB may be flashed into window, door and other openings using the same techniques. Reference details for flashing options.
 5. Roll or spray apply Rollershield over the prepared sheathing to a nominal uniform thickness of 15 mils wet, 10 mils dry with no pinholes or voids. When using a foam roller, a maximum $\frac{3}{4}$ " (19 mm) nap is recommended. Apply Rollershield LAB in an even, continuous coat, maintaining a wet edge of approximately 15 mils thickness, 10 mils dry. Oriented Strand Board and other porous substrates require two (2) coats of Rollershield LAB.
 6. Spray Recommendations: Rollershield is compatible with GRACO and Titan airless spray equipment with the following specifications; Minimum 1 gallon per minute output, Minimum hose width of 3/8 inch, Minimum tip size of 0.027–0.031, Minimum pressure requirement to spray of 2,000 psi at the gun with an airless sprayer rated no lower than 3,300 psi. Remove all filters in sprayer and gun before application. Hopper Gun: 3/16"-1/4" (6-6.5 mm) orifice, 23-25 psi.
 7. Rollershield must be applied as a continuous barrier of 10 mils dry thickness with no breaks or skips, although some areas will appear lighter than others due to the application process. The Rollershield application need not look like a painted surface.
 8. Repair any voids or holes with additional coats of Rollershield LAB or spot applications of Trowelshield.
 9. Allow to dry completely before proceeding with installation.
- E. Flashings or Terminations
1. Install flashing terminations as recommended. Apply a thin layer of Rollershield at the transitions. While the Rollershield is still wet, center Rollershield Flashing Tape and immediately embed it into the wet Rollershield. Recoat as necessary to ensure full embedment.
- F. Drying and Curing
1. Provide protection from rain and temperatures below 40°F (4°C) for a minimum of 24 hours after application. Longer protection may be necessary during lower temperatures and/or higher humidity conditions.
 2. Once cured, Rollershield may be exposed to the elements as long as 30-days once fully dry but should be covered as soon as practical.

3.06 JOB SITE CLEANUP

- A. Clean work area in accordance with contract documents removing all excess materials, droppings and debris. Clean adjacent surfaces.
- B. Other trades may now install their work – Sheet Metal (Section 07620), Sealants (Section 07900), Mechanical (Section 15000), Electrical (Section 16000).

3.07 PROTECTION

- A. Rollershield LAB System shall be protected from inclement weather and other sources of damage until dry and permanent protection in the form of flashings, sealants, cladding, etc. are installed.

Disclaimer

This Specification is published for general informational purposes only and is not intended to imply that these are the only materials, procedures, or methods, which are available or suitable. Materials, procedures, or methods may vary according to the particular circumstances, local building code requirements, design conditions, or statutory and regulatory requirements. While the information in this specification is believed to be accurate and reliable, it is presented without guarantee or responsibility on the part of Master Wall Inc.®



Master Wall Inc.
Building a Culture of Excellence

ROLLERSHIELD LAB

SYSTEM DETAIL

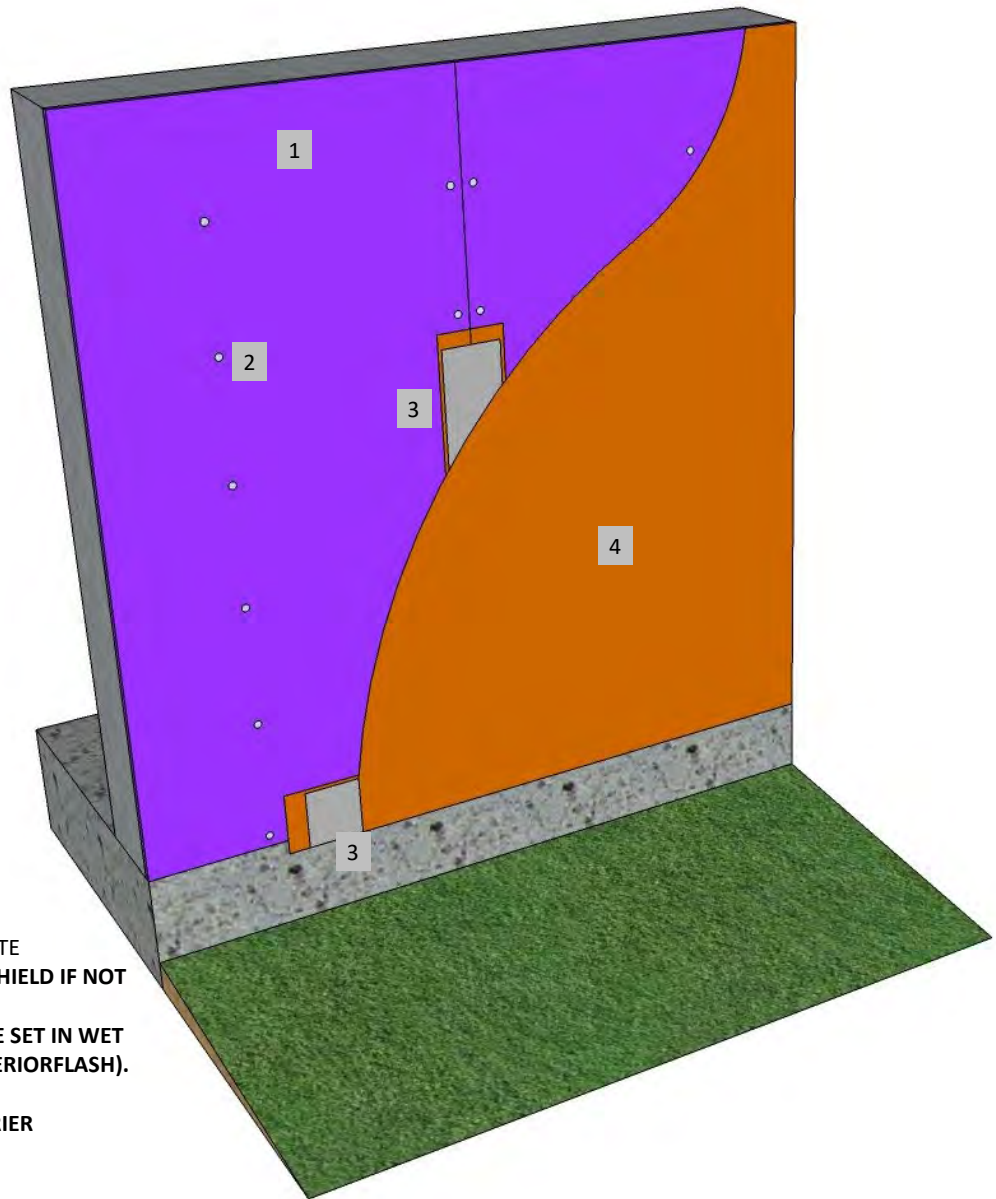

1. FRAMING & APPROVED SUBSTRATE
2. SPOT FASTENERS WITH ROLLERSHIELD IF NOT FLUSH
3. SUPERIORSHIELD FLASHING TAPE SET IN WET ROLLERSHIELD (ALTERNATE SUPERIORFLASH). LAP SPLICES 2" (51 MM) MIN.
4. ROLLERSHIELD AIR/WATER BARRIER

RSLAB-01 APPLICATION ON SHEATHING

M Master Wall Inc.
Building a Culture of Excellence

PO Box 397 · Fortson · GA · 31808 · 800-755-0825 · masterwall.com

These drawings relay the conceptual conditions of Master Wall® Systems and are not the construction drawings. Ultimately the design and detailing of an entire wall system is the responsibility of a professional. These details will guide the design professional in the use of Master Wall® Products. Master Wall disclaims design, warranty or construction intent or responsibility. Bold or Brand Name = Master Wall® Product. ©2025 Master Wall Inc.®



Master Wall Inc.®
Building a Culture of Excellence

ROLLERSHIELD LAB

SYSTEM DETAIL

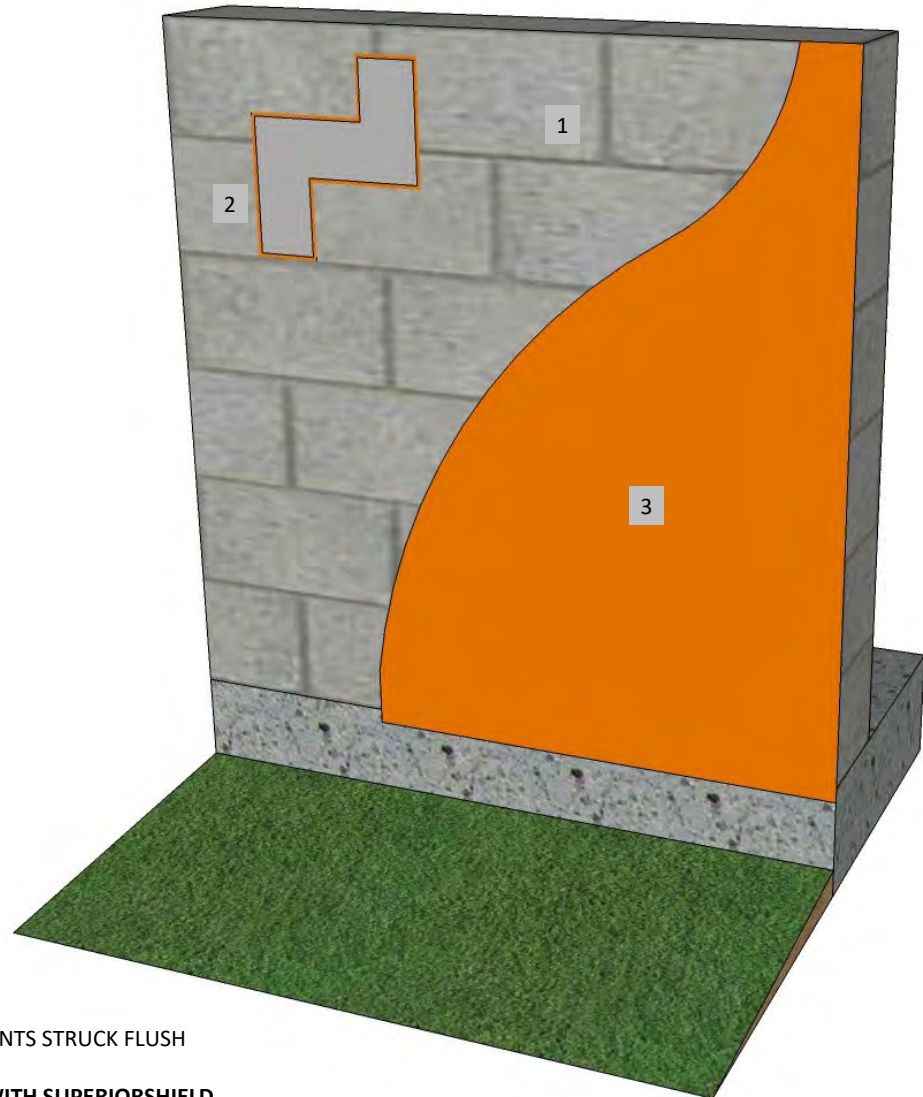

1. APPROVED SUBSTRATE, MASONRY JOINTS STRUCK FLUSH PREFERRED
2. REPAIR ANY CRACKS IN SUBSTRATE WITH SUPERIORSHIELD FLASHING TAPE SET IN WET ROLLERSHIELD (ALTERNATE SUPERIORFLASH). LAP SPLICES 2" (51 MM) MIN.
3. ROLLERSHIELD AIR/WATER BARRIER

RSLAB-02 APPLICATION ON CMU, MASONRY OR CONCRETE

M Master Wall Inc.®
Building a Culture of Excellence

PO Box 397 · Fortson · GA · 31808 · 800-755-0825 · masterwall.com

These drawings relay the conceptual conditions of Master Wall® Systems and are not the construction drawings. Ultimately the design and detailing of an entire wall system is the responsibility of a professional. These details will guide the design professional in the use of Master Wall® Products. Master Wall disclaims design, warranty or construction intent or responsibility. Bold or Brand Name = Master Wall® Product. ©2025 Master Wall Inc.®



Master Wall Inc.
Building a Culture of Excellence

ROLLERSHIELD LAB

SYSTEM DETAIL

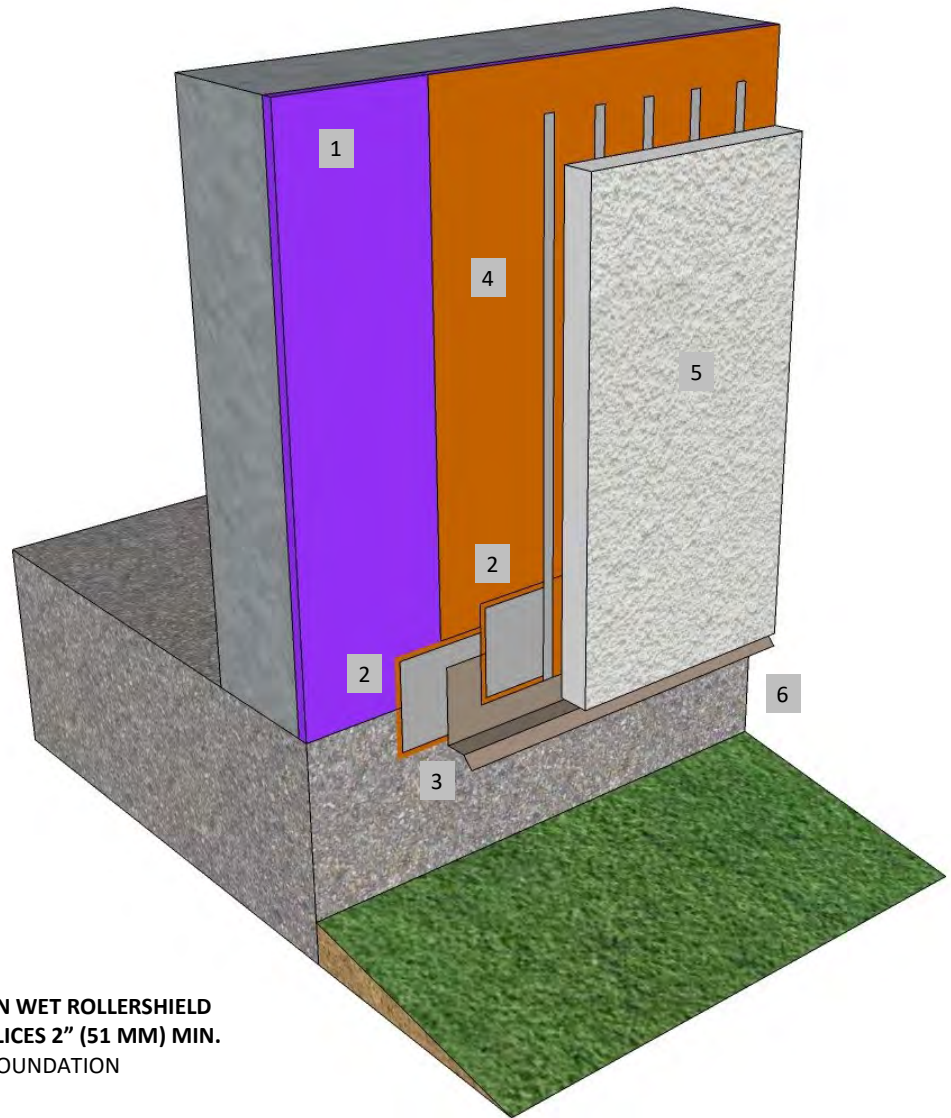

1. FRAMING & APPROVED SUBSTRATE
2. SUPERIORSHIELD FLASHING TAPE SET IN WET ROLLERSHIELD (ALTERNATE SUPERIORFLASH). LAP SPLICES 2" (51 MM) MIN.
3. FLASHING SET 1" (25 MM) MIN. OVER FOUNDATION
4. ROLLERSHIELD AIR/WATER BARRIER
5. ROLLERSHIELD DRAINAGE CIFS®
6. KEEP SYSTEM 6" (152 MM) MIN. ABOVE GRADE

RSLAB-03 CIFS® OR EIFS TERMINATION

M Master Wall Inc.
Building a Culture of Excellence

PO Box 397 · Fortson · GA · 31808 · 800-755-0825 · masterwall.com

These drawings relay the conceptual conditions of Master Wall® Systems and are not the construction drawings. Ultimately the design and detailing of an entire wall system is the responsibility of a professional. These details will guide the design professional in the use of Master Wall® Products. Master Wall disclaims design, warranty or construction intent or responsibility. Bold or Brand Name = Master Wall® Product. ©2025 Master Wall Inc.®



Master Wall Inc.
Building a Culture of Excellence

ROLLERSHIELD LAB

SYSTEM DETAIL

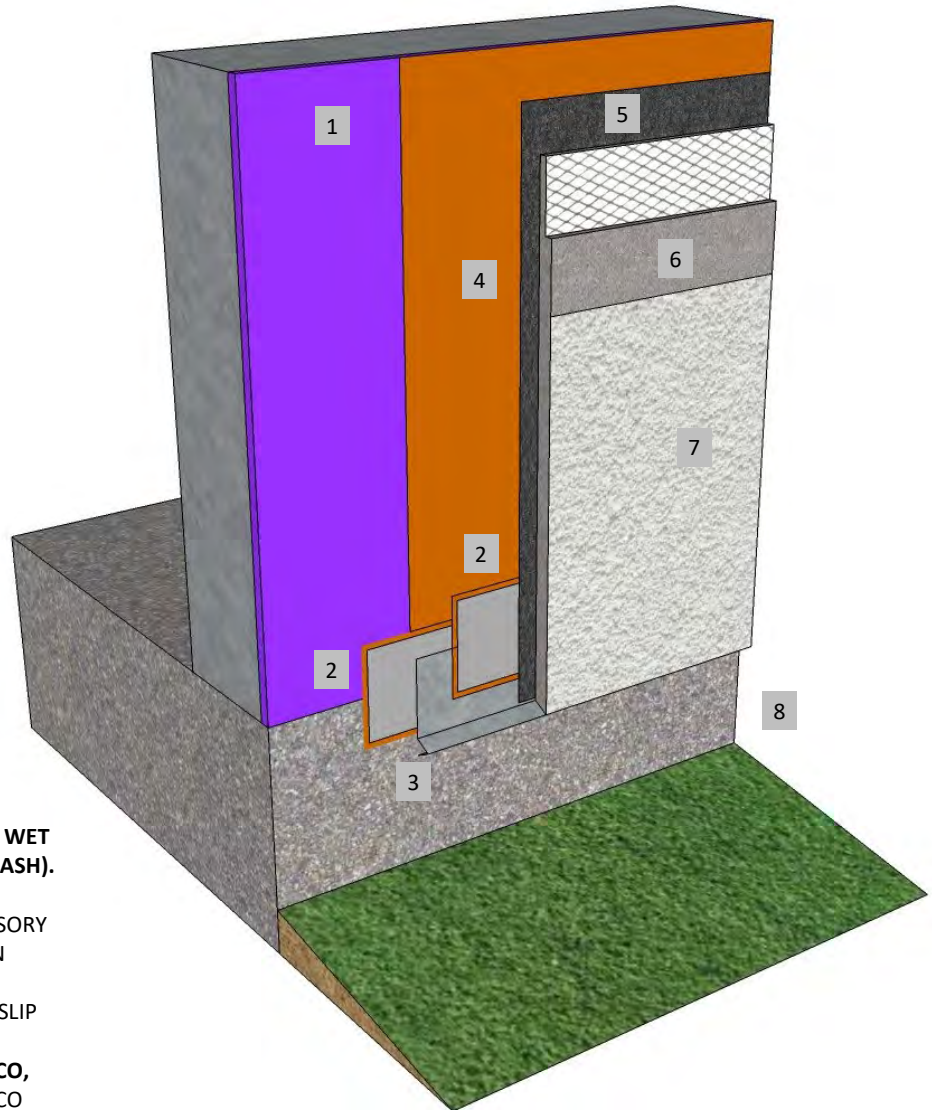

1. FRAMING & APPROVED SUBSTRATE
2. SUPERIORSHIELD FLASHING TAPE SET IN WET ROLLERSHIELD (ALTERNATE SUPERIORFLASH), LAP SPLICES 2" (51 MM) MIN.
3. STUCCO WEEP SCREED OR OTHER ACCESSORY SET 1" (25 MM) MIN. OVER FOUNDATION
4. ROLLERSHIELD AIR/WATER BARRIER
5. SECONDARY WATER RESISTIVE BARRIER, SLIP SHEET OR DRAINAGE MAT
6. MASTER WALL CEMPLASTER FIBERSTUCCO, ONE COAT STUCCO OR ASTM C926 STUCCO
7. MASTER WALL SUPERIOR FINISH
8. KEEP SYSTEM 6" (152 MM) MIN. ABOVE GRADE

RSLAB-04 STUCCO TERMINATION AT FOUNDATION

M Master Wall Inc.
Building a Culture of Excellence

PO Box 397 · Fortson · GA · 31808 · 800-755-0825 · masterwall.com

These drawings relay the conceptual conditions of Master Wall® Systems and are not the construction drawings. Ultimately the design and detailing of an entire wall system is the responsibility of a professional. These details will guide the design professional in the use of Master Wall® Products. Master Wall disclaims design, warranty or construction intent or responsibility. Bold or Brand Name = Master Wall® Product. ©2025 Master Wall Inc.®



Master Wall Inc.
Building a Culture of Excellence

ROLLERSHIELD LAB

SYSTEM DETAIL

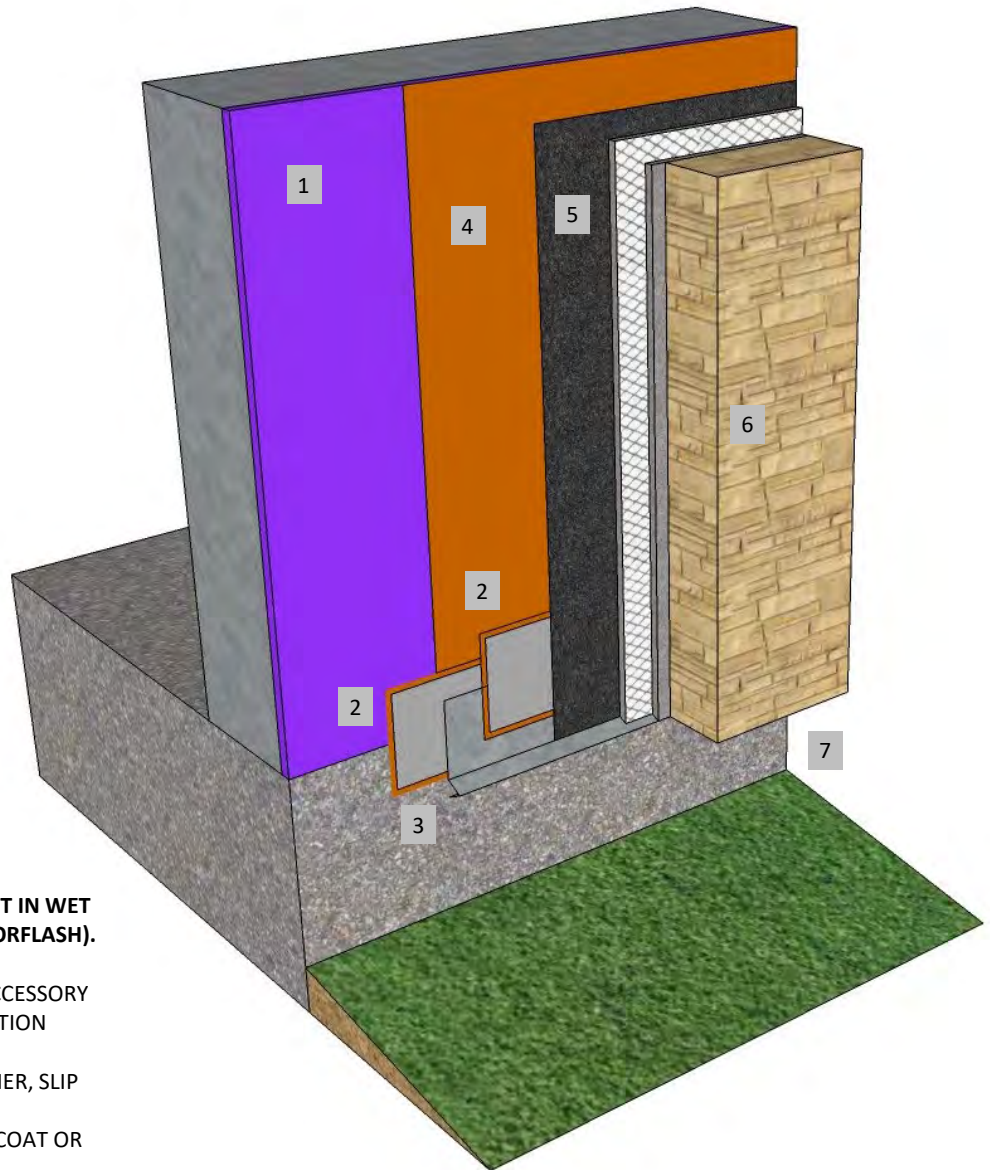

1. FRAMING & APPROVED SUBSTRATE
2. **SUPERIORSHIELD FLASHING TAPE SET IN WET ROLLERSHIELD (ALTERNATE SUPERIORFLASH). LAP SPLICES 2" (51 MM) MIN.**
3. STUCCO WEEP SCREED OR OTHER ACCESSORY SET 1" (25 MM) MIN. OVER FOUNDATION
4. **ROLLERSHIELD AIR/WATER BARRIER**
5. SECONDARY WATER RESISTIVE BARRIER, SLIP SHEET OR DRAINAGE MAT
6. THIN BRICK OR STONE ON SCRATCH COAT OR OTHER APPLICATION
7. KEEP SYSTEM 6" (152 MM) MIN. ABOVE GRADE

RSLAB-05 STONE TERMINATION AT FOUNDATION

M Master Wall Inc.
Building a Culture of Excellence

PO Box 397 · Fortson · GA · 31808 · 800-755-0825 · masterwall.com

These drawings relay the conceptual conditions of Master Wall® Systems and are not the construction drawings. Ultimately the design and detailing of an entire wall system is the responsibility of a professional. These details will guide the design professional in the use of Master Wall® Products. Master Wall disclaims design, warranty or construction intent or responsibility. Bold or Brand Name = Master Wall® Product. ©2025 Master Wall Inc.®



Master Wall Inc.®
Building a Culture of Excellence

ROLLERSHIELD LAB

SYSTEM DETAIL

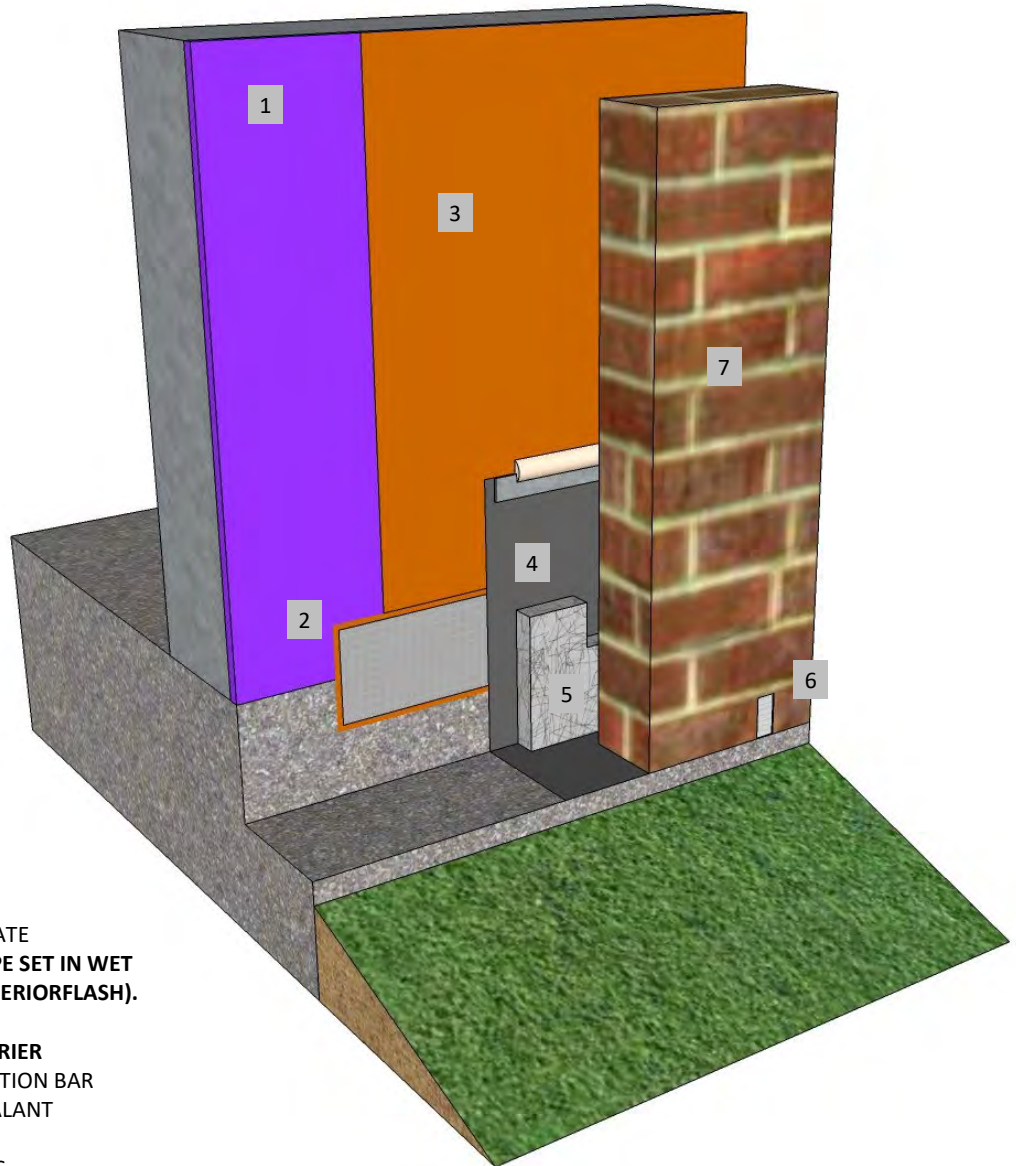

1. FRAMING & APPROVED SUBSTRATE
2. SUPERIORSHIELD FLASHING TAPE SET IN WET ROLLERSHIELD (ALTERNATE SUPERIORFLASH). LAP SPLICES 2" (51 MM) MIN.
3. ROLLERSHIELD AIR/WATER BARRIER
4. BRICK FLASHING WITH TERMINATION BAR AND COMPATIBLE EXTERIOR SEALANT
5. MORTAR PROTECTION
6. WEEP HOLES IN VERTICAL JOINTS
7. BRICK

RSLAB-06 BRICK TERMINATION AT FOUNDATION

M Master Wall Inc.®
Building a Culture of Excellence

PO Box 397 · Fortson · GA · 31808 · 800-755-0825 · masterwall.com

These drawings relay the conceptual conditions of Master Wall® Systems and are not the construction drawings. Ultimately the design and detailing of an entire wall system is the responsibility of a professional. These details will guide the design professional in the use of Master Wall® Products. Master Wall disclaims design, warranty or construction intent or responsibility. Bold or Brand Name = Master Wall® Product. ©2025 Master Wall Inc.®



Master Wall Inc.®
Building a Culture of Excellence

ROLLERSHIELD LAB

SYSTEM DETAIL

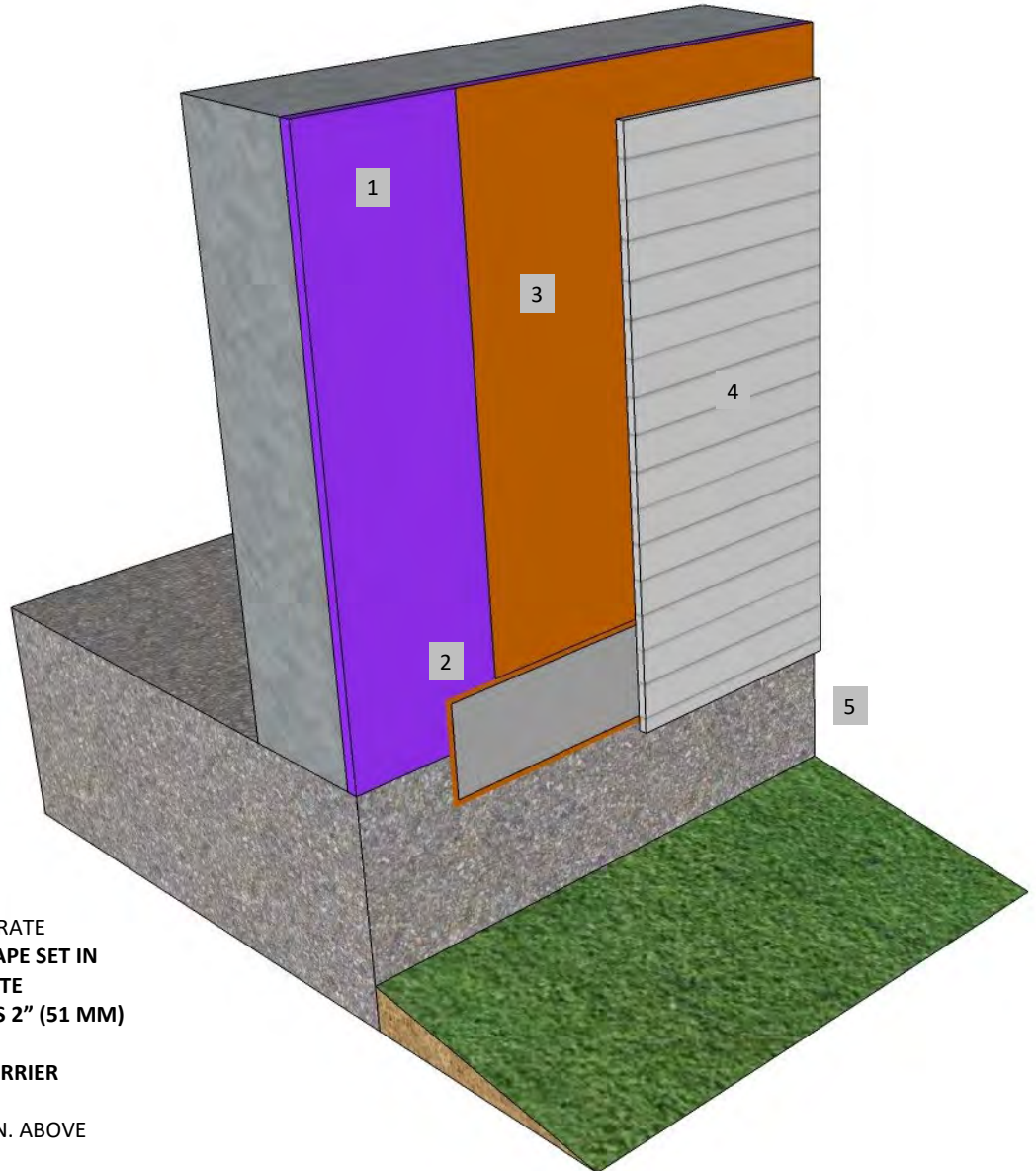

1. FRAMING & APPROVED SUBSTRATE
2. SUPERIORSHIELD FLASHING TAPE SET IN WET ROLLERSHIELD (ALTERNATE SUPERIORFLASH). LAP SPLICES 2" (51 MM) MIN.
3. ROLLERSHIELD AIR/WATER BARRIER
4. SIDING
5. KEEP SYSTEM 6" (152 MM) MIN. ABOVE GRADE

RSLAB-07 SIDING TERMINATION AT FOUNDATION

M Master Wall Inc.®
Building a Culture of Excellence

PO Box 397 · Fortson · GA · 31808 · 800-755-0825 · masterwall.com

These drawings relay the conceptual conditions of Master Wall® Systems and are not the construction drawings. Ultimately the design and detailing of an entire wall system is the responsibility of a professional. These details will guide the design professional in the use of Master Wall® Products. Master Wall disclaims design, warranty or construction intent or responsibility. Bold or Brand Name = Master Wall® Product. ©2025 Master Wall Inc.®



Master Wall Inc.®
Building a Culture of Excellence

ROLLERSHIELD LAB

SYSTEM DETAIL

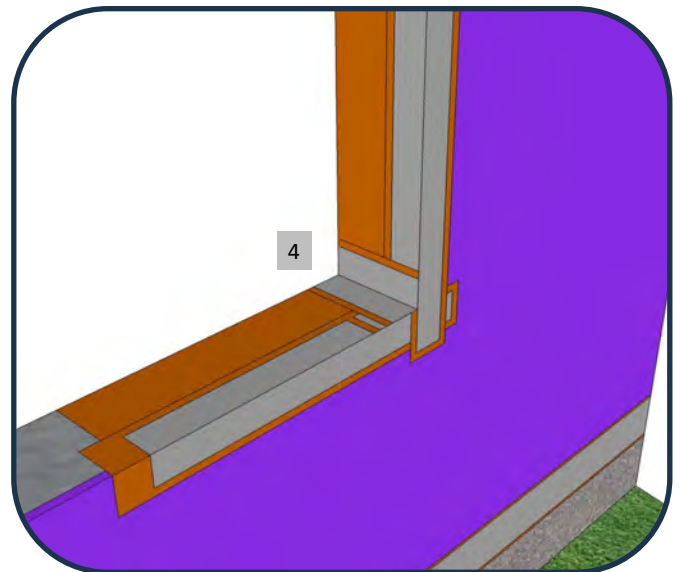
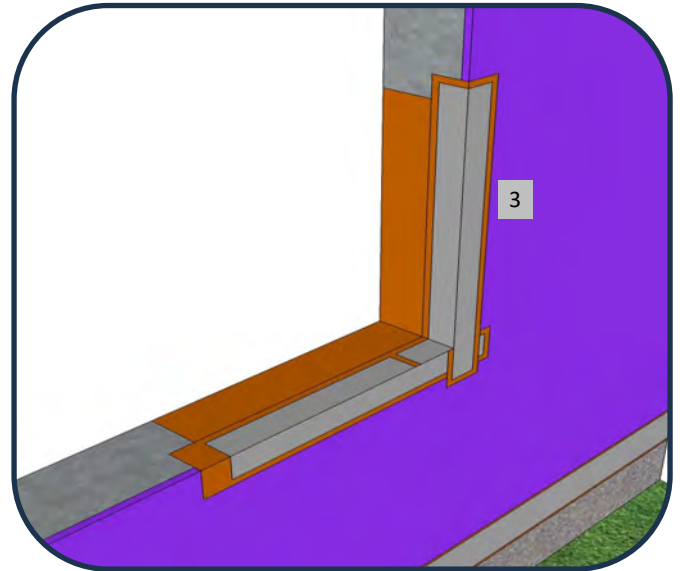
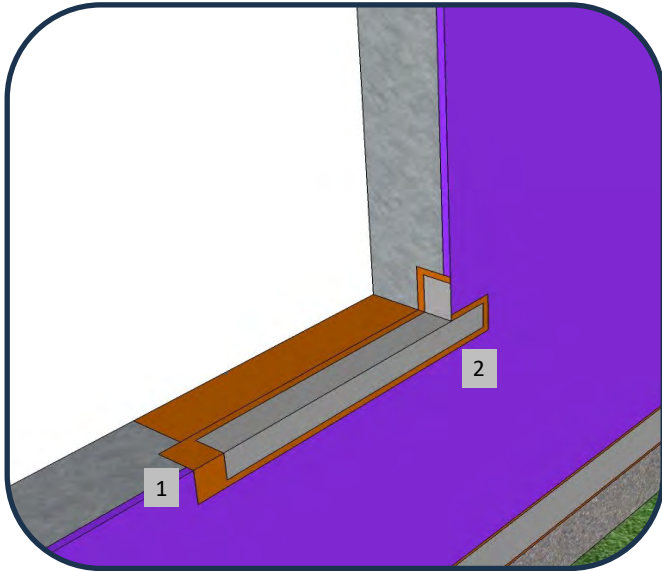

1. START AT THE BASE OF THE WINDOW. APPLY WET **ROLLERSHIELD** USING A TROWEL, BRUSH OR ROLLER TO THE SILL AND FACE OF THE WALL.
2. CENTER AND EMBED **SUPERIORSHIELD FLASHING TAPE** INTO THE WET **ROLLERSHIELD** AND EXTEND UP THE WALL 3" (75 MM) UP THE JAMBS AND ONTO THE FACE OF THE WALL. SMOOTH USING TROWEL, BRUSH OR ROLLER.
3. APPLY JAMB FLASHING IN A SIMILAR MANNER EXTENDING THE FLASHING 3" MIN. ONTO THE SILL SURFACE.
4. SEAL CORNER WITH AN ADDITIONAL STRIP OF **ROLLERSHIELD FLASHING TAPE** CENTERED IN THE CORNER
5. APPLY HEAD FLASHING IN A SIMILAR MANNER (NOT SHOWN).

RSLAB-08 BASIC FLASHING – METHOD A

M Master Wall Inc.®
Building a Culture of Excellence

PO Box 397 · Fortson · GA · 31808 · 800-755-0825 · masterwall.com

These drawings relay the conceptual conditions of Master Wall® Systems and are not the construction drawings. Ultimately the design and detailing of an entire wall system is the responsibility of a professional. These details will guide the design professional in the use of Master Wall® Products. Master Wall disclaims design, warranty or construction intent or responsibility. Bold or Brand Name = Master Wall® Product. ©2025 Master Wall Inc.®



Master Wall Inc.
Building a Culture of Excellence

ROLLERSHIELD LAB

SYSTEM DETAIL

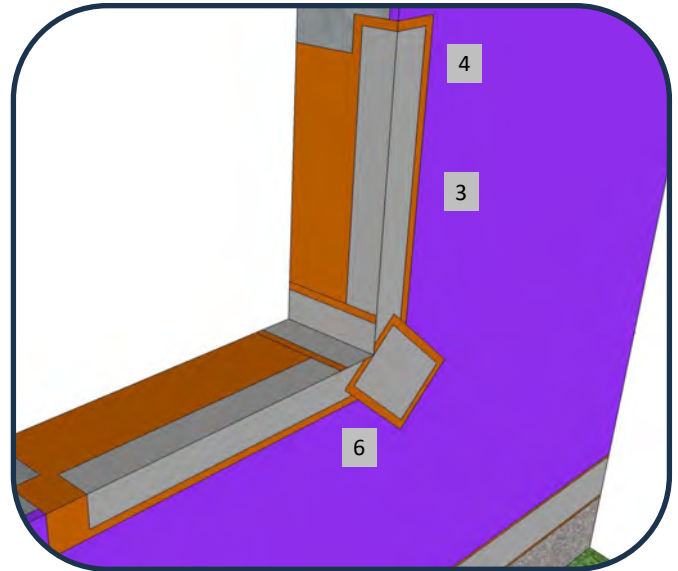
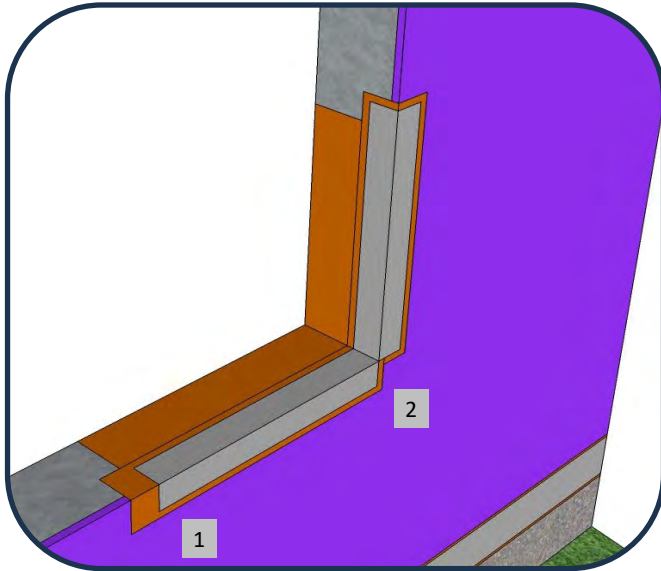

1. START AT THE BASE OF THE WINDOW. APPLY WET **ROLLERSHIELD** USING A TROWEL, BRUSH OR ROLLER TO THE SILL AND FACE OF THE WALL.
2. CENTER AND EMBED **SUPERIORSHIELD FLASHING TAPE** INTO THE WET **ROLLERSHIELD**. SMOOTH USING TROWEL, BRUSH OR ROLLER.
3. APPLY JAMB FLASHING IN A SIMILAR MANNER.
4. APPLY HEAD FLASHING IN A SIMILAR MANNER (NOT SHOWN).
5. CREATE DIAGONAL REINFORCEMENT BY CUTTING A PIECE OF **SUPERIORSHIELD FLASHING TAPE** TWICE THE DEPTH OF THE OPENING AND CAREFULLY CUT LEAVING 1-2 STRANDS
6. APPLY WET **ROLLERSHIELD** AT ALL CORNERS AND EMBED DIAGONAL REINFORCEMENT.

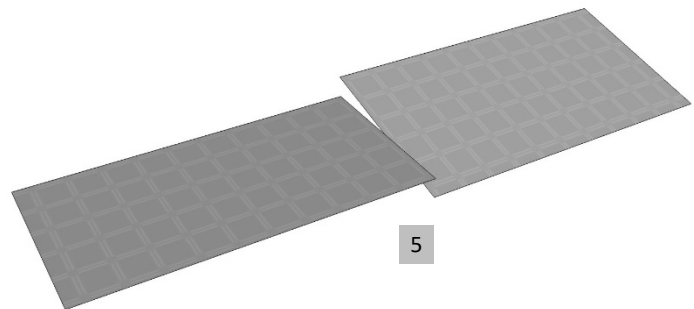

RSLAB-09 BASIC FLASHING – METHOD B

M Master Wall Inc.
Building a Culture of Excellence

PO Box 397 · Fortson · GA · 31808 · 800-755-0825 · masterwall.com

These drawings relay the conceptual conditions of Master Wall® Systems and are not the construction drawings. Ultimately the design and detailing of an entire wall system is the responsibility of a professional. These details will guide the design professional in the use of Master Wall® Products. Master Wall disclaims design, warranty or construction intent or responsibility. Bold or Brand Name = Master Wall® Product. ©2025 Master Wall Inc.®



Master Wall Inc.®
Building a Culture of Excellence

ROLLERSHIELD LAB

SYSTEM DETAIL

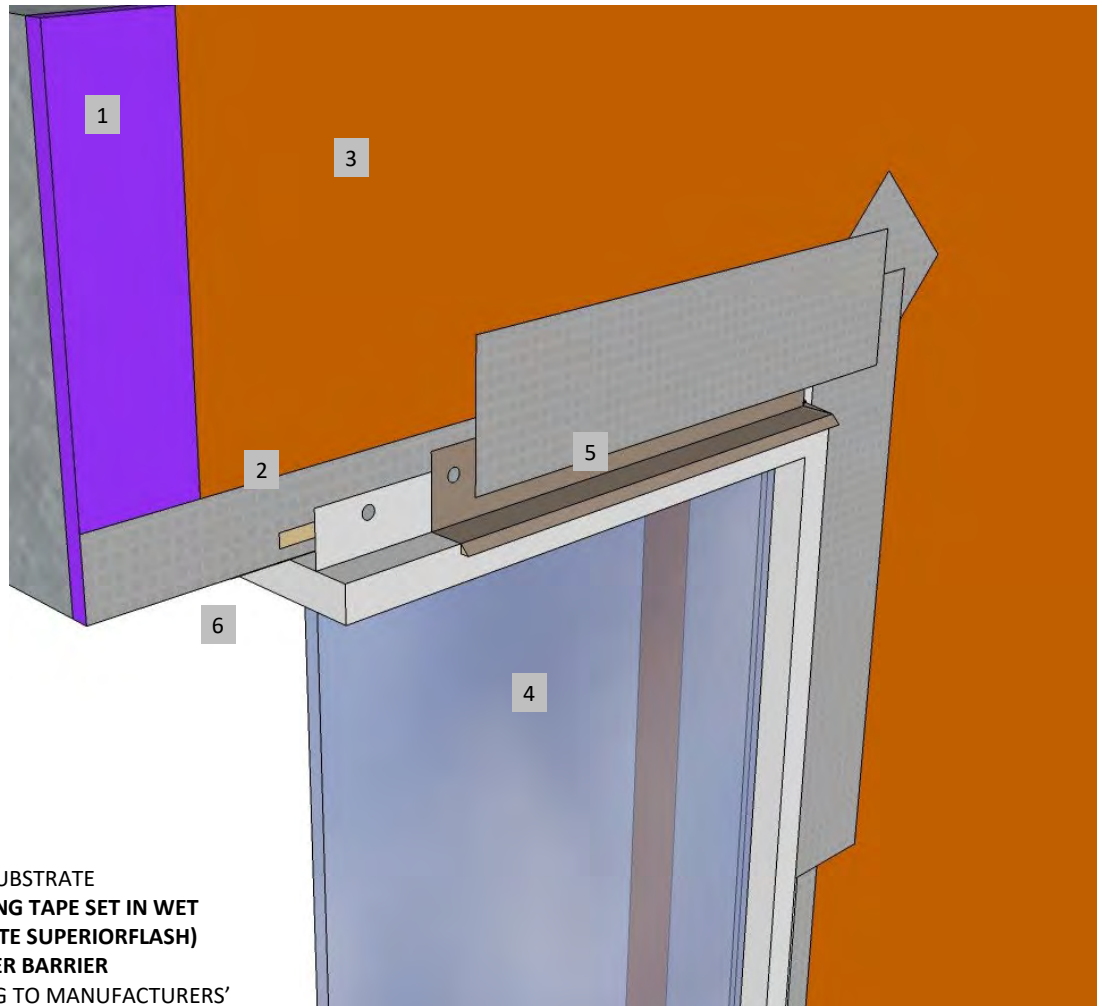

1. FRAMING & APPROVED SUBSTRATE
2. SUPERIORSHIELD FLASHING TAPE SET IN WET ROLLERSHIELD (ALTERNATE SUPERIORFLASH)
3. ROLLERSHIELD AIR/WATER BARRIER
4. WINDOW SET ACCORDING TO MANUFACTURERS' INSTRUCTIONS
5. HEAD FLASHING WITH END DAMS SHOWN, SET IN SEALANT. FLASH ONTO WINDOW FLANGE IF SELF-FLASHING WINDOW IS USED
6. INTERIOR SEALANT (NOT SHOWN)

RSLAB-10 WINDOW HEAD DETAIL

M Master Wall Inc.®
Building a Culture of Excellence

PO Box 397 · Fortson · GA · 31808 · 800-755-0825 · masterwall.com

These drawings relay the conceptual conditions of Master Wall® Systems and are not the construction drawings. Ultimately the design and detailing of an entire wall system is the responsibility of a professional. These details will guide the design professional in the use of Master Wall® Products. Master Wall disclaims design, warranty or construction intent or responsibility. Bold or Brand Name = Master Wall® Product. ©2025 Master Wall Inc.®



Master Wall Inc.®
Building a Culture of Excellence

ROLLERSHIELD LAB

SYSTEM DETAIL

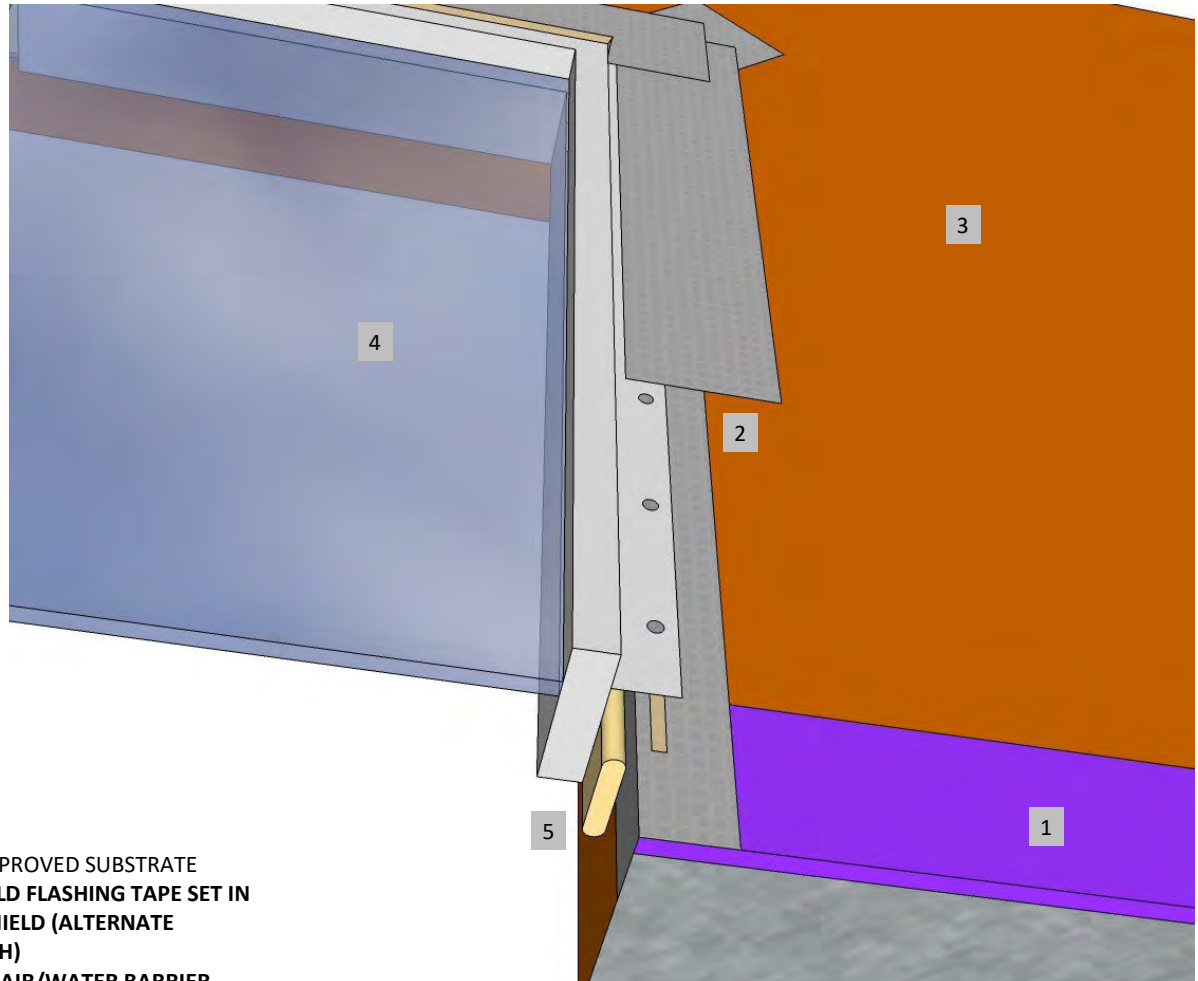

1. FRAMING & APPROVED SUBSTRATE
2. SUPERIORSHIELD FLASHING TAPE SET IN WET ROLLERSHIELD (ALTERNATE SUPERIORFLASH)
3. ROLLERSHIELD AIR/WATER BARRIER
4. WINDOW SET ACCORDING TO MANUFACTURERS' INSTRUCTIONS
5. INTERIOR SEALANT

RSLAB-11 TYPICAL WINDOW JAMB DETAIL

M Master Wall Inc.®
Building a Culture of Excellence

PO Box 397 · Fortson · GA · 31808 · 800-755-0825 · masterwall.com

These drawings relay the conceptual conditions of Master Wall® Systems and are not the construction drawings. Ultimately the design and detailing of an entire wall system is the responsibility of a professional. These details will guide the design professional in the use of Master Wall® Products. Master Wall disclaims design, warranty or construction intent or responsibility. Bold or Brand Name = Master Wall® Product. ©2025 Master Wall Inc.®



Master Wall Inc.
Building a Culture of Excellence

ROLLERSHIELD LAB

SYSTEM DETAIL

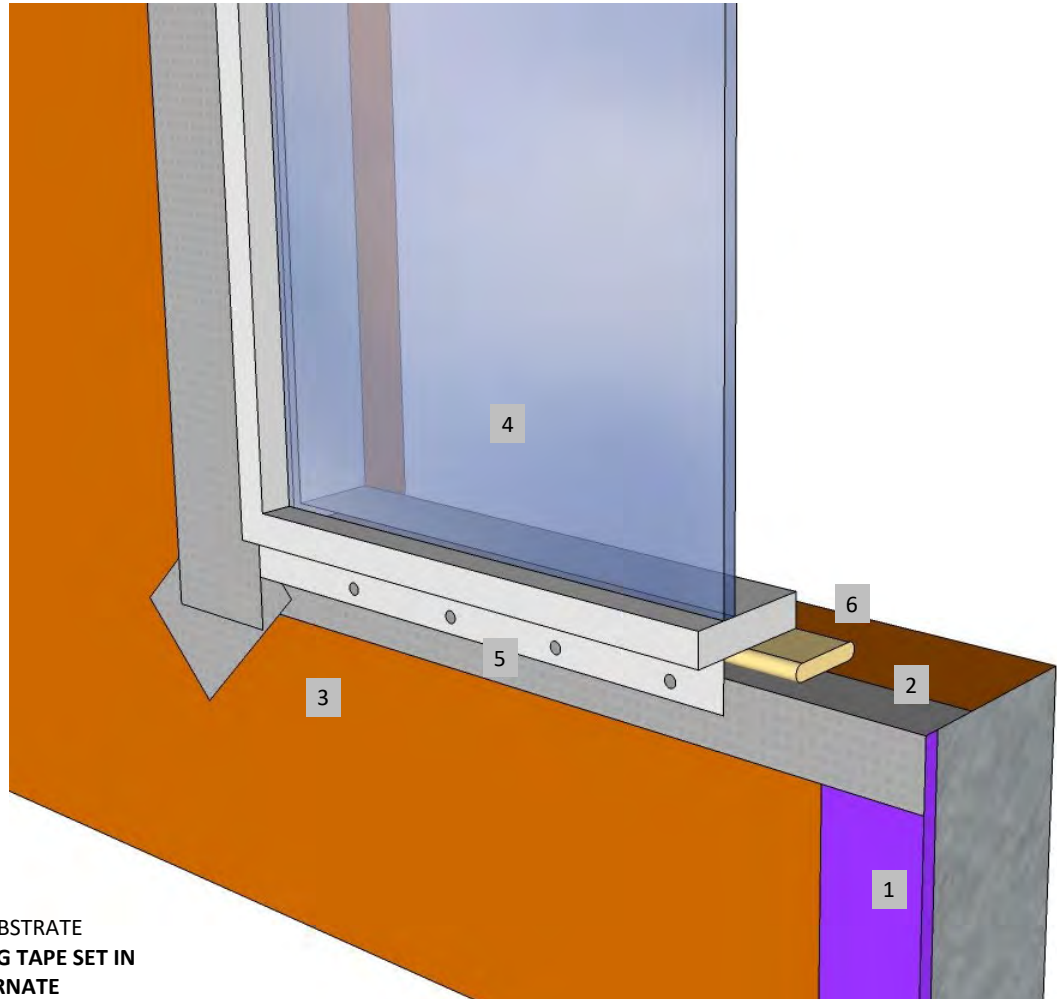

1. FRAMING & APPROVED SUBSTRATE
2. SUPERIORSHIELD FLASHING TAPE SET IN WET ROLLERSHIELD (ALTERNATE SUPERIORFLASH)
3. ROLLERSHIELD AIR/WATER BARRIER
4. WINDOW SET ACCORDING TO MANUFACTURERS' INSTRUCTIONS
5. LOWER FLANGE SHOWN OPEN FOR DRAINAGE, VERIFY WITH WINDOW MANUFACTURER
6. INTERIOR SEALANT

RSLAB-12 TYPICAL WINDOW SILL DETAIL

M Master Wall Inc.
Building a Culture of Excellence

PO Box 397 · Fortson · GA · 31808 · 800-755-0825 · masterwall.com

These drawings relay the conceptual conditions of Master Wall® Systems and are not the construction drawings. Ultimately the design and detailing of an entire wall system is the responsibility of a professional. These details will guide the design professional in the use of Master Wall® Products. Master Wall disclaims design, warranty or construction intent or responsibility. Bold or Brand Name = Master Wall® Product. ©2025 Master Wall Inc.®



Master Wall Inc.
Building a Culture of Excellence

ROLLERSHIELD LAB

SYSTEM DETAIL

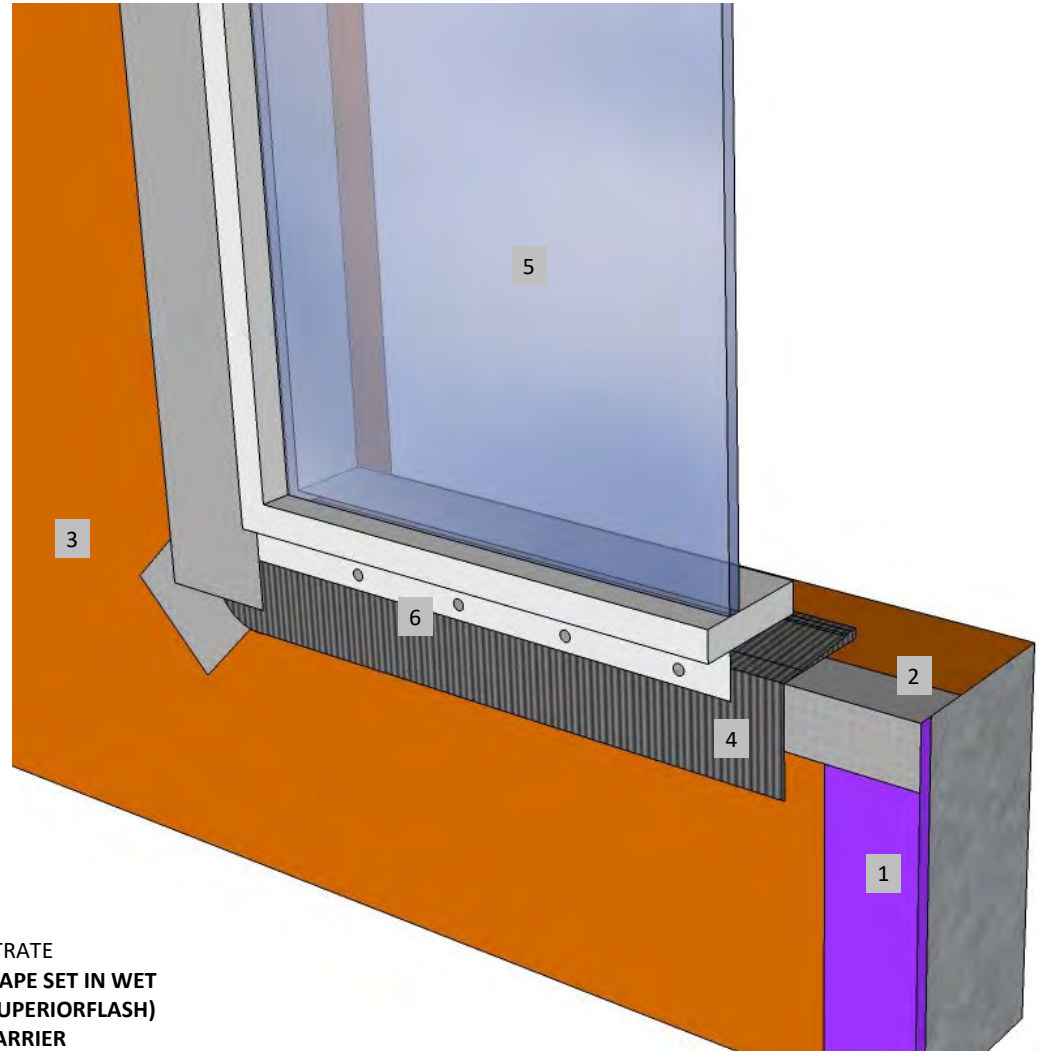

1. FRAMING & APPROVED SUBSTRATE
2. SUPERIORSHIELD FLASHING TAPE SET IN WET ROLLERSHIELD (ALTERNATE SUPERIORFLASH)
3. ROLLERSHIELD AIR/WATER BARRIER
4. SILLDRY® SILL PAN SET TO MANUFACTURER'S INSTRUCTIONS, FLASHED WITH ROLLERSHIELD AND SUPERIORSHIELD FLASHING TAPE
5. WINDOW SET ACCORDING TO MANUFACTURERS' INSTRUCTIONS
6. LOWER FLANGE SHOWN OPEN FOR DRAINAGE, VERIFY WITH WINDOW MANUFACTURER

RSLAB-13 SILLDRY® WINDOW SILL

M Master Wall Inc.
Building a Culture of Excellence

PO Box 397 · Fortson · GA · 31808 · 800-755-0825 · masterwall.com

These drawings relay the conceptual conditions of Master Wall® Systems and are not the construction drawings. Ultimately the design and detailing of an entire wall system is the responsibility of a professional. These details will guide the design professional in the use of Master Wall® Products. Master Wall disclaims design, warranty or construction intent or responsibility. Bold or Brand Name = Master Wall® Product. ©2025 Master Wall Inc.®



Master Wall Inc.®
Building a Culture of Excellence

ROLLERSHIELD LAB

SYSTEM DETAIL

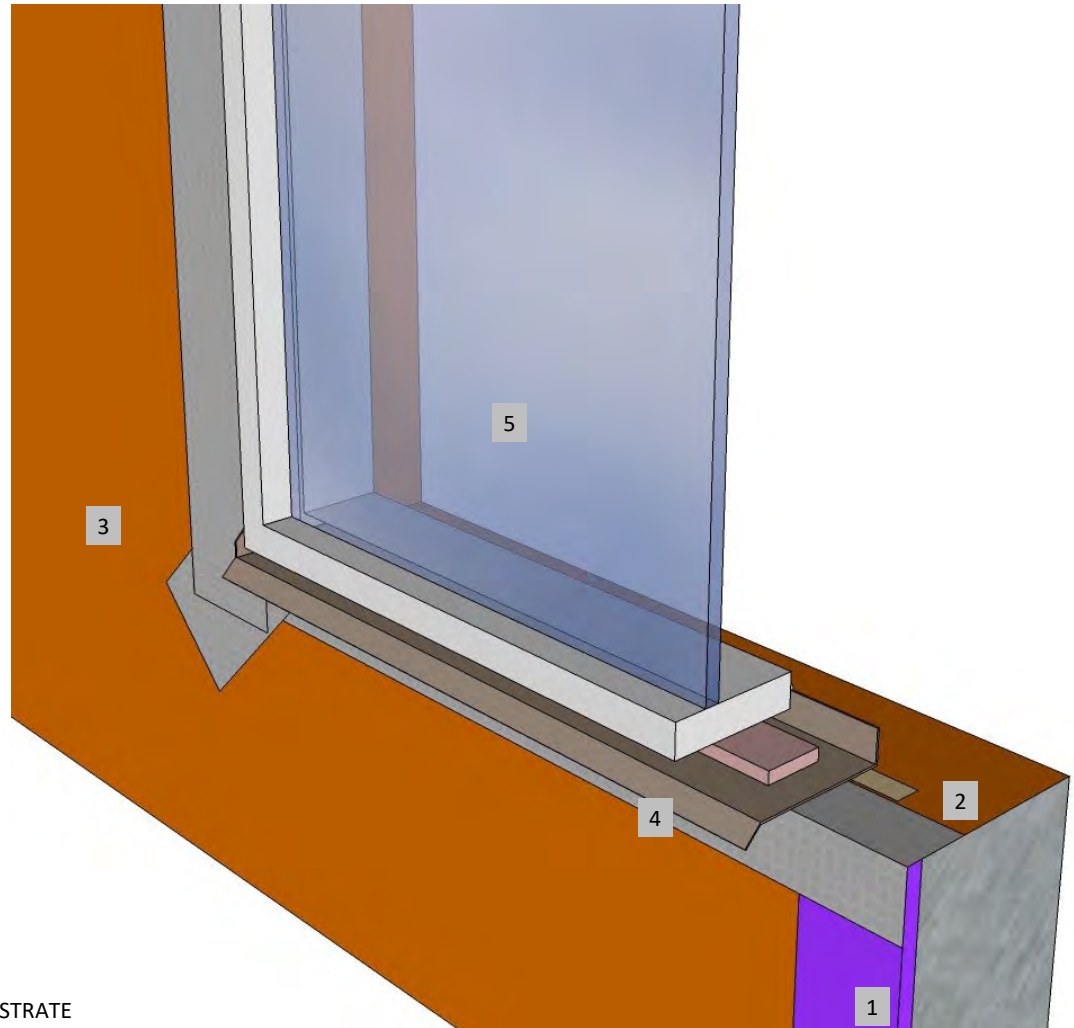

1. FRAMING & APPROVED SUBSTRATE
2. SUPERIORSHIELD FLASHING TAPE SET IN WET ROLLERSHIELD (ALTERNATE SUPERIORFLASH)
3. ROLLERSHIELD AIR/WATER BARRIER
4. SILL PAN WITH END DAMS, SET IN SEALANT
5. WINDOW SET ACCORDING TO MANUFACTURERS' INSTRUCTIONS

RSLAB-14 TYPICAL WINDOW SILL PAN

M Master Wall Inc.®
Building a Culture of Excellence

PO Box 397 · Fortson · GA · 31808 · 800-755-0825 · masterwall.com

These drawings relay the conceptual conditions of Master Wall® Systems and are not the construction drawings. Ultimately the design and detailing of an entire wall system is the responsibility of a professional. These details will guide the design professional in the use of Master Wall® Products. Master Wall disclaims design, warranty or construction intent or responsibility. Bold or Brand Name = Master Wall® Product. ©2025 Master Wall Inc.®



Master Wall Inc.®
Building a Culture of Excellence

ROLLERSHIELD LAB

SYSTEM DETAIL

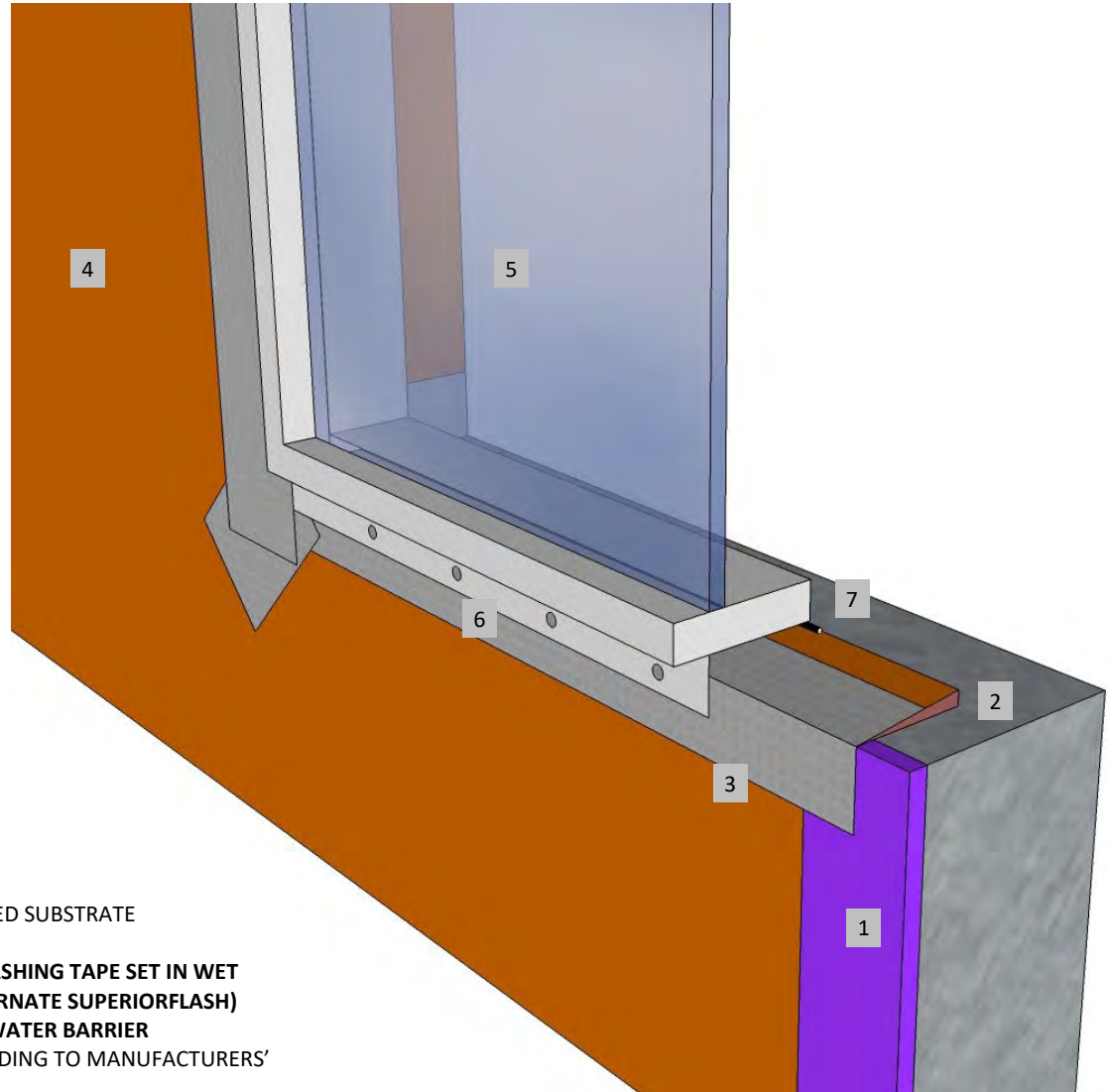

1. FRAMING & APPROVED SUBSTRATE
2. SILL WEDGE
3. SUPERIORSHIELD FLASHING TAPE SET IN WET ROLLERSHIELD (ALTERNATE SUPERIORFLASH)
4. ROLLERSHIELD AIR/WATER BARRIER
5. WINDOW SET ACCORDING TO MANUFACTURERS' INSTRUCTIONS
6. LOWER FLANGE SHOWN OPEN FOR DRAINAGE, VERIFY WITH WINDOW MANUFACTURER
7. INTERIOR SEALANT

RSLAB-15 TYPICAL WINDOW SILL WEDGE

M Master Wall Inc.®
Building a Culture of Excellence

PO Box 397 · Fortson · GA · 31808 · 800-755-0825 · masterwall.com

These drawings relay the conceptual conditions of Master Wall® Systems and are not the construction drawings. Ultimately the design and detailing of an entire wall system is the responsibility of a professional. These details will guide the design professional in the use of Master Wall® Products. Master Wall disclaims design, warranty or construction intent or responsibility. Bold or Brand Name = Master Wall® Product. ©2025 Master Wall Inc.®



Master Wall Inc.®
Building a Culture of Excellence

ROLLERSHIELD LAB

SYSTEM DETAIL

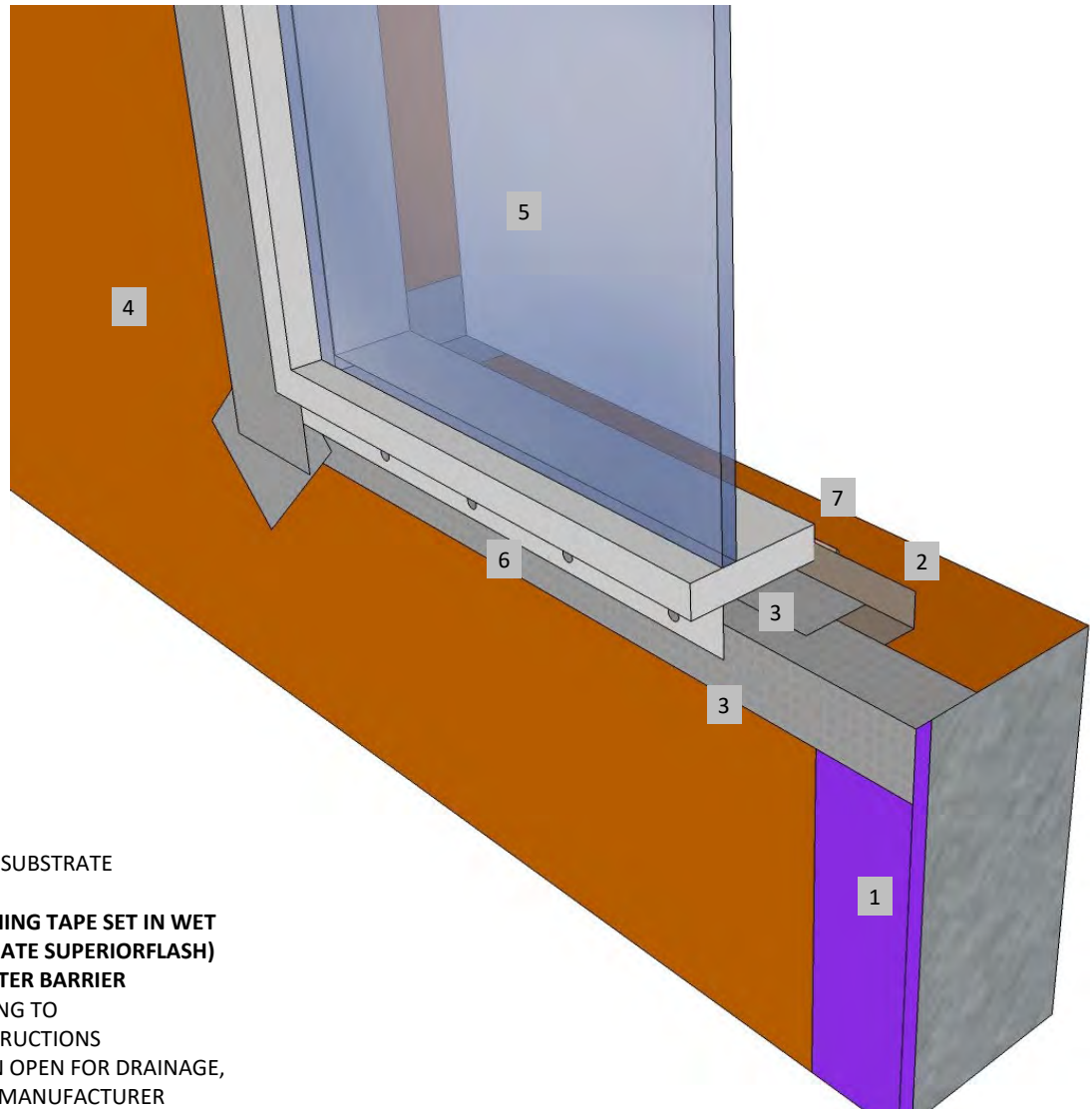

1. FRAMING & APPROVED SUBSTRATE
2. SILL STOP
3. SUPERIORSHIELD FLASHING TAPE SET IN WET ROLLERSHIELD (ALTERNATE SUPERIORFLASH)
4. ROLLERSHIELD AIR/WATER BARRIER
5. WINDOW SET ACCORDING TO MANUFACTURERS' INSTRUCTIONS
6. LOWER FLANGE SHOWN OPEN FOR DRAINAGE, VERIFY WITH WINDOW MANUFACTURER
7. INTERIOR SEALANT

RSLAB-16 TYPICAL WINDOW SILL STOP

M Master Wall Inc.®
Building a Culture of Excellence

PO Box 397 · Fortson · GA · 31808 · 800-755-0825 · masterwall.com

These drawings relay the conceptual conditions of Master Wall® Systems and are not the construction drawings. Ultimately the design and detailing of an entire wall system is the responsibility of a professional. These details will guide the design professional in the use of Master Wall® Products. Master Wall disclaims design, warranty or construction intent or responsibility. Bold or Brand Name = Master Wall® Product. ©2025 Master Wall Inc.®



Master Wall Inc.®
Building a Culture of Excellence

ROLLERSHIELD LAB

SYSTEM DETAIL

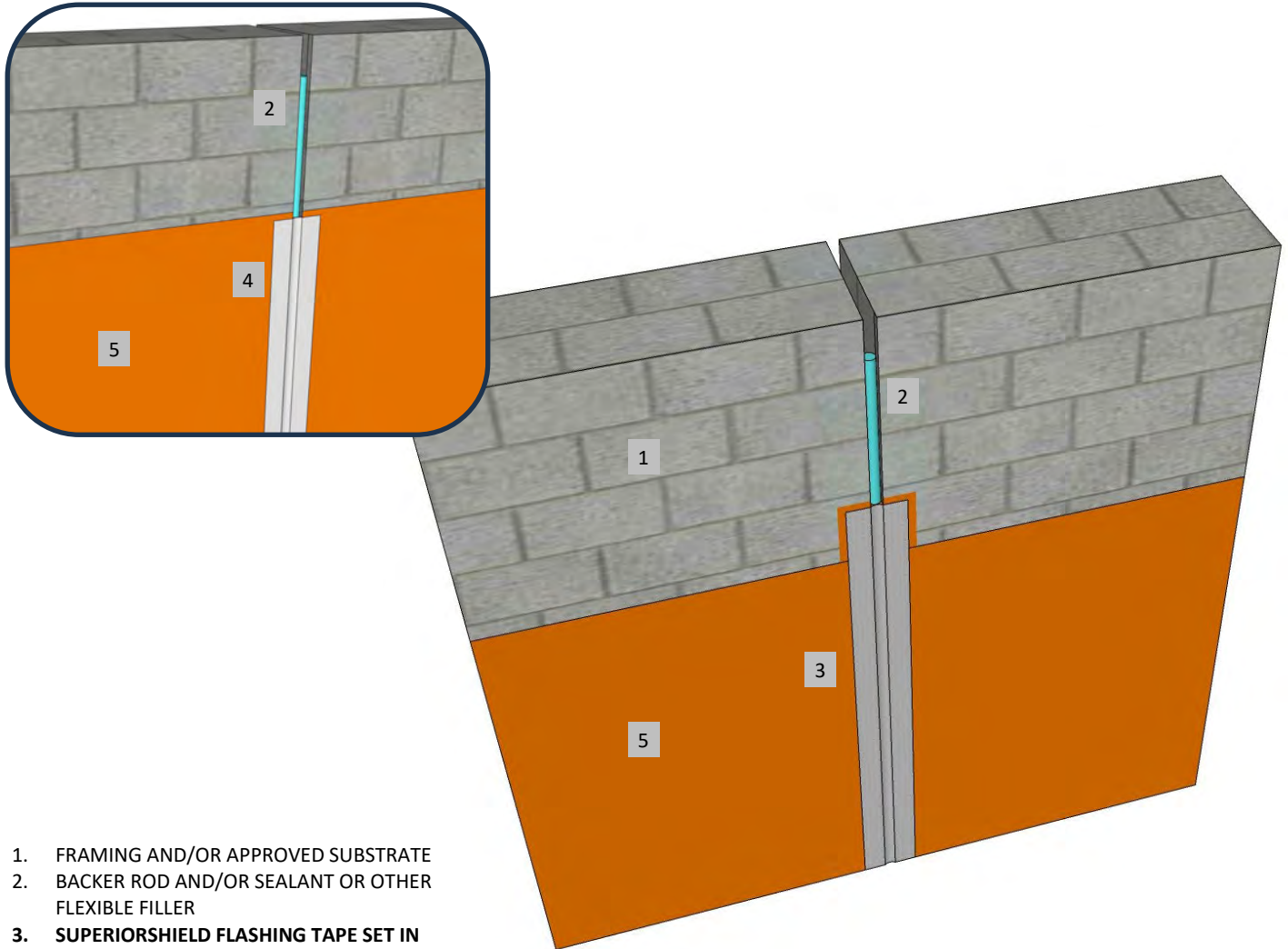

1. FRAMING AND/OR APPROVED SUBSTRATE
2. BACKER ROD AND/OR SEALANT OR OTHER FLEXIBLE FILLER
3. SUPERIORSHIELD FLASHING TAPE SET IN WET ROLLERSHIELD AND TOP COATED WITH ROLLERSHIELD (ALTERNATE SUPERIORFLASH)
4. SUPERIORSHIELD WEATHERSTOP TAPE OPTION
5. ROLLERSHIELD AIR/WATER BARRIER

RSLAB-17 TYPICAL BUILDING EXPANSION OR CONTROL JOINT

M Master Wall Inc.®
Building a Culture of Excellence

PO Box 397 · Fortson · GA · 31808 · 800-755-0825 · masterwall.com

These drawings relay the conceptual conditions of Master Wall® Systems and are not the construction drawings. Ultimately the design and detailing of an entire wall system is the responsibility of a professional. These details will guide the design professional in the use of Master Wall® Products. Master Wall disclaims design, warranty or construction intent or responsibility. Bold or Brand Name = Master Wall® Product. ©2025 Master Wall Inc.®



Master Wall Inc.
Building a Culture of Excellence

ROLLERSHIELD LAB

SYSTEM DETAIL

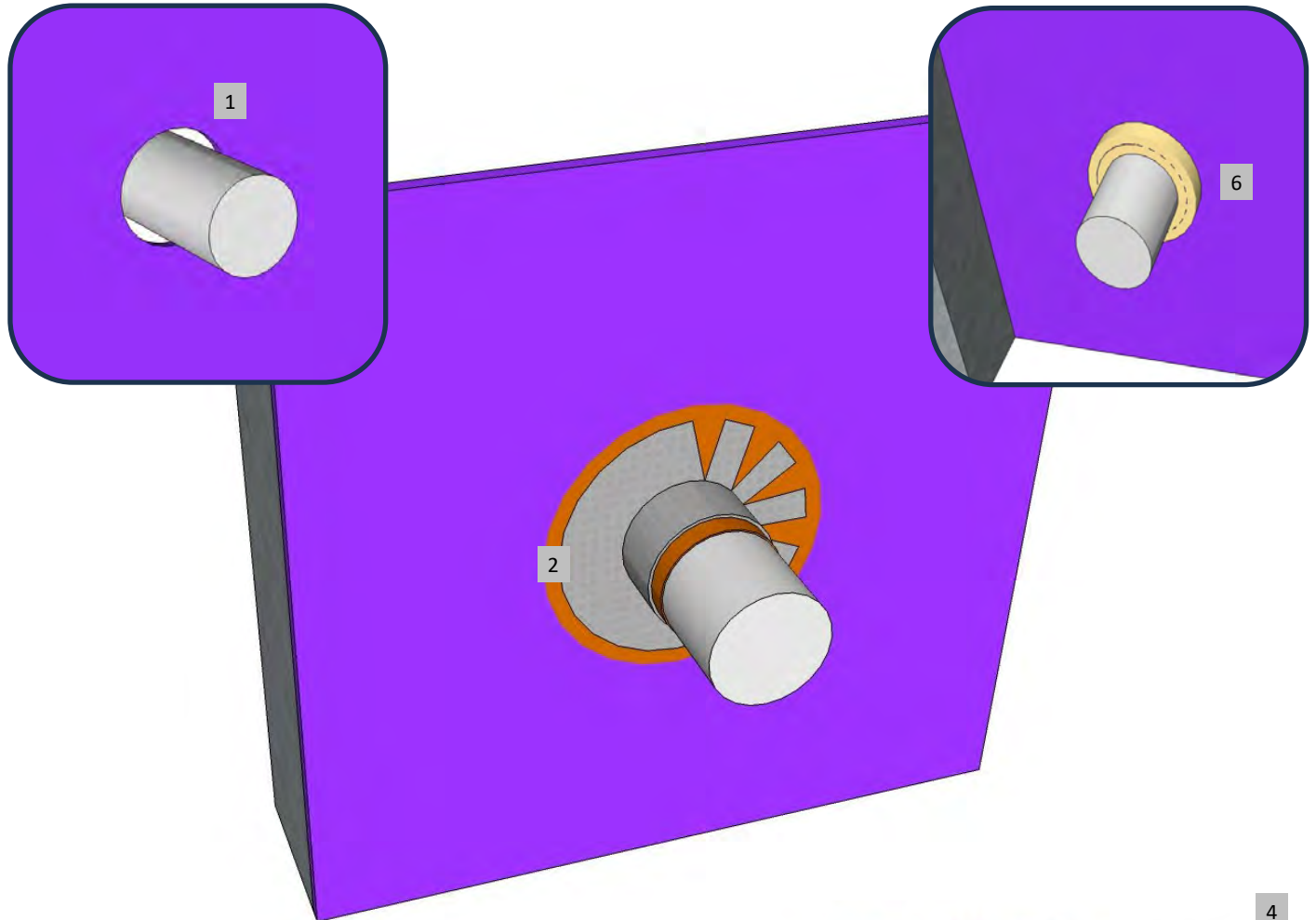

1. SECURED PIPE IN OPENING
2. SUPERIORSHIELD FLASHING TAPE SET IN WET ROLLERSHIELD, TYPICALLY 6X THE PIPE DIAMETER WILL BE REQUIRED FOR PROPER EMBEDMENT (ALTERNATE SUPERIORFLASH AT THIS LOCATION)
3. ROLLERSHIELD FLASHING TAPE CUT AS SHOWN
4. PIPE SIDE OF FLASHING
5. WALL SIDE OF FLASHING
6. INTERIOR SEALANT

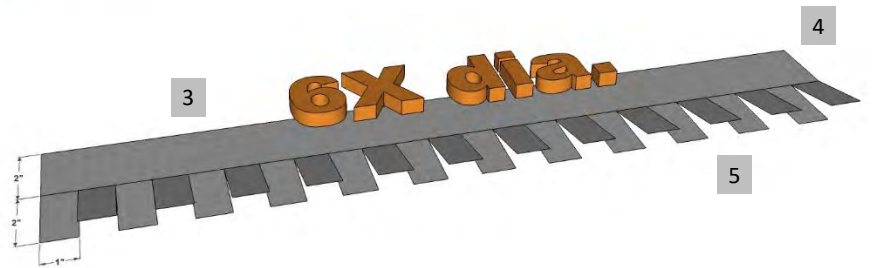

RSLAB-18 TYPICAL PIPE PENETRATION

Master Wall Inc.
Building a Culture of Excellence

PO Box 397 · Fortson · GA · 31808 · 800-755-0825 · masterwall.com

These drawings relay the conceptual conditions of Master Wall® Systems and are not the construction drawings. Ultimately the design and detailing of an entire wall system is the responsibility of a professional. These details will guide the design professional in the use of Master Wall® Products. Master Wall disclaims design, warranty or construction intent or responsibility. Bold or Brand Name = Master Wall® Product. ©2025 Master Wall Inc.®



Master Wall Inc.
Building a Culture of Excellence

ROLLERSHIELD LAB

SYSTEM DETAIL

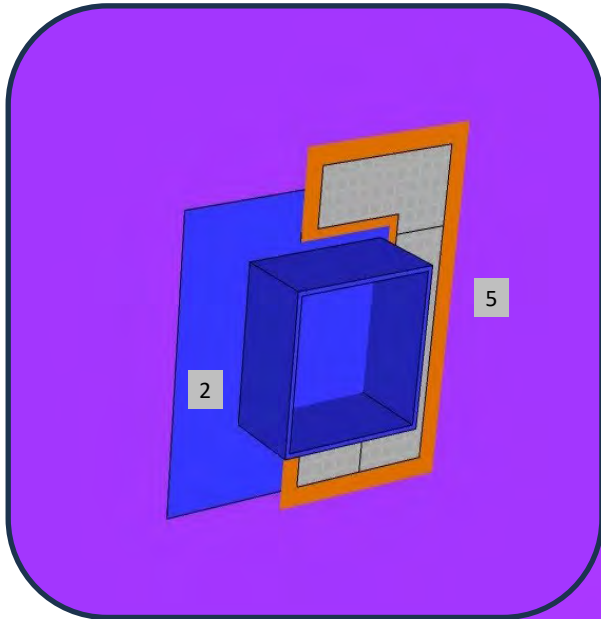

1. WATERPROOF WALL BOX
2. FLANGED WATERPROOF WALL BOX
3. FILL GAPS WITH APPROPRIATE FILLER AS NEEDED
4. ROLLERSHIELD WITH ROLLERSHIELD FLASHING TAPE FLASHED ONTO BOX WALL. CUT ROLLERSHIELD FLASHING TAPE AT LEAST 4" (102 MM) LARGER THAN BOX OPENING AND WRAP IN FOUR INDIVIDUAL PIECES
5. ROLLERSHIELD WITH ROLLERSHIELD FLASHING TAPE FLASHED ONTO BOX WALL. CUT ROLLERSHIELD FLASHING TAPE CUT STRIPS TO WRAP CONTINUOUSLY AND FILL ANY PINHOLES WITH ROLLERSHIELD (ALTERNATE SUPERIORFLASH)
6. INTERIOR SEALANT

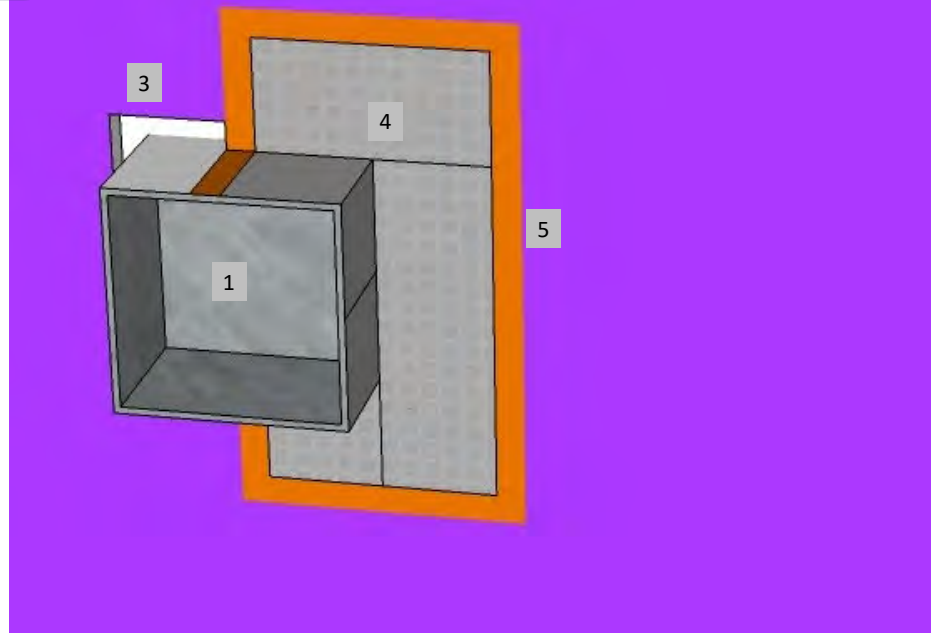

RSLAB-19 WATERPROOF BOX

M Master Wall Inc.
Building a Culture of Excellence

PO Box 397 · Fortson · GA · 31808 · 800-755-0825 · masterwall.com

These drawings relay the conceptual conditions of Master Wall® Systems and are not the construction drawings. Ultimately the design and detailing of an entire wall system is the responsibility of a professional. These details will guide the design professional in the use of Master Wall® Products. Master Wall disclaims design, warranty or construction intent or responsibility. Bold or Brand Name = Master Wall® Product. ©2025 Master Wall Inc.®



Master Wall Inc.
Building a Culture of Excellence

ROLLERSHIELD LAB

SYSTEM DETAIL

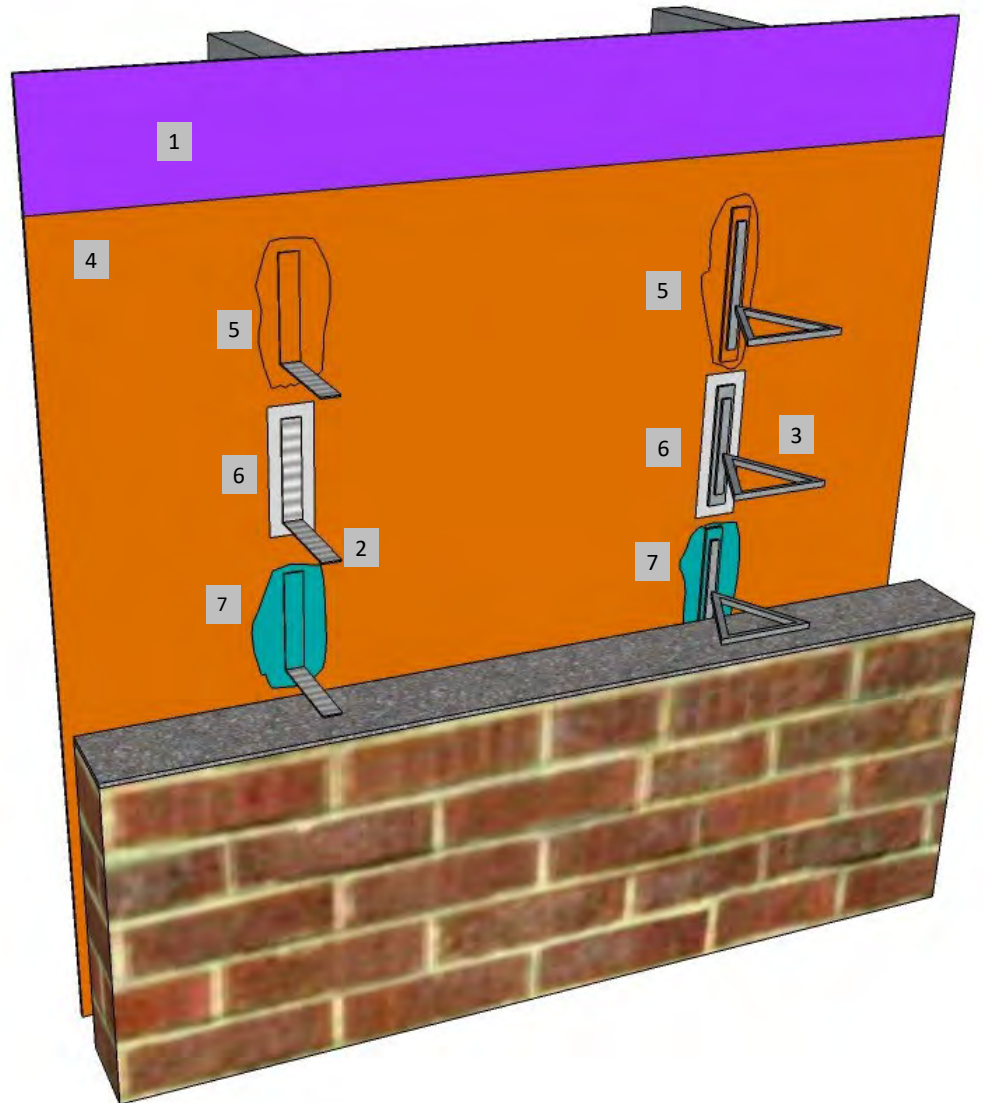

1. FRAMING & APPROVED SUBSTRATE
2. CORRUGATED BRICK TIE
3. SLIP OR INSULATED BRICK TIE
4. ROLLERSHIELD AIR/WATER BARRIER
5. SEAL WITH ROLLERSHIELD
6. SEAL WITH WEATHERSTOP TAPE OR PEEL & STICK
7. SEAL WITH SUPERIORFLASH OR SUPERIORSHIELD SMP SEALANT

RSLAB-20 BRICK TIE

M Master Wall Inc.
Building a Culture of Excellence

PO Box 397 · Fortson · GA · 31808 · 800-755-0825 · masterwall.com

These drawings relay the conceptual conditions of Master Wall® Systems and are not the construction drawings. Ultimately the design and detailing of an entire wall system is the responsibility of a professional. These details will guide the design professional in the use of Master Wall® Products. Master Wall disclaims design, warranty or construction intent or responsibility. Bold or Brand Name = Master Wall® Product. ©2025 Master Wall Inc.®



Master Wall Inc.®
Building a Culture of Excellence

ROLLERSHIELD LAB

SYSTEM DETAIL

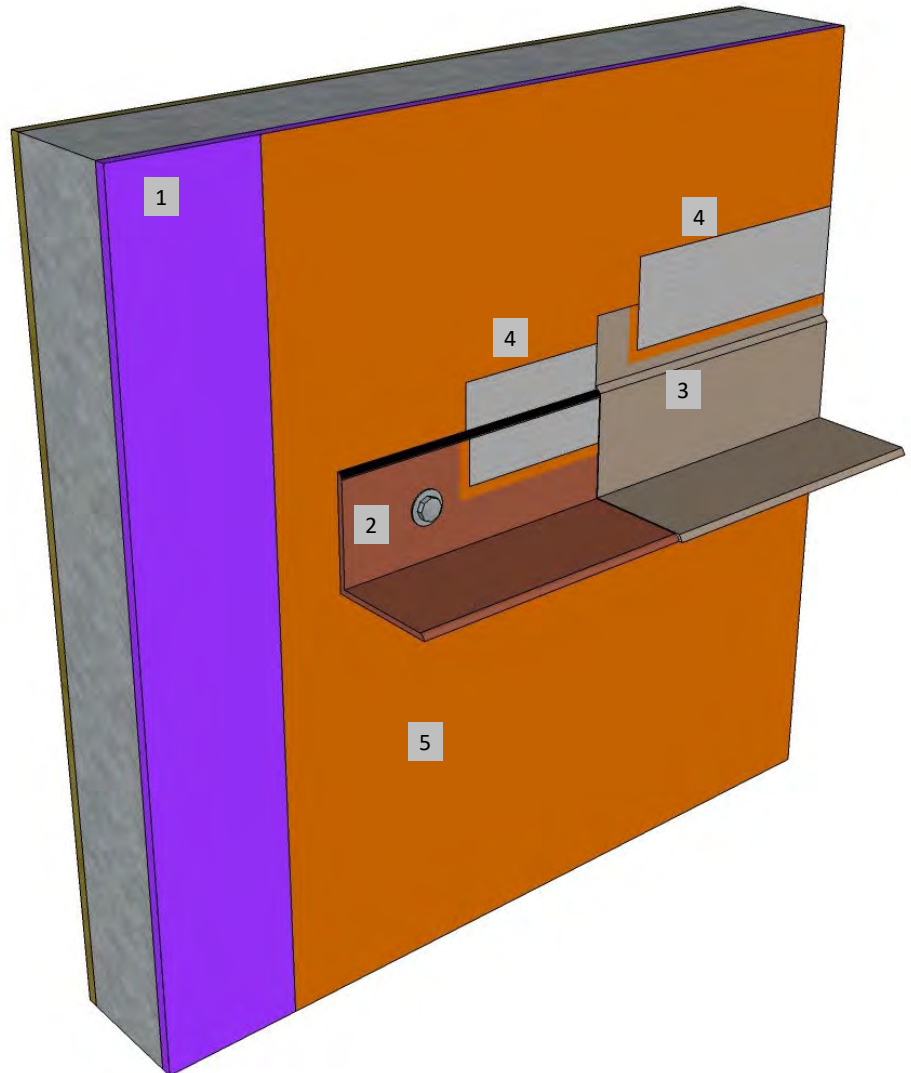

1. FRAMING & APPROVED SUBSTRATE
2. SHELF ANGLE
3. FLASHING
4. SUPERIORSHIELD FLASHING TAPE SET IN WET ROLLERSHIELD (ALTERNATE SUPERIORFLASH)
5. ROLLERSHIELD AIR/WATER BARRIER

RSLAB-21 STRUCTURAL ANGLE

M Master Wall Inc.®
Building a Culture of Excellence

PO Box 397 · Fortson · GA · 31808 · 800-755-0825 · masterwall.com

These drawings relay the conceptual conditions of Master Wall® Systems and are not the construction drawings. Ultimately the design and detailing of an entire wall system is the responsibility of a professional. These details will guide the design professional in the use of Master Wall® Products. Master Wall disclaims design, warranty or construction intent or responsibility. Bold or Brand Name = Master Wall® Product. ©2025 Master Wall Inc.®



Master Wall Inc.®
Building a Culture of Excellence

ROLLERSHIELD LAB

SYSTEM DETAIL

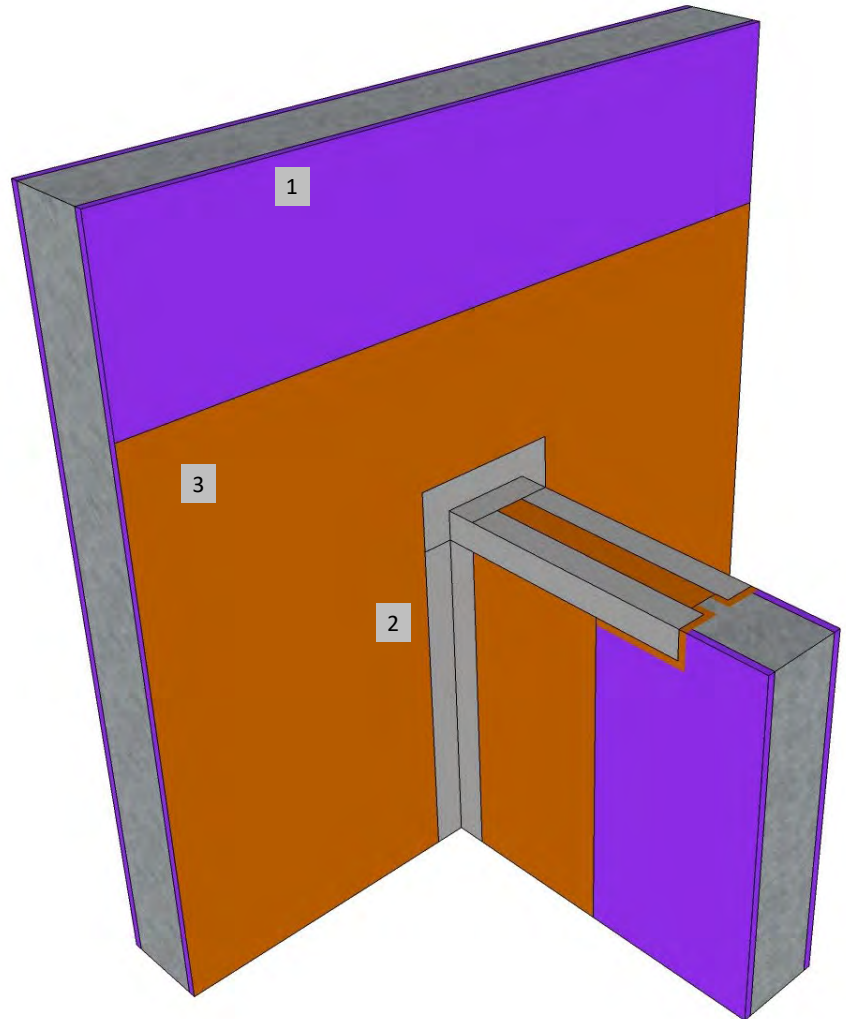
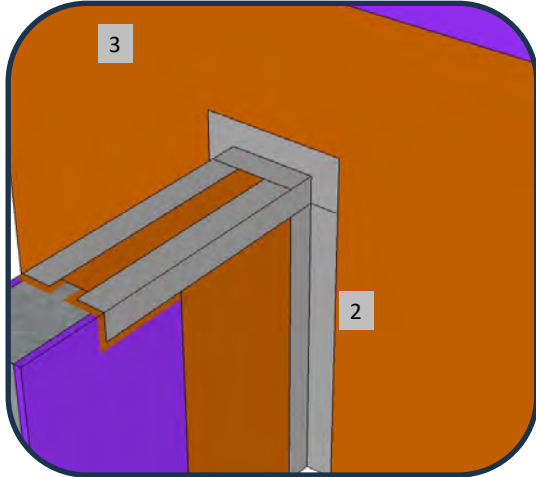

1. FRAMING & APPROVED SUBSTRATE
2. SUPERIORSHIELD FLASHING TAPE SET IN WET ROLLERSHIELD (ALTERNATE SUPERIORFLASH)
3. ROLLERSHIELD AIR/WATER BARRIER

RSLAB-22 SADDLE WALL

M Master Wall Inc.®
Building a Culture of Excellence

PO Box 397 · Fortson · GA · 31808 · 800-755-0825 · masterwall.com

These drawings relay the conceptual conditions of Master Wall® Systems and are not the construction drawings. Ultimately the design and detailing of an entire wall system is the responsibility of a professional. These details will guide the design professional in the use of Master Wall® Products. Master Wall disclaims design, warranty or construction intent or responsibility. Bold or Brand Name = Master Wall® Product. ©2025 Master Wall Inc.®



Master Wall Inc.®
Building a Culture of Excellence

ROLLERSHIELD LAB

SYSTEM DETAIL

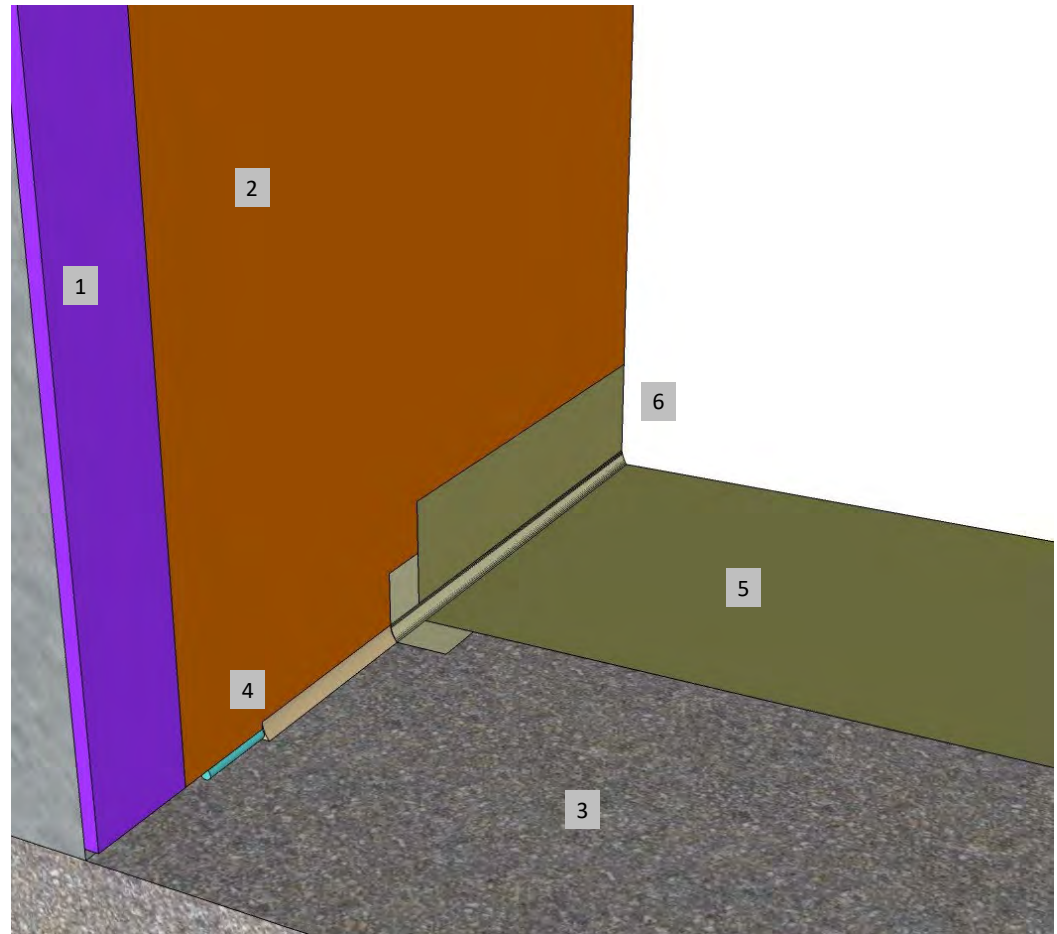

1. FRAMING & APPROVED SUBSTRATE
2. **ROLLERSHIELD AIR/WATER BARRIER**
3. CONCRETE SUBSTRATE
4. TOPPING MANUFACTURER APPROVED SEALANT AND BACKER ROD (DESIGNS VARY)
5. COMPATIBLE WATERPROOF TOPPING
6. EXTEND TOPPING 4" (102 MM) MIN. UP WALL

RSLAB-23 DECK TERMINATION

M Master Wall Inc.®
Building a Culture of Excellence

PO Box 397 · Fortson · GA · 31808 · 800-755-0825 · masterwall.com

These drawings relay the conceptual conditions of Master Wall® Systems and are not the construction drawings. Ultimately the design and detailing of an entire wall system is the responsibility of a professional. These details will guide the design professional in the use of Master Wall® Products. Master Wall disclaims design, warranty or construction intent or responsibility. Bold or Brand Name = Master Wall® Product. ©2025 Master Wall Inc.®



Master Wall Inc.®
Building a Culture of Excellence

ROLLERSHIELD LAB

SYSTEM DETAIL



1. FRAMING & APPROVED SUBSTRATE
2. ROLLERSHIELD AIR/WATER BARRIER
3. SUPERIORSHIELD FLASHING TAPE SET IN WET ROLLERSHIELD (ALTERNATE SUPERIORFLASH)
4. WEATHERSTOP TAPE
5. SHEET WATER BARRIER

RSLAB-24 TRANSITION TO SHEET WATER BARRIER

M Master Wall Inc.®
Building a Culture of Excellence

PO Box 397 · Fortson · GA · 31808 · 800-755-0825 · masterwall.com

These drawings relay the conceptual conditions of Master Wall® Systems and are not the construction drawings. Ultimately the design and detailing of an entire wall system is the responsibility of a professional. These details will guide the design professional in the use of Master Wall® Products. Master Wall disclaims design, warranty or construction intent or responsibility. Bold or Brand Name = Master Wall® Product. ©2025 Master Wall Inc.®



Master Wall Inc.®
Building a Culture of Excellence

ROLLERSHIELD LAB

SYSTEM DETAIL

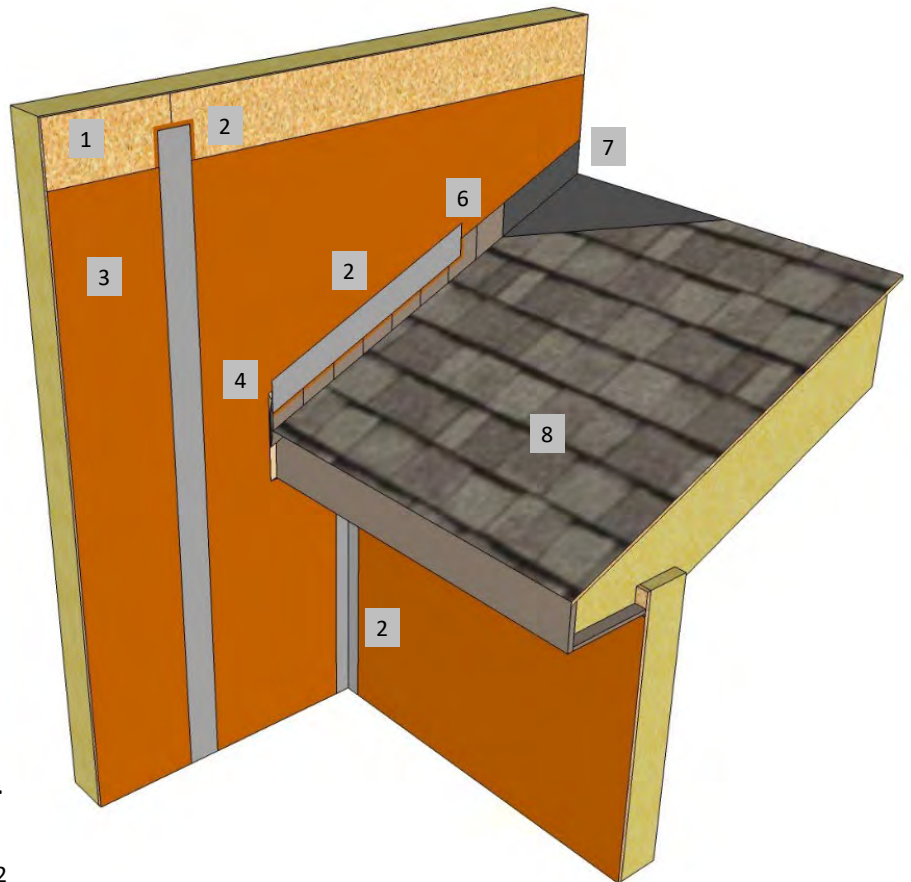
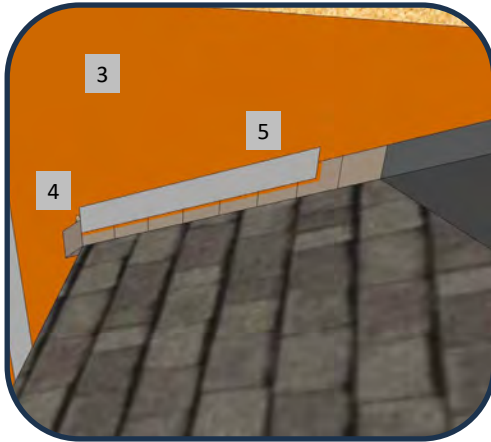

1. FRAMING & APPROVED SUBSTRATE
2. SUPERIORSHIELD FLASHING TAPE SET IN WET ROLLERSHIELD (ALTERNATE SUPERIORFLASH)
3. ROLLERSHIELD AIR/WATER BARRIER
4. KICK OUT FLASHING ANGLE KICK-OUT FLASHING 100° MINIMUM TO ALLOW FOR DRAINAGE. KICK OUT FLASHING SEAMS MUST BE SOLDERED OR SEALED WITH APPROPRIATE SEALANT
5. ROLLERSHIELD SHOULD COVER THE STEP FLASHING A MINIMUM OF 2" (51 MM) AND SIDING SHOULD BE PLACED ABOUT 1" TO 2" (25-51 MM) ABOVE THE ROOFLINE IN ACCORDANCE WITH LOCAL REQUIREMENTS.
6. ROOF STEP FLASHING, EXTEND UP SIDEWALL 4" (102 MM) MIN.
7. ROOFING FELT, EXTEND UP SIDEWALL 4" (102 MM) MIN.
8. ROOF SYSTEM: ROOF SHINGLES (07300), ROOF FELT TURNED UP WALL 4" (102 MM) MIN, ROOF STEP FLASHING AND DRIP EDGE

RSLAB-25 TYPICAL ROOF/WALL INTERSECTION

M Master Wall Inc.®
Building a Culture of Excellence

PO Box 397 · Fortson · GA · 31808 · 800-755-0825 · masterwall.com

These drawings relay the conceptual conditions of Master Wall® Systems and are not the construction drawings. Ultimately the design and detailing of an entire wall system is the responsibility of a professional. These details will guide the design professional in the use of Master Wall® Products. Master Wall disclaims design, warranty or construction intent or responsibility. Bold or Brand Name = Master Wall® Product. ©2025 Master Wall Inc.®



Master Wall Inc.®
Building a Culture of Excellence

ROLLERSHIELD LAB

SYSTEM DETAIL

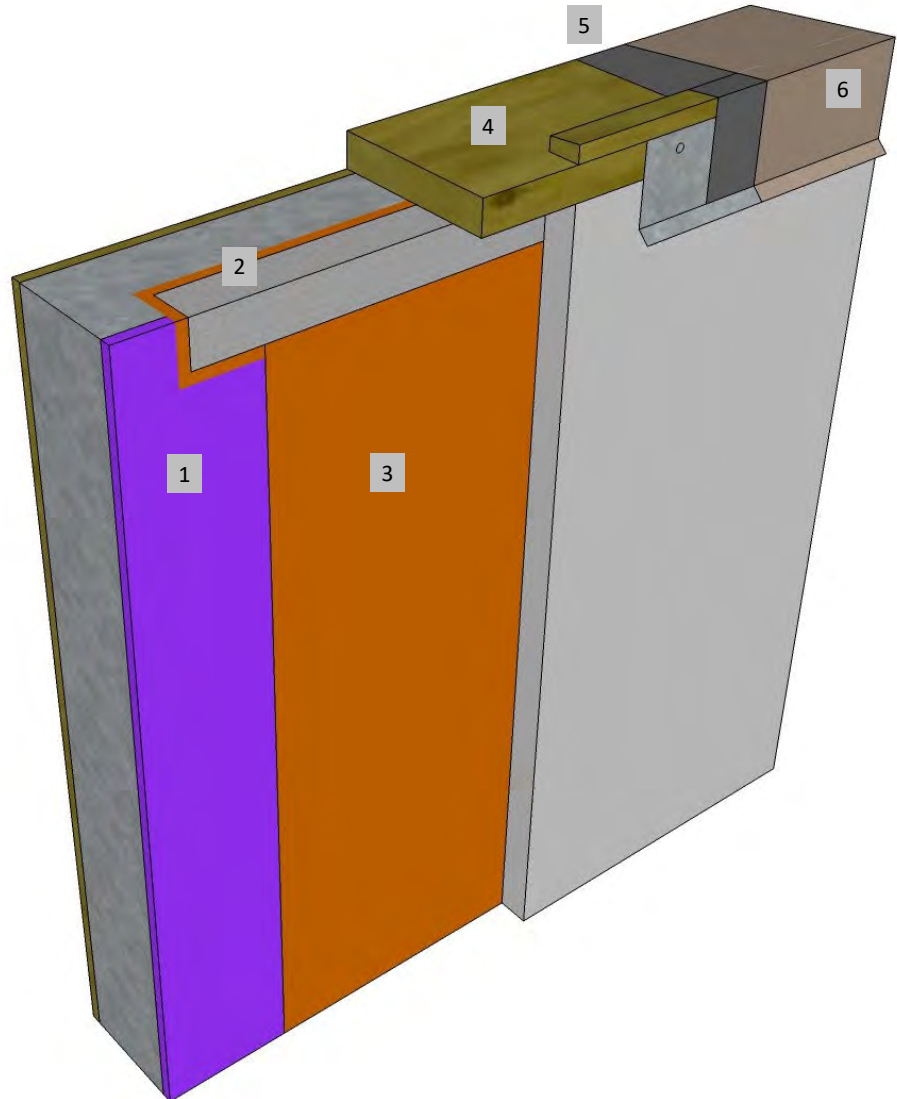

1. FRAMING & APPROVED SUBSTRATE
2. SUPERIORSHIELD FLASHING TAPE SET IN WET ROLLERSHIELD (ALTERNATE SUPERIORFLASH)
3. ROLLERSHIELD AIR/WATER BARRIER
4. TREATED NAILER
5. ROOFING – EXTEND OVER CONTINUOUS CLEAT
6. COPING CAP WITH CONTINUOUS CLEAT – EXTEND 2" (51 MM) MIN OVER EIFS AND STUCCO AND SEAL LOWER EDGE. FOLLOW MANUFACTURER'S RECOMMENDATIONS FOR OTHER SIDING MATERIALS

RSLAB-26 ROOF CAP

M Master Wall Inc.®
Building a Culture of Excellence

PO Box 397 · Fortson · GA · 31808 · 800-755-0825 · masterwall.com

These drawings relay the conceptual conditions of Master Wall® Systems and are not the construction drawings. Ultimately the design and detailing of an entire wall system is the responsibility of a professional. These details will guide the design professional in the use of Master Wall® Products. Master Wall disclaims design, warranty or construction intent or responsibility. Bold or Brand Name = Master Wall® Product. ©2025 Master Wall Inc.®



Master Wall Inc.®



Rollershield-VB

Systems

Rollershield Drainage CIFS®¹
SuperiorShield LAB
Cemplaster Fiberstucco
Common Cladding Systems
¹ properly designed

VOC: <1% by Weight
VOC: <50 g/l
Manufacture Locations:
30058 • 77474 • 84651

Vapor Impermeable
Class I Vapor Retarder

Packaging: 5 gallon (19L) pail

Pail Weight: 55 lbs (25 kg)

Shelf Life: 2 years

Coverage (estimated per pail)

Roller: 225-250 sf (21-23 sm)

Trowel: 100-125 sf (9-11.6 sm)

Spray: 150-175 sf (14-16 sm)

Coverage with 2-coats

Dry to Touch: 1 hour @ room temperature

Recoat Time: 2 hours @ room temperature

Drying Time: 12 hours @ room temperature

Application Range: 40°-110°F (5°-43°C)

Exposure: Up to 6 months

Shelf Life: 2 years

SuperiorShield Rollershield-VB is the vapor barrier version of our Rollershield Liquid applied Air/Water Barrier (LAB). Rollershield-VB is a high quality roll applied flexible air and water barrier. Easily applied with a trowel, brush, roller, hopper gun or airless sprayer. Rollershield-VB forms a continuous air, water, and vapor barrier that protects approved substrates from incidental water damage.

- **100% Coverage**
- **Class I Vapor Retarder**
- **Vapor impermeable, 0.07 perms**
- **Doesn't rattle in the wind**
- **Used as water barrier and flashing**
- **Compatible with Rollershield-RS, Rollershield-TG, SuperiorFlash and Weather-STOP Tape (also Vapor Impermeable)**
- **Adheres to most common building materials**
- **Easy to apply, water based for easy cleanup**
- **Low VOC**

Product Test Standards

ASTM C297/E2134, ASTM D2247, ASTM E72, ASTM E84, ASTM E96 (0.07 perms @ 19-25 mils - desiccant method, 1.35 perms wet method), ASTM E331, ASTM E1233, ASTM E2178 (0.00002 cfm/ft²), ASTM E2357 (0.003 L/s·m² @ 75 Pa, 0.02 L/s·m² @ 300 Pa), ASTM E2485, AATCC 127, ICC ES (AC 212), NFPA 285



Master Wall Inc.®

Building a Culture of Excellence

masterwall.com

PO Box 397 • Fortson • GA • 31808 • 800-755-0825



Rollershield-VB

Temp: 40°-110°F (5°-43°C) • Dry to Touch: 1 hour • Dry Time: 12 hrs
at room temperature, working and drying time will vary with temperature and humidity

Application Procedure

Job Conditions - Air and substrate temperature for application of Rollershield-VB must be 40°F (5°C) or higher and must remain 40°F (5°C) or higher for a minimum of 24 hours. Provide temporary protection to protect the wall system from damage until permanent flashings, caps and sealants are installed. Store materials within prescribed temperature limits and out of direct sunlight. Working and drying times are based upon normal room temperature conditions and will vary with temperature and humidity.

Preparation - The substrate must be approved by Master Wall Inc., clean, dry, structurally sound and free of efflorescence, oil, grease, form release agents and curing compounds or anything that would affect bond. Painted surfaces are not acceptable and must be removed. Substrates must be flat and free of fins or planar irregularities greater than 1/4" in 10'-0" (6.35 mm in 3.05m).

Concrete - Must have cured a minimum of 28 days prior to the application of Rollershield-VB. If form release agents or curing compounds exist on the surface, they must be removed with a solution of muriatic acid or similar product (with appropriate precautions). Remove any residual acid by flushing with water.

Brick/Masonry - If joints are not struck flush, multiple coats may be required. Contact Master Wall for more information.

Sheathing Applications - Sheathing gaps must be less than 1/4" (6.4 mm). For gaps larger than 1/4" (6.4 mm) WeatherStop Tape or SuperiorShield Flashing Tape may be used. Gap wood-based sheathing per manufacturers recommendations, typically 1/8" (3.2 mm) minimum.

Mixing - Thoroughly stir Rollershield-VB into a homogenous consistency. Do not add water, over mix, or add accelerators or retarders to Rollershield-VB.

Application - Rollershield-VB is applied by first treating the joints and fastener locations where sheathing is used, then coating the entire surface with 2-coats of 15-mils wet (10 mils dry) using brush, roller, trowel or airless spray equipment techniques. When using a foam roller, a maximum 3/4" (19 mm) nap is recommended. Apply Rollershield-VB in an even, continuous coat, maintaining a wet edge of approximately 15 mils thickness. For moisture protection, Rollershield-VB must be applied as a continuous barrier of 20 mils dry thickness with no breaks or skips, although some areas will appear lighter than others due to the application process. The Rollershield-VB application need not look like a painted surface.

Joint Treatment—Apply a thin layer of Rollershield-VB to the joints and embed SuperiorShield Flashing Tape into the wet mixture and trowel smooth.

Rollershield-VB may be flashed into window, door and other openings using the same techniques for sheathing applications. Any remaining gaps should be filled with Rollershield-VB and Flashing Tape.

Wall Treatment—Apply Rollershield-VB to the wall surface using the foam roller, trowel or by spray applying and backrolling to a uniform thickness of 20 mils with no pinholes or voids.

Clean Up—Tools and equipment can be cleaned with soapy water when Rollershield-VB is wet.

Limitations: 1. Not for use as an exterior finish. 2. Do not use Rollershield-VB where Rollershield will provide satisfactory performance. 3. Avoid forming a double vapor barrier such as using Rollershield-VB with thick insulation board or insulation boards that are vapor barriers. 4. Do not install vapor barriers on both sides of assemblies - i.e. "double vapor barriers" in order to facilitate assembly drying in at least one direction. 5. Design the vapor barrier for placement on the warm side of the wall. 6. Avoid installation of interior vapor barriers such as polyethylene vapor barriers, foil faced batt insulation and reflective radiant barrier foil insulation on the interior of air-conditioned assemblies. 7. Do not install vinyl wall coverings on the inside of air-conditioned exterior wall assemblies. 8. Enclosures should be ventilated to meet ASHRAE Standard 62.2 or 62.1. Limitations. 9. When adhering Rollershield Drainage CIFS® to the surface assure it is clean, dry and free of surface contamination. Remove any dirt or surface contamination before adhesive attachment. 10. Allowable in-service temperature range: -40° to 180°F (-40° to 82°C). 11. Fire-retardant or pressure treated plywood must be dry with surface free of salts or other chemicals migrating from within the wood. Test adhesion to be sure of desired results. 12. Use a slip sheet, typically one layer of building paper between Rollershield-TG and stucco or adhered masonry veneer over metal lath.

Approved Substrates

Exterior gypsum sheathing (ASTM C1396)
Glass Fiber Exterior Sheathing (ASTM C1177) *Dens Glass Gold®, GlasRoc®*
FiberBond®, Gold Bond e2xp®, etc.
Cement Board Substrates
Durock®, PermaBase®, ProTEC®, SelectCrete, Util-A-Crete®, etc.
Concrete
Brick
Masonry
Exterior Plywood
Oriented Strand Board
Others approved in writing

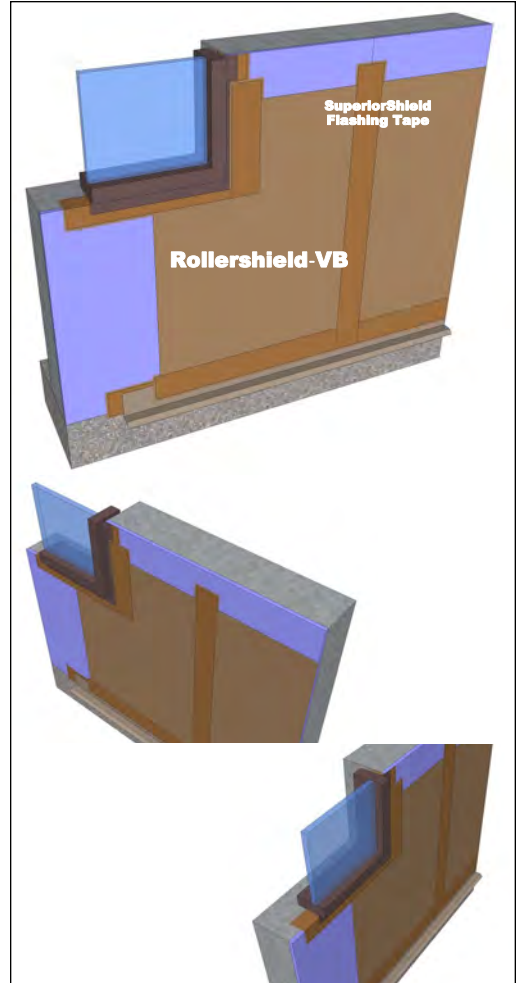

Spray Application

Rollershield-VB is compatible with GRACO and Titan airless spray equipment with the following specifications:

- Minimum 1 gallon per minute output.
- Minimum hose width of 3/8 inch.
- Minimum tip size of 0.027–0.031.

Minimum pressure requirement to spray of 2,000 psi at the gun with an airless sprayer rated no lower than 3,300 psi. Remove all filters in sprayer and gun before application.

Hopper Gun: 3/16"-1/4" (6-6.5 mm) orifice, 23-25 psi.

Information contained in this product data sheet conforms to the standard detail recommendations and specifications for the installation of Master Wall Inc.® products and is presented in good faith. Master Wall Inc.® assumes no liability, expressed or implied as to the architecture, engineering, or workmanship of any project. This information may be concurrent with, or superseded by other applicable documents, such as specifications and details. Contact Master Wall Inc.® for the most current product information. ©2019 Master Wall Inc.®



PO Box 397 • Fortson • GA • 31808 • 800-755-0825



Master Wall Inc.
Building a Culture of Excellence

PRODUCT DATA

SUPERIORSHIELD FLASHING TAPE

Lightweight non adhesive roll flashing material with superior strength and the ability to bridge most gaps or voids common in construction. Embedded into wet Rollershield-RS, TG or VB, it is used at flashing transitions with Master Wall® SuperiorShield Liquid Air/Water Barrier (LAB) and as part of Rollershield Drainage CIFS® applications. The tape easily embeds into wet Rollershield and dries to a highly reinforced yet flexible flashing.

FEATURES & BENEFITS

- Lightweight
- Strong
- Embeds easily
- Thin, will not build up wall surface
- Compatible with Rollershield RS, TG, VB and SuperiorFlash products

JOB CONDITIONS

Air and substrate temperature for application of SuperiorShield Flashing Tape must be 40°F (5°C) or higher. Follow Rollershield-RS, TG or VB temperatures and condition requirements.

PREPARATION

General—The substrate must be clean, dry, structurally sound, and free of efflorescence, oil, grease, form release agents and curing compounds. Test painted surfaces to verify bond.

Temporary Protection – Protect from weather until the Rollershield-RS, TG or VB products have set up.

Surface Preparation - Surface temperature must be above 40°F (5°C). Surface must be cured, clean, dry, structurally sound, and free of efflorescence, oil, grease, form release agents, and curing compounds.

Coverage estimate*

4x8 sheets: Square Footage x 0.37 = linear feet of tape

Add linear footage around windows, doors, and other openings.

**All coverage is approximate and depend upon substrate, details and individual application*

Roll Sizing/Packaging/Shelf Life/Storage

4"x180' (10.2cm x 54.9m)

6"x180' (15.2cm x 54.9m)

9"x180' (22.9cm x 54.9m)

Packaging:

4": 18 rolls per case.

6" & 9": 12 rolls per case.

Shelf Life: 2 years plus

Storage: Protect from extreme heat (90°F (32°C)), and direct sunlight.

APPLICATION PROCEDURE

General - SuperiorShield Flashing Tape is embedded into wet Rollershield-RS, TG or VB at flashing transitions (sheathing to framing, flashing, penetrations, etc.) and at sheathing board joints. Apply a generous layer of the product using a trowel, brush or roller and immediately embed the SuperiorShield Flashing Tape into the product and draw it tight and smooth working from the center to the edges.

Windows – The unique properties of the SuperiorShield air/water barrier system allows window flashing prior to the Rollershield wall application. Apply Rollershield and center SuperiorFlash Flashing Tape to provide at least at least 1" (25 mm) bond to the window flange and substrate on either side of the window opening. Use a "butterfly" at corners to complete the application making sure it covers all corner joints. For best results make sure the Rollershield covers the entire head, jamb, and sill areas. The use of sill wedges or water stops is encouraged.

Sheathing Applications – Apply Rollershield at least 2" (51 mm) either side of the sheathing board joint. Immediately embed the SuperiorShield Flashing Tape into the wet Rollershield and smooth with a trowel, centering it over the joint. Provide at least at least 1" (25 mm) bond either side of the sheathing joint. Lap Rollershield Mesh Tape 2" (51 mm) minimum Rollershield field application can begin as soon as the Rollershield is dry to the touch.

Information contained in this product data sheet conforms to the standard detail recommendations and specifications for the installation of Master Wall Inc.® products and is presented in good faith. Master Wall Inc.® assumes no liability, expressed or implied as to the architecture, engineering, or workmanship of any project. This information may be concurrent with, or superseded by other applicable documents, such as specifications and details. Contact Master Wall Inc.® for the most current product information. ©2022 Master Wall Inc.®



Hazard: This chemical is not considered hazardous according to the OSHA Hazard Communication Standard 2012 (29 CFR 1910.1200).

VOC: Less than 50 g/L.

Approved Materials for Embedment

Rollershield-RS
Rollershield-TG
Rollershield-VB
Others approved in writing

LIMITED WARRANTY

This product is subject to a written limited material or system warranty. Obtain a warranty from the Tech Support tab of our website. Refer to Specifications for more complete information on proper use and handling of this product.

220701



Master Wall, Inc
Building a Culture of Excellence

Rollershield

Liquid Applied Barrier

5 Year Material Limited Warranty

Master Wall Inc. warrants the properly designed and installed Rollershield Liquid Applied Air/Water Barrier and materials for 5 years from the date of installation. Master Wall Inc.'s exclusive liability under this warranty is to supply replacement materials, if it is shown that the materials supplied by Master Wall Inc., were defective when installed by the Master Wall Inc. certified applicator. Remedies shall be solely determined by Master Wall Inc. and no other warranties are expressed or implied. For a valid warranty, the system and products must be installed in accordance with Master Wall Inc.'s written recommendations, specifications, details, bulletins and other project-specific written recommendations. Master Wall Inc. must be notified in writing within 10 business days of the original discovery of the defect.

Master Wall Inc., is not responsible for structural conditions, design conditions beyond those noted in our literature, architecture, engineering or workmanship of any project. Drainage Systems are warranted to drain incidental water for the warranty period. Materials must be properly stored and applied in a timely manner. Workmanship, aesthetics and installation are beyond the scope of this warranty as are any deviations from Master Wall Inc. Documents not specifically approved in writing.

Abuse, misuse, excessive weather or environmental conditions beyond what the products or systems have been tested, designed or approved for is expressly limited. Certain colors with organic pigments are less fade-resistant than others. The building, system and products must be properly maintained in accordance with Master Wall Inc., documents, local environmental conditions and good building practices. In no case is Master Wall Inc. responsible for incidental and consequential damages.

This warranty becomes effective only when all bills for the components of the system have been paid.

Except as stated, Master Wall, Inc., expressly disclaims any warranty of merchantability or fitness for a particular purpose. The above remedies are to be deemed exclusive.

Project:

Applicator:

Warranty Date:

This is not the final warranty. For a valid warranty click on the support tab at masterwall.com and request a warranty. Warranties are not valid until issued.



Rollershield LAB-VB – Liquid-applied Air/Water Barrier Section 07 27 00



Master Wall Inc.®
PO Box 397
Fortson, GA 31808
706-569-0092
800-755-0825
www.masterwall.com

Master Wall Guide Specification RSLABVB Rollershield LAB

PART I – GENERAL

1.01 SUMMARY

A. This document is to be used in preparing specifications for projects utilizing the Master Wall Inc.® Rollershield Liquid-applied Air/Water Barrier (LAB) a 100% acrylic based liquid or fluid applied Class 1 vapor, air and water barrier designed with low VOC and approved where a water barrier or flashing is required. Related Master Wall Inc.® documents:

1. Master Wall Inc.® Rollershield System Data Sheet
2. Master Wall Inc.® Rollershield System Application Instructions
3. Master Wall Inc.® Rollershield System Installation Details
4. Master Wall product data sheets

B. Related Sections

1. Unit Masonry – Section 04200
2. Concrete – Sections 03300 and 03400
3. Light Gauge Cold Formed Steel Framing – Section 05400
4. Wood Framing – Section 06100
5. Sealant – Section 07900
6. Flashing – Section 07600

1.02 SUBMITTALS

- A. Manufacturer's specifications, details, installation instructions and product data
- B. Manufacturer's code compliance report
- C. Manufacturer's standard warranty
- D. Applicator's industry training credentials
- E. Samples for approval as directed by architect or owner
- F. Prepare and submit project-specific details (when required by contract documents)



Rollershield LAB-VB – Liquid-applied Air/Water Barrier

Section 07 27 00

1.03 REFERENCES

A. ASTM Standards:

- ASTM C297 Tensile Bond
- ASTM C1177 Standard Specification for Glass Mat Gypsum Substrate for Use as Sheathing
- ASTM C1396 (formerly C 79) Standard Specification for Gypsum Board
- ASTM D1784 Specification for Rigid Poly (Vinyl Chloride) (PVC) and Chlorinated Poly (Vinyl Chloride) (CPVC) Compounds
- ASTM E84 Standard Test Method for Surface Burning Characteristics of Building Materials
- ASTM E72 Racking Resistance
- ASTM E96 Test Methods for Water Vapor Transmission of Materials
- ASTM E330 Test Method for Structural Performance of Exterior Windows, Doors and Curtain Walls by Uniform Static Air Pressure Difference
- ASTM E331 Test Method for Water Penetration of Exterior Windows, Skylights, Doors and Curtain Walls by Uniform Static Air Pressure Difference.
- ASTM E1233 Structural Performance
- ASTM E2134 Test Method for Evaluating the Tensile-Adhesion Performance of an Exterior Insulation and Finish System (EIFS)
- ASTM E2178 Test Method for Air Permeance of Building Materials
- ASTM E2357 Standard Test Method for Determining Air Leakage of Air Barrier Assemblies
- ASTM E2485 Freeze/Thaw Resistance
- ASTM E2568 Standard Specification for Class PB Exterior Insulation and Finish Systems
- ASTM E2570 Test Method for Water-Resistive (WRB) Coatings used Under Exterior Insulation and Finish Systems (EIFS) with Drainage

B. Building Code Standards

- AC212 Restrained Environmental Cycling, UV Exposure and Aging
- AC235 Acceptance Criteria for EIFS Clad Wall Assemblies (November 2009)

C. National Fire Protection Association (NFPA) Standards

- NFPA 268 Standard Test Method for Determining Ignitibility of Exterior Wall Assemblies Using a Radiant Heat Energy Source
- NFPA 285 Standard Method of Test for the Evaluation of Flammability Characteristics of Exterior Non-Load Bearing Wall Assemblies containing Combustible Components Using the Intermediate-Scale, Multistory Test Apparatus

D. Other Referenced Documents

- American Association of Textile Chemists and Colorists AATCC-127 Water Resistance: Hydrostatic Pressure Test
- APA Engineered Wood Association E30, Engineered Wood Construction Guide
- UES Evaluation Report 384, Rollershield Water Barrier



Rollershield LAB-VB – Liquid-applied Air/Water Barrier

Section 07 27 00

1.04 SYSTEM DESCRIPTION

- A. General: The Master Wall Inc.® Rollershield LAB is a fluid applied vapor, air and water barrier application. The product shall be applied over an approved substrate in accordance with the Rollershield LAB application Details.
- B. Methods of Installation
1. Field Applied: The Rollershield LAB System is applied to the substrate system in place.
 2. Panelized: The Rollershield LAB System is shop-applied to the prefabricated wall panels.
- C. Design Requirements
1. Acceptable substrates for the Rollershield LAB System shall be:
 - a. Exterior sheathing having a water-resistant core with fiberglass mat facers meeting ASTM C 1177.
 - b. Exterior fiber reinforced cement or calcium silicate boards.
 - c. APA Exterior or Exposure 1 Rated Plywood, Grade C-D or better, nominal 12.7 mm (1/2 in), minimum 4-ply.
 - d. Unglazed, unpainted brick, cement plaster, concrete, or masonry.
 - e. APA Exposure 1 rated Oriented Strand Board (OSB) or plywood, nominal 12.7 mm (1/2 in).
 - f. Other substrates approved in writing from the manufacturer.
 2. Deflection of substrate systems shall not exceed 1/240 times the span.
 3. The substrate shall be flat within 6.4 mm (1/4 in) in a 3.05 m (10 ft) radius.
 4. The slope of inclined surfaces shall not be less than 6:12, and the length shall not exceed 305 mm (12 in).
 5. Expansion Joints
 - a. Design and location of expansion joints in the Rollershield LAB System is the responsibility of the project designer and shall be noted on the project drawings. As a minimum, expansion joints shall be placed at the following locations:
 - 1) Where expansion joints occur in the substrate system.
 - 2) Where building expansion joints occur.
 - 3) At floor lines in wood frame construction (Reference Technical Bulletin #140).
 - 4) At floor lines of non-wood framed buildings where significant movement is expected.
 - 5) Where the Rollershield LAB System abuts dissimilar materials.
 - 6) Where the substrate type changes
 - 7) Where prefabricated panels abut one another
 - 8) Where significant structural movement occurs such as changes in roofline, building shape or structural system.
 6. Terminations
 - a. Interior foam expanding foam sealant may be required behind penetration openings.
 - b. Sealants
 - 1) Shall be manufactured and supplied by others.
 - 2) Shall be compatible with Rollershield LAB System materials.
 7. Vapor Retarders and barriers – The use and location of vapor retarders and/or barriers within a wall assembly is the responsibility of the project designer and shall comply with local building code requirements.
 8. Flashing: Shall be provided at all roof-wall intersections, windows, doors, chimneys, decks, balconies and other areas as necessary to prevent water from entering behind the Rollershield LAB System.



Rollershield LAB-VB – Liquid-applied Air/Water Barrier

Section 07 27 00

1.05 PERFORMANCE REQUIREMENTS

A. Rollershield LAB System shall have been tested as follows:

Air/Moisture Barrier Performance

TEST	METHOD	CRITERIA	RESULT
1. Water Penetration Resistance	AATCC 127 (Water Column) ICC ES (AC 212)*	Resist 21.6 in (55 cm) water for 5 hours before and after aging	Pass
2. Water Penetration Resistance after Cyclic Wind Loading	ASTM E1233 / ASTM E331	No water penetration beyond the inner-most plane of the wall after 15 minutes at 137 Pa (2.86 psf)	No water penetration
3. Water Resistance Testing	ASTM D2247 ICC ES (AC 212)*	Absence of deleterious effects after 14-day exposure	Pass: Plywood Cement Board, OSB, Exterior Gypsum (ASTM C79/C1396) and Dens Glass Gold (ASTM C1377) substrates
4. Water Vapor Transmission	ASTM E96 Procedure A - Desiccant Method and Procedure B - Water Method	Measure	0.07 perms Desiccant Method 1.35 perms Water Method
5. Air Leakage (material)	ASTM E2178	≤ 0.004 cfm/ft ² at 1.57 psf (0.02 L/s•m ² at 75 Pa)	0.0002 cfm/ft ²
6. Air Leakage (assembly)	ASTM E2357	≤ 0.04 cfm/ft ² (0.2 L/s•m ²) @ 75 Pa	0.003 L/s.m ² @ 75 Pa 0.02 L/s.m ² @ 300 Pa
7. Racking	ASTM E72 ICC ES (AC 212)*	No cracking in field, at joints or interface with flashing at net deflection of 3.2 mm (1/8 inch)	Pass
8. Freeze-thaw	ASTM E2485/ICC-ES Proc. ICC ES (AC 212)*	No deleterious effects after 10 cycles	Pass: Plywood, Cement Board, OSB, Exterior Gypsum (ASTM C79/C1396) and Dens Glass Gold (ASTM C1377) substrates
9. UV Exposure	ICC ES Proc. ICC ES (AC 212)*	210 hours of exposure, rated for up to 6 months of exposure	Pass
10. Surface Burning	ASTM E84	Flame Spread 0 – 25 for NFPA Class A, UBC Class I	Flame Spread: 5 Smoke Density: 5
11. Tensile Adhesion	ASTM C297	>15 psi (103 kPa)	Dens Glass Gold 31 (215), Exterior Gypsum 28 (194), OSB 40 (277), Plywood 79 (563), Cement Board 70 (485), Copper 185 (1282), Galvanized steel 180 (1248), PVC 168 (1165), Aluminum 184 (1275), Coated Aluminum 203 (1407), Stainless Steel 183 (1269)

* AC212 – Acceptance Criteria for Water-Resistive Coatings Used as Water-Resistive Barriers over Exterior Sheathing, also referred to as ASTM E 2570



Rollershield LAB-VB – Liquid-applied Air/Water Barrier

Section 07 27 00

LAB Weather Resistance and Durability Performance*

TEST	METHOD	CRITERIA	RESULTS
1. Transverse Wind Load	ASTM E330	Withstand positive and negative wind loads as specified by the building code.	Pass. Assemblies vary from 68-287 psf*

* Ultimate wind loads – contact Master Wall for specific assemblies.

Air/Moisture Barrier and LAB Fire Performance

TEST	METHOD	CRITERIA	RESULT
1. Intermediate Scale Multi-Story Fire Test	NFPA 285 (formerly UBC Standard 26-9)	<ol style="list-style-type: none"> 1. Resistance to vertical spread of flame within the core of the panel from one story to the next 2. Resistance to flame propagation over the exterior surface 3. Resistance to vertical spread of flame over the interior surface from one story to the next 4. Resistance to significant lateral spread of flame from the compartment of fire origin to adjacent spaces 	Pass
2. Surface Burning (individual components)	ASTM E84	Individual components shall each have a flame spread of 25 or less, and smoke developed of 450 or less	Flame Spread: 0 Smoke Developed: 0

1.06 QUALITY ASSURANCE

A. Qualifications

1. System Manufacturer: Shall be Master Wall Inc.®. All materials shall be manufactured or sold by Master Wall Inc.® and shall be purchased from Master Wall Inc.® or its authorized distributors.
2. Contractor: Shall be knowledgeable in the proper installation of the Master Wall Inc.® Rollershield LAB System. Additionally, the contractor shall possess a current Master Wall Inc.® applicator certificate issued by Master Wall Inc.®

B. Regulatory Requirements

1. Continuous insulation if used shall be separated from the interior of the building by a minimum 15-minute thermal barrier.
2. The use and maximum thickness of continuous insulation shall be in accordance with the applicable building codes.

C. Certification

1. The Rollershield LAB System shall be recognized for the intended use by the applicable building code(s).

D. Mock-Up

1. The contractor shall, before the project commences, provide the owner/architect with a mock-up for approval.
2. The mock-up shall be of suitable size as required to accurately represent the products being installed, as well as each color and texture to be utilized on the project.
3. The mock-up shall be prepared with the same products, tools, equipment and techniques required for the actual application. The finish used shall be from the same batch that is being used on the project.
4. The approved mock-up shall be available and maintained at the job site.
5. For panelized construction, the mock-up shall be available and maintained at the panel fabrication location.



Rollershield LAB-VB – Liquid-applied Air/Water Barrier

Section 07 27 00

1.07 DELIVERY, STORAGE AND HANDLING

- A. All Master Wall Inc.® materials shall be delivered to the job site in the original, unopened packages with labels intact.
- B. Upon arrival, materials shall be inspected for physical damage, freezing, or overheating. Questionable materials shall not be used.
- C. Deliver all materials in original unopened packages with labels intact. Verify all quantities, colors, and textures against bill of lading.
- D. Store all materials protected from direct exposure to weather conditions and at temperatures not less than 40°F (4°C) or greater than 110°F (43°C).
- E. Material Safety Data Sheets (MSDS) or Safety Data Sheets (SDS) shall be supplied for the components of the LAB and be available at the job site.

1.08 PROJECT CONDITIONS

- A. Ambient air temperatures shall be 40°F (4°C) or greater and rising at the time of installation of the Master Wall Inc.® products and shall remain at 40°F (4°C) or greater for at least 24 hours after application.
- B. Provide supplemental heat and protection as required when the temperature and conditions are not in accordance with installation requirements. Sufficient ventilation and time shall be provided to ensure that materials have sufficiently dried prior to removing supplemental heat.
- C. Adequate protection shall be provided to prevent weather conditions (humidity, temperature, and precipitation) from having an affect on the curing or drying time of Master Wall Inc.® materials.
- D. Adjacent materials and the Rollershield LAB System shall be protected during installation and while curing from weather and shall be protected from site damage.
- E. Coordinate installation of the Rollershield LAB System with related work specified in other sections to ensure that the wall assembly is protected to prevent water from getting behind the system. The cap flashing shall be installed as soon as possible after the finish coat has been applied. When this is not possible, temporary protection shall be provided immediately in this area.
- F. All sealant work shall be installed in a timely manner. Protect open joints from water intrusion during construction with backer rod, or temporary covering, until permanently sealed.
- G. Sufficient manpower and equipment shall be employed to ensure a continuous operation, free of cold joints, scaffolding lines, and texture variations, etc.
- H. Existing Conditions - The contractor shall have access to electric power, clean water, and a clean work area at the location where the Master Wall Inc.® materials are to be applied.
- I. Exposure Limitations – Rollershield LAB is limited to a maximum of six months exposure when Rollershield Drainage EIFS is to be adhered to the product. The surface must be clean and dry prior to application of EIFS. Under all other cladding products, the exposure limitation is a maximum of six months.

1.09 SEQUENCING AND SCHEDULING

- A. Installation of the Rollershield System shall be coordinated with other construction trades.
- B. Sufficient manpower and equipment shall be employed to ensure a continuous operation.

1.10 LIMITED MATERIALS WARRANTY

- A. Provide a manufacturer's warranty against defective material upon request.

1.11 MAINTENANCE

- A. Maintenance and repair shall follow the procedures noted in Master Wall Inc.® Technical Bulletins #112 and #129.



Rollershield LAB-VB – Liquid-applied Air/Water Barrier

Section 07 27 00

PART II – PRODUCTS

2.01 MANUFACTURER

- A. All components of the Rollershield LAB System shall be supplied or obtained from Master Wall Inc.® or its authorized distributors. Substitutions or additions of materials other than specified will void the warranty.

2.02 MATERIALS

- A. Liquid-applied Air/Water Barriers (LAB)
1. Rollershield-VB: A Class I Vapor Retarder with a vapor permeability of 0.07 perms.
- B. Sheathing Joint Treatment/Transition Treatment
1. Rollershield Flashing Tape, 4" (104 mm) width.
- C. SuperiorFlash: Moisture curing gun grade alternate treatment for flashing windows, or joints and seams of the Rollershield LAB application.
- D. Exterior Sealants (Rollershield to Penetrating Item): Single part polyurethane conforming to Federal Specification TT-S-00230C, Type II, Class A; ASTM C 920, Type S, Grade NS, Class 25, Use NT, M, A, G and I.
1. BASF Sonolastic® NP1™
 2. Sikaflex® One Part Polyurethane
 3. Tremco Vulkem Polyurethane Sealant
- E. Interior Sealants: A multi-purpose, professional, low-expansion construction adhesive and gap and crack filler. One component polyurethane foam that cures by absorbing water vapor from the air with no CFC/HCFC.
1. Wind-Lock Foam-2-Foam Adhesive
 2. Illbruck FM230 Window Seal Gun Grade Foam

PART III – EXECUTION

3.01 EXAMINATION

- A. Prior to installation of the Rollershield LAB System, the contractor shall verify that the substrate:
1. Is of a type listed.
 2. Is flat within 6.4 mm (1/4 in) in a 3 m (10 ft) radius.
 3. Is sound, dry, connections are tight, has no surface voids, projections or other conditions that may interfere with the Rollershield LAB installation or performance.
- B. Prior to the installation of the Rollershield LAB System, the architect or general contractor shall insure that all needed flashings and other waterproofing details have been completed, if such completion is required prior to the Rollershield application. Additionally, the Contractor shall ensure that:
1. Metal roof flashing has been installed in accordance with Asphalt Roofing Manufacturers Association (ARMA) Standards.
 2. Openings are flashed in accordance with the Rollershield LAB System Installation Details or as otherwise necessary to prevent water penetration.
 3. Chimneys, Balconies, and Decks have been properly flashed.
 4. Windows, Doors, etc. are installed and flashed per manufacturer's requirements and the Rollershield LAB System Installation Details.
- C. Prior to the installation of the Rollershield LAB System, the contractor shall notify the general contractor, and/or architect, and/or owner of all discrepancies.



Rollershield LAB-VB – Liquid-applied Air/Water Barrier

Section 07 27 00

3.02 PREPARATION

- A. Rollershield LAB materials shall be protected by permanent or temporary means from inclement weather and other sources of damage prior to, during, and following application until completely dry.
- B. Protect adjoining work and property during Rollershield LAB installation.
- C. The substrate shall be prepared as to be free of foreign materials, such as, oil, dust, dirt, form release agents, efflorescence, paint, wax, water repellents, moisture, frost and any other condition that inhibit adhesion.

3.03 GENERAL GUIDELINES

- A. The system shall be installed in accordance with the current Master Wall Inc.® Rollershield LAB System Application Instructions.

3.04 FIELD QUALITY CONTROL

- A. The contractor shall be responsible for the proper application of the Rollershield LAB materials.
- B. Master Wall Inc.® assumes no responsibility for on-site inspections or application of its products.
- C. If required, the contractor shall certify in writing the quality of work performed relative to the substrate system, details, installation procedures, workmanship and as to the specific products used.

3.05 ROLLERSHIELD LAB APPLICATION

- A. Mixing
 - 1. Mix the products following the instructions on the product data sheets.
 - 2. Additives shall not be added to Master Wall Inc.® materials unless written approval has been received from Master Wall Inc.®
- B. Preparation
 - 1. Protect contiguous work from damage during application of the Rollershield LAB. Temporary covering may be required to prevent over spray or splattering of coatings on other work.
 - 2. Protect substrate from inclement weather during installation. Prevent infiltration of moisture behind the wall.
 - 3. Coatings shall not be installed when ambient air temperature is below 40°F (4°C). The temperature shall remain at or above 40°F (4°C) during mixing, application and until materials have dried.
 - 4. Flashings shall be installed as required by construction documents and Master Wall Inc.® details in a manner to prevent the intrusion of water behind the wall system. All flashing materials should direct the water to the exterior face of the finished wall system.
- C. Installation, General
 - 1. Reference architectural details for full wall system requirements.
 - 2. Comply with the manufacturers' current published instructions, (specifications, details, data sheets and technical bulletins) for the installation of the Rollershield LAB.
 - 3. Comply with local building codes.
 - 4. Verify that all flashings and other items are in place.
- D. Rollershield Liquid-applied Air/Water Barrier (LAB) Application
 - 1. The substrate must be approved by Master Wall Inc.®, clean, dry, structurally sound and free of efflorescence, oil, grease, form release agents and curing compounds or anything that would affect bond. Painted surfaces are not acceptable and must be removed. Substrates must be flat and free of fins or planar irregularities greater than 1/4" in 10'-0" (6.35 mm in 3.05m).

Concrete – Must have cured a minimum of 28 days prior to the application of Rollershield LAB. If form release agents or curing compounds exist on the surface, they must be removed with a solution of muriatic acid or similar product (with appropriate precautions). Remove any residual acid by flushing with water.

Brick/Masonry – If joints are not struck flush, multiple coats may be required. Contact Master Wall for more information.

Sheathing Applications - Sheathing gaps must be less than 1/4" (6.4 mm). Gap wood-based sheathing per manufacturer's recommendations, typically 1/8" (3.2 mm) minimum.



Rollershield LAB-VB – Liquid-applied Air/Water Barrier

Section 07 27 00

2. Mixing - Thoroughly stir Rollershield-VB into a homogenous consistency. Do not add water, over mix, or add accelerators or retarders to Rollershield-VB.
 3. Rollershield-VB is applied by first treating the joints and fastener locations where sheathing is used, then coating the entire surface with 2-coats of 15-mils wet (10 mils dry) using brush, roller, trowel or airless spray equipment techniques. When using a foam roller, a maximum ¾" (19 mm) nap is recommended.
 4. Joint Treatment—Apply a thin layer of Rollershield-VB to the joints and embed SuperiorShield Flashing Tape into the wet mixture and trowel smooth.
 5. Rollershield-VB may be flashed into window, door and other openings using the same techniques for sheathing applications. Any remaining gaps should be filled with Rollershield-VB and Flashing Tape.
 6. Apply Rollershield-VB in an even, continuous coat, maintaining a wet edge of approximately 15 mils wet thickness. For moisture protection, Rollershield-VB must be applied as a continuous barrier of 20 mils dry thickness with no breaks or skips, although some areas will appear lighter than others due to the application process. The Rollershield-VB application need not look like a painted surface.
 7. Spray Recommendations: Rollershield is compatible with GRACO and Titan airless spray equipment with the following specifications; Minimum 1 gallon per minute output, Minimum hose width of 3/8 inch, Minimum tip size of 0.027–0.031, Minimum pressure requirement to spray of 2,000 psi at the gun with an airless sprayer rated no lower than 3,300 psi. Remove all filters in sprayer and gun before application. Hopper Gun: 3/16"-1/4" (6-6.5 mm) orifice, 23-25 psi.
 8. Repair any voids or holes with additional coats of Rollershield-VB.
 9. Allow to dry completely before proceeding with installation.
- E. Flashings or Terminations
1. Install flashing terminations as recommended. Apply a thin layer of Rollershield-VB at the transitions. While the Rollershield is still wet, center Rollershield Flashing Tape and immediately embed it into the wet Rollershield-VB. Recoat as necessary to ensure full embedment.
- F. Drying and Curing
1. Provide protection from rain and temperatures below 40°F (4°C) for a minimum of 24 hours after application. Longer protection may be necessary during lower temperatures and/or higher humidity conditions.
 2. Once cured, Rollershield may be exposed to the elements as long as six months once fully dry but should be covered as soon as practical.

3.06 JOB SITE CLEANUP

- A. Clean work area in accordance with contract documents removing all excess materials, droppings and debris. Clean adjacent surfaces.
- B. Other trades may now install their work – Sheet Metal (Section 07620), Sealants (Section 07900), Mechanical (Section 15000), Electrical (Section 16000).

3.07 PROTECTION

- A. Rollershield LAB System shall be protected from inclement weather and other sources of damage until dry and permanent protection in the form of flashings, sealants, cladding, etc. are installed.

Disclaimer

This Specification is published for general informational purposes only and is not intended to imply that these are the only materials, procedures, or methods, which are available or suitable. Materials, procedures, or methods may vary according to the particular circumstances, local building code requirements, design conditions, or statutory and regulatory requirements. While the information in this specification is believed to be accurate and reliable, it is presented without guarantee or responsibility on the part of Master Wall Inc.®



Rollershield LAB

Liquid Applied Air/Water Barrier

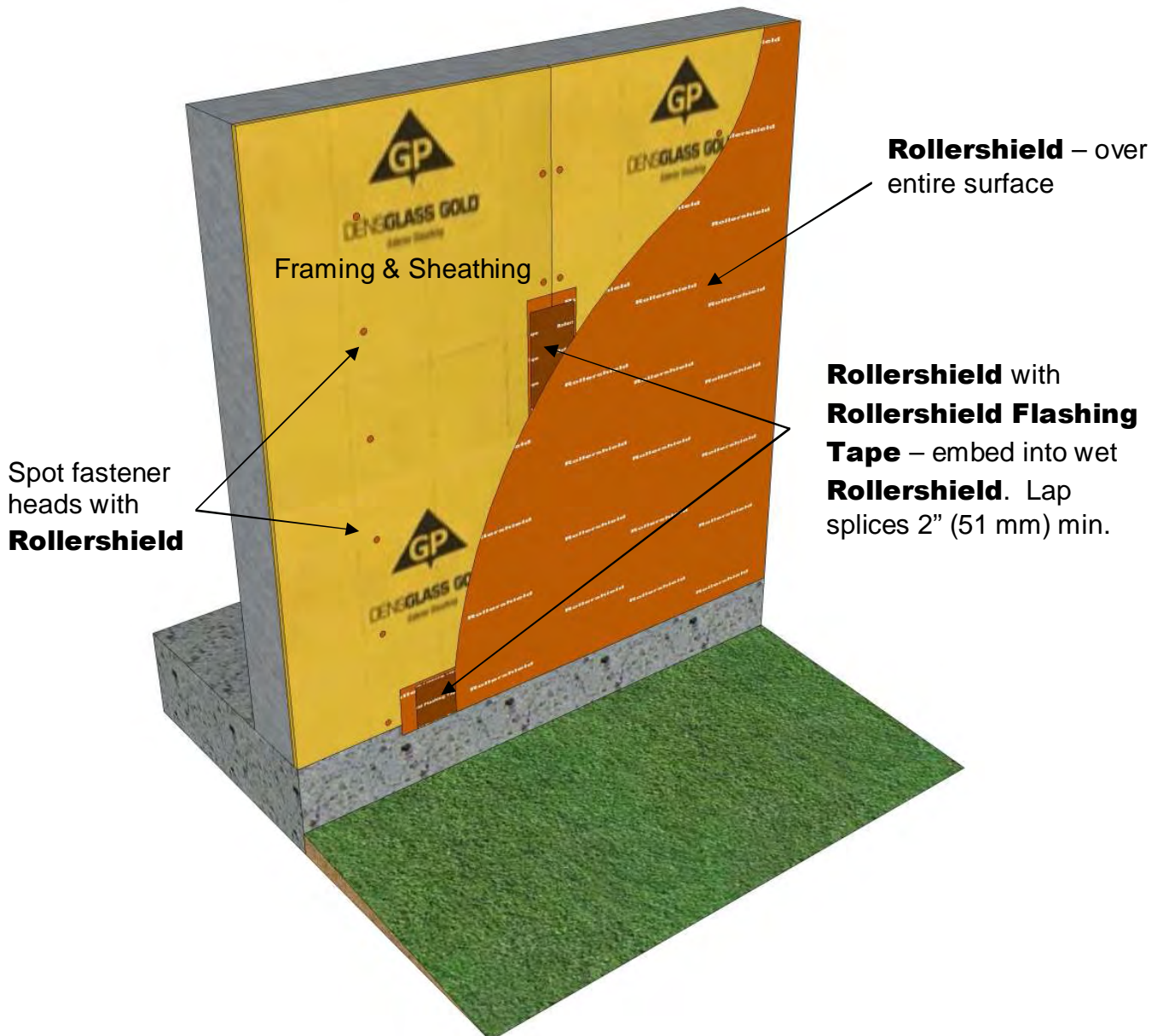

RSLAB-01 Application on Sheathing

These drawings relay the conceptual conditions of Master Wall® Systems and are not the construction drawings. Ultimately the design and detailing of an entire wall system is the responsibility of a professional. These details will guide the design professional in the use of Master Wall® Products. Master Wall disclaims design, warranty or construction intent or responsibility. **Bold or brand name = Master Wall® Product.** ©2014 Master Wall Inc.



Rollershield LAB

Liquid Applied Air/Water Barrier

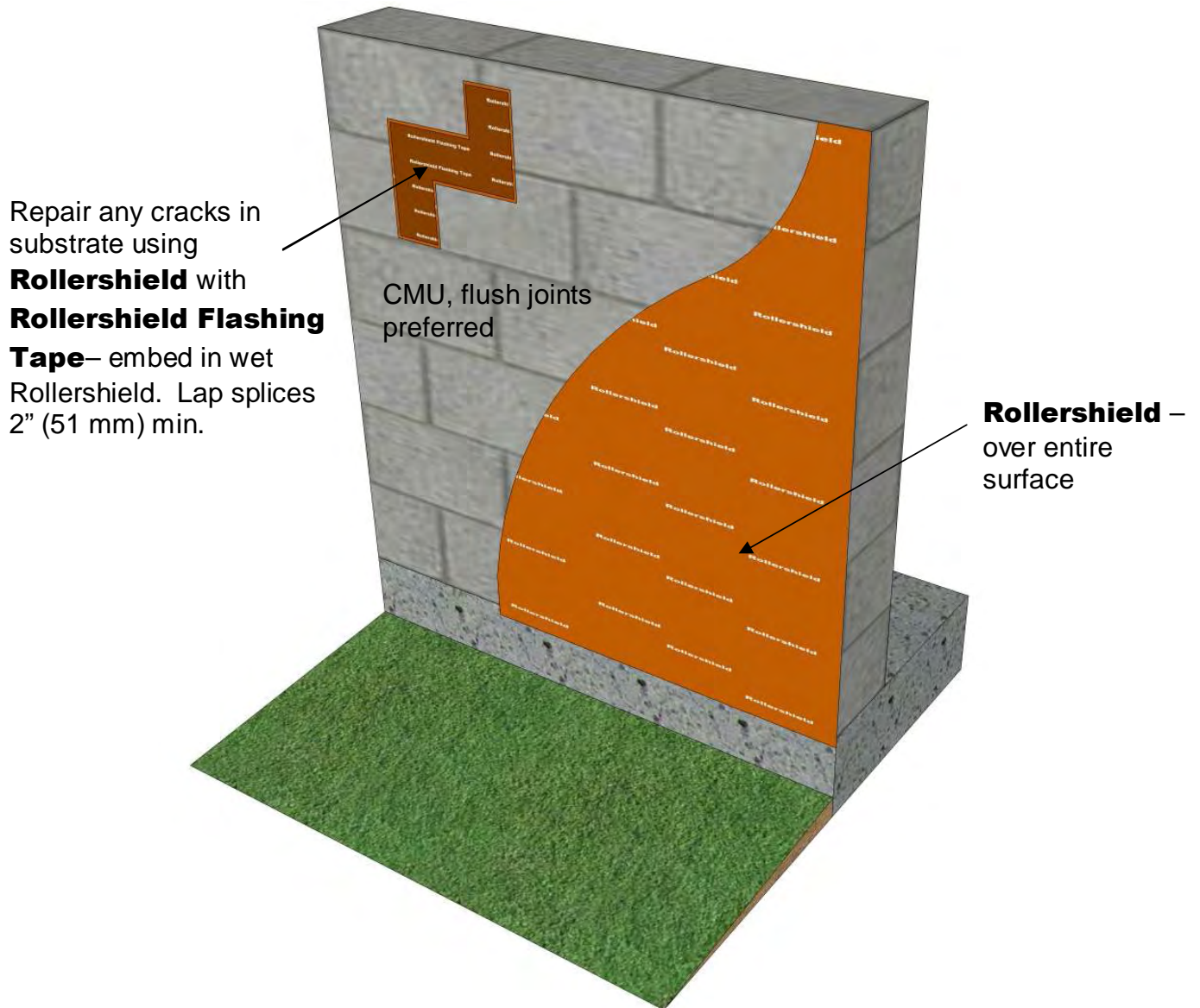

RSLAB-02 Application on CMU, Masonry or Concrete

These drawings relay the conceptual conditions of Master Wall® Systems and are not the construction drawings. Ultimately the design and detailing of an entire wall system is the responsibility of a professional. These details will guide the design professional in the use of Master Wall® Products. Master Wall disclaims design, warranty or construction intent or responsibility. **Bold or brand name = Master Wall® Product.** ©2014 Master Wall Inc.



Rollershield LAB

Liquid Applied Air/Water Barrier

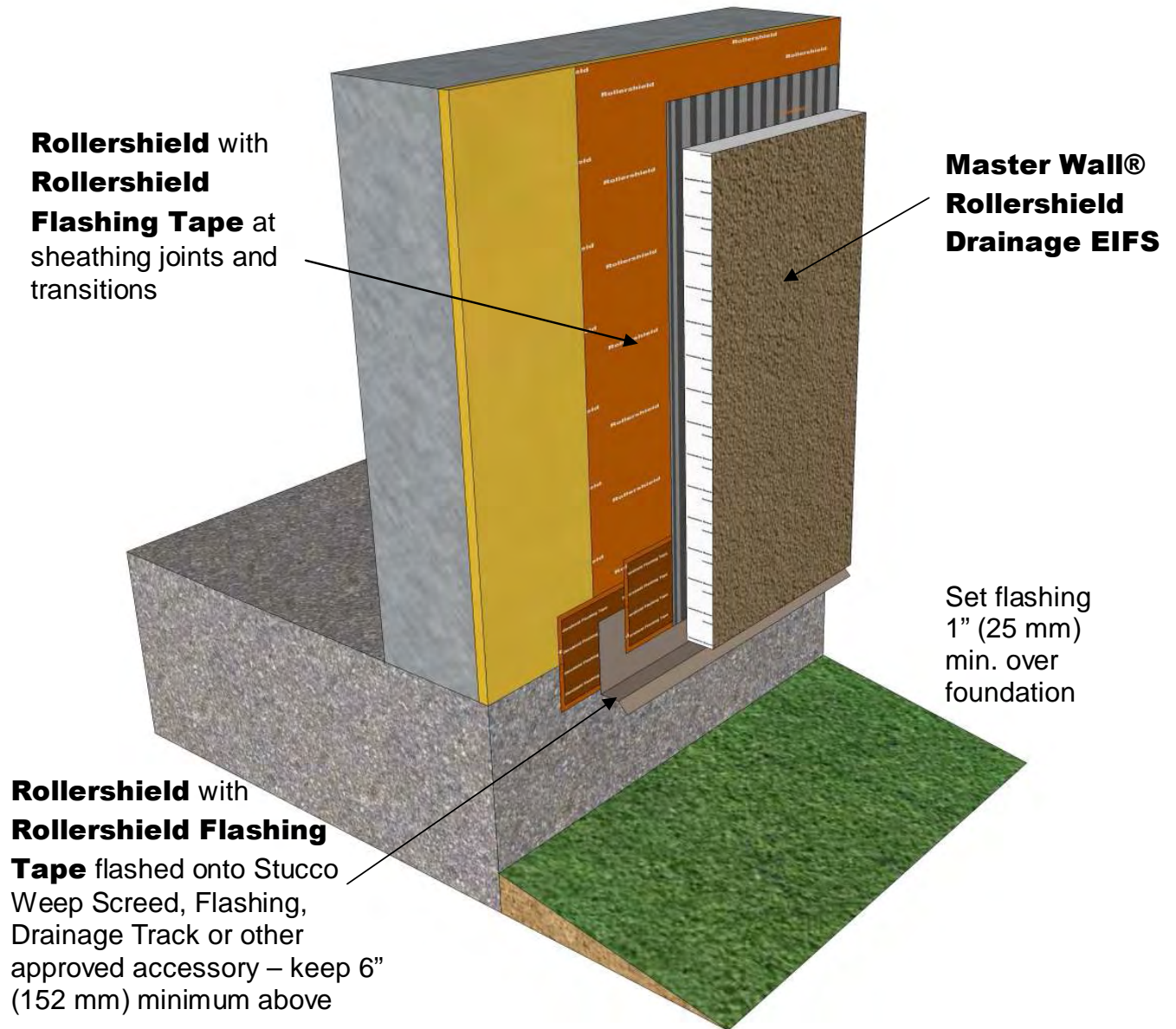

RSLAB-03 EIFS Termination

These drawings relay the conceptual conditions of Master Wall® Systems and are not the construction drawings. Ultimately the design and detailing of an entire wall system is the responsibility of a professional. These details will guide the design professional in the use of Master Wall® Products. Master Wall disclaims design, warranty or construction intent or responsibility. **Bold or brand name = Master Wall® Product.** ©2014 Master Wall Inc.



Rollershield LAB

Liquid Applied Air/Water Barrier

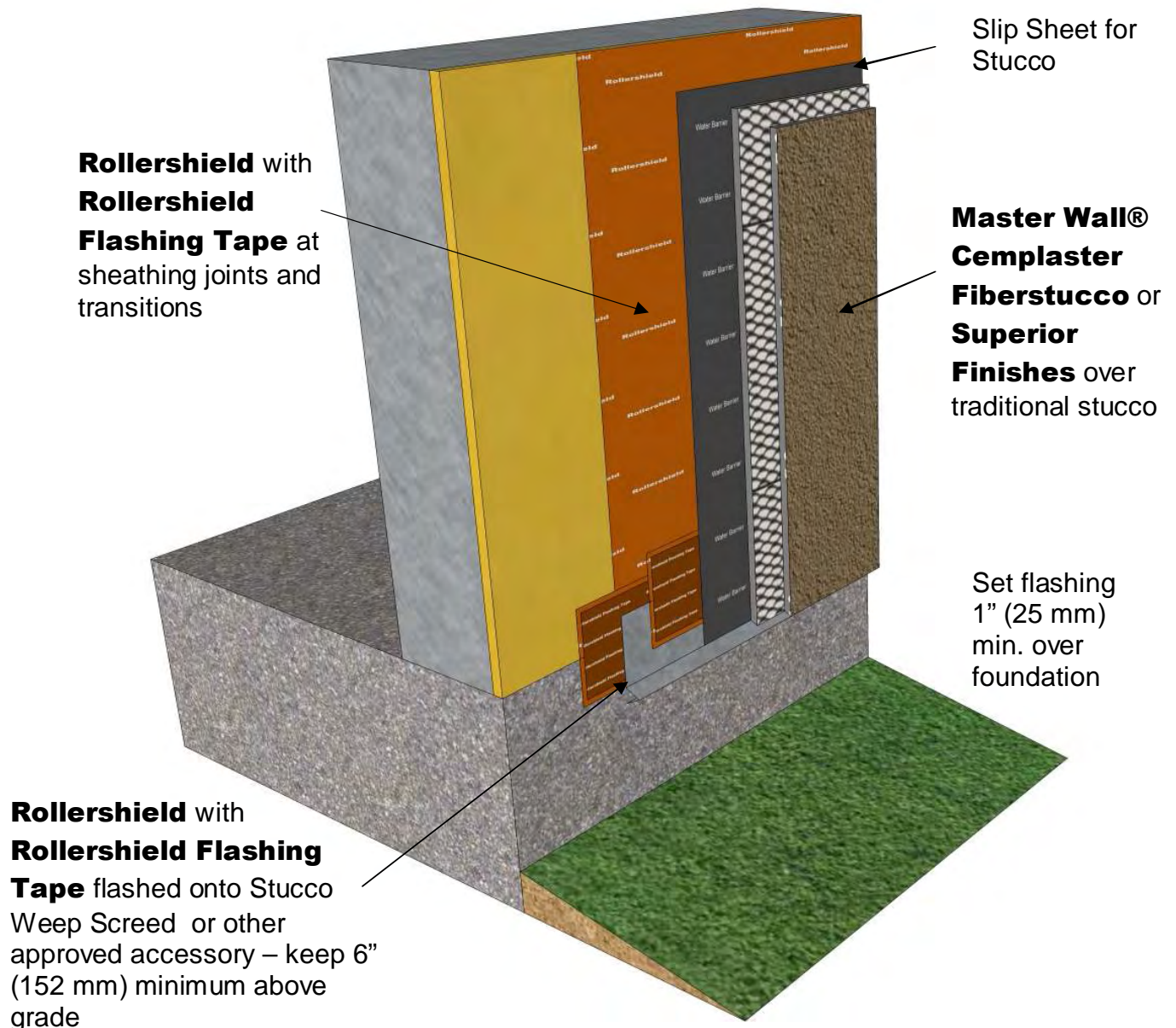

RSLAB-04 Stucco Termination at Foundation

These drawings relay the conceptual conditions of Master Wall® Systems and are not the construction drawings. Ultimately the design and detailing of an entire wall system is the responsibility of a professional. These details will guide the design professional in the use of Master Wall® Products. Master Wall disclaims design, warranty or construction intent or responsibility. **Bold or brand name = Master Wall® Product.** ©2014 Master Wall Inc.



Rollershield LAB

Liquid Applied Air/Water Barrier

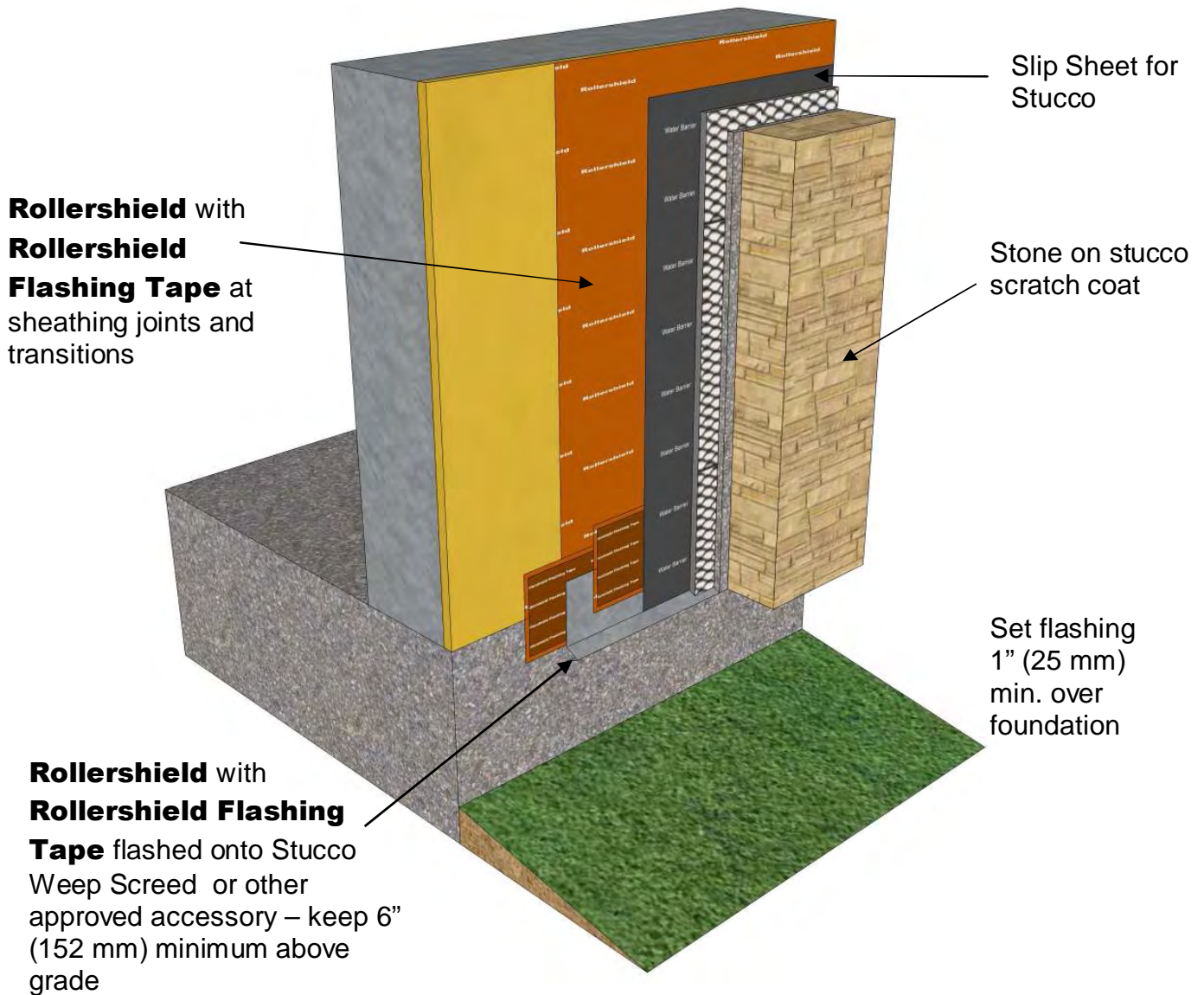

RSLAB-05 Stone Termination at Foundation

These drawings relay the conceptual conditions of Master Wall® Systems and are not the construction drawings. Ultimately the design and detailing of an entire wall system is the responsibility of a professional. These details will guide the design professional in the use of Master Wall® Products. Master Wall disclaims design, warranty or construction intent or responsibility. **Bold or brand name = Master Wall® Product.** ©2014 Master Wall Inc.



Rollershield LAB

Liquid Applied Air/Water Barrier

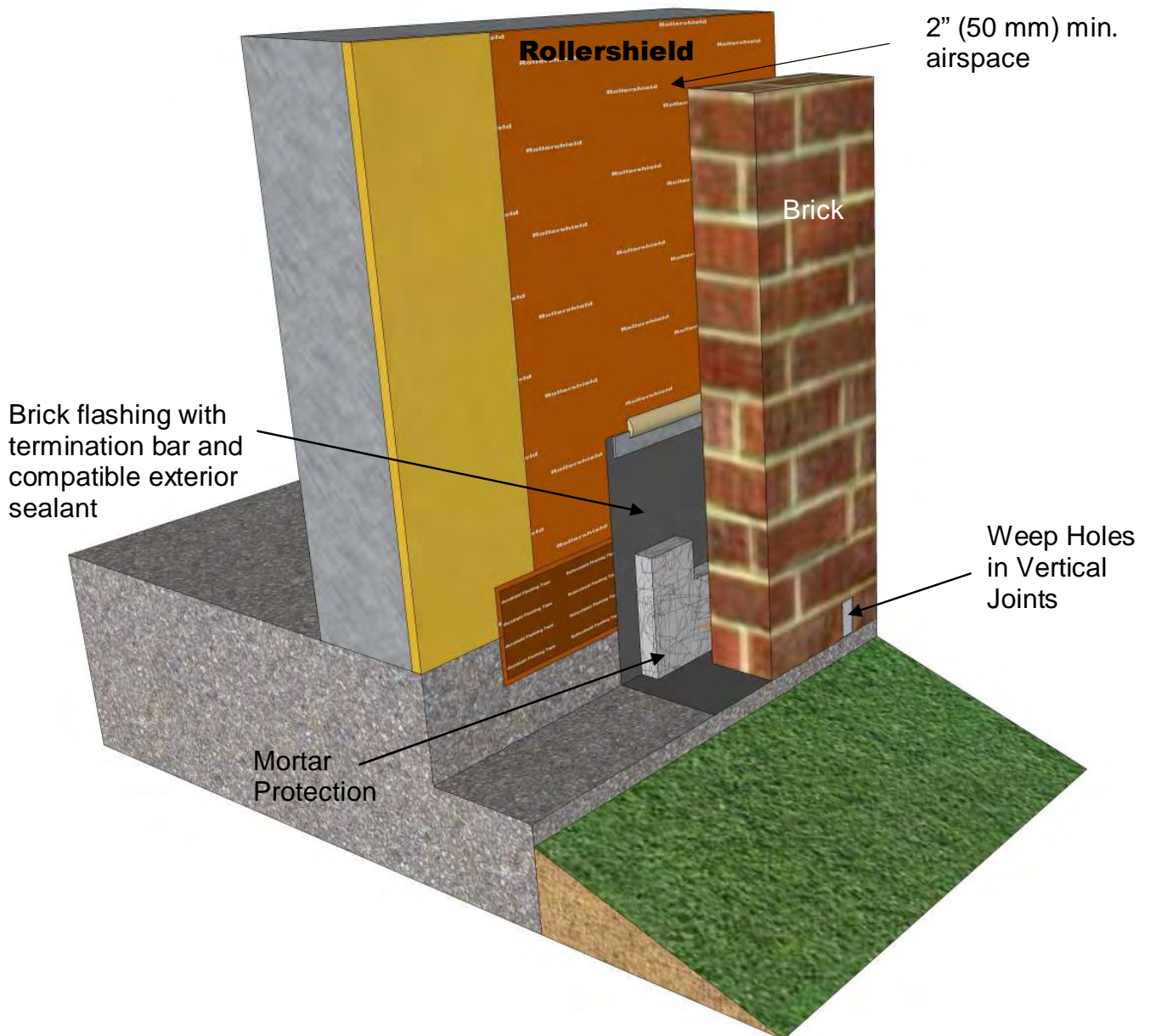

RSLAB-06 Brick Termination at Foundation

These drawings relay the conceptual conditions of Master Wall® Systems and are not the construction drawings. Ultimately the design and detailing of an entire wall system is the responsibility of a professional. These details will guide the design professional in the use of Master Wall® Products. Master Wall disclaims design, warranty or construction intent or responsibility. **Bold or brand name = Master Wall® Product.** ©2014 Master Wall Inc.



Rollershield LAB

Liquid Applied Air/Water Barrier

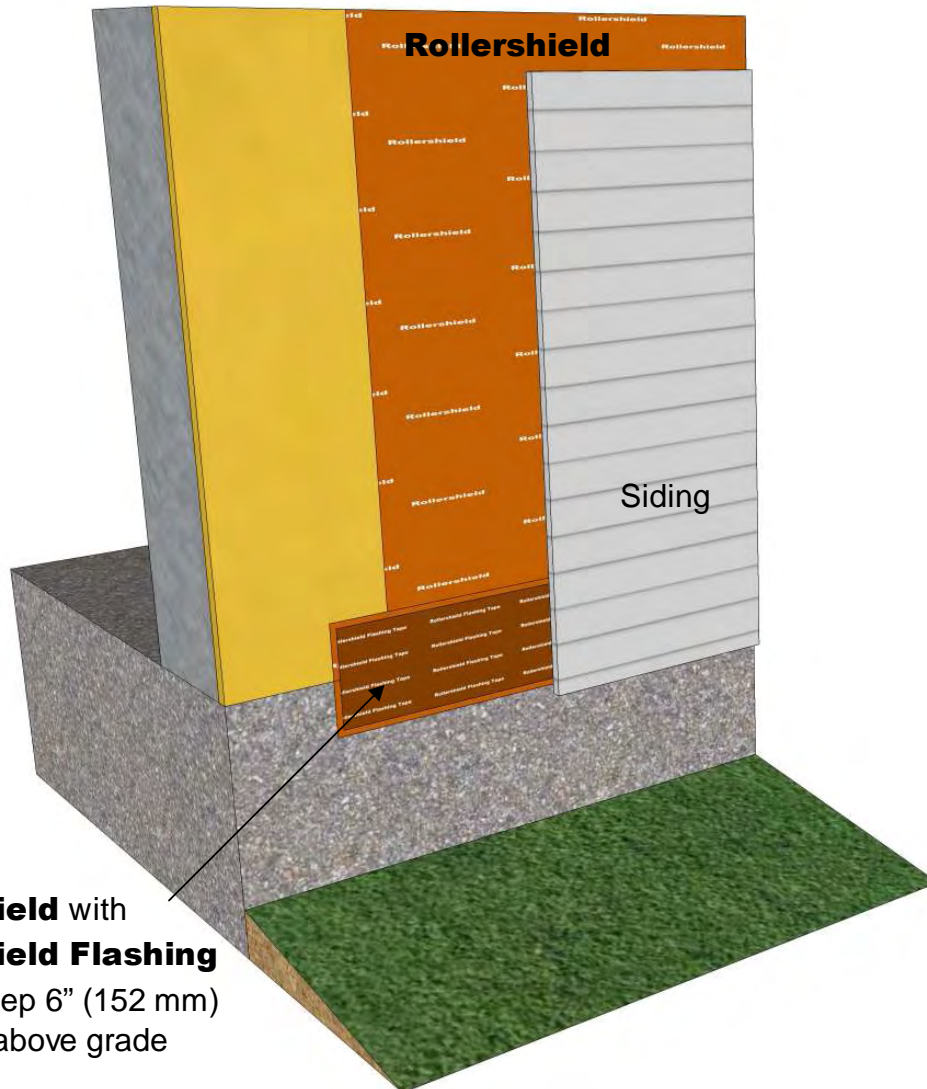

Rollershield with
Rollershield Flashing
Tape— keep 6" (152 mm)
minimum above grade

RSLAB-07 Siding Termination at Foundation

These drawings relay the conceptual conditions of Master Wall® Systems and are not the construction drawings. Ultimately the design and detailing of an entire wall system is the responsibility of a professional. These details will guide the design professional in the use of Master Wall® Products. Master Wall disclaims design, warranty or construction intent or responsibility. **Bold or brand name = Master Wall® Product.** ©2014 Master Wall Inc.



Rollershield LAB

Liquid Applied Air/Water Barrier

1. Start at the base of the window.
Apply wet **Rollershield** using a trowel, brush or roller to the sill and face of the wall.
2. Center and embed **Rollershield Flashing Tape** into the wet Rollershield and extend up the wall 3" (75 mm) up the jambs and onto the face of the wall. Smooth using trowel, brush or roller.
3. Apply jamb flashing in a similar manner extending the flashing 3" min. onto the sill surface.
4. Seal corner with an additional strip of **Rollershield Flashing Tape** centered in the corner
5. Apply head flashing in a similar manner.

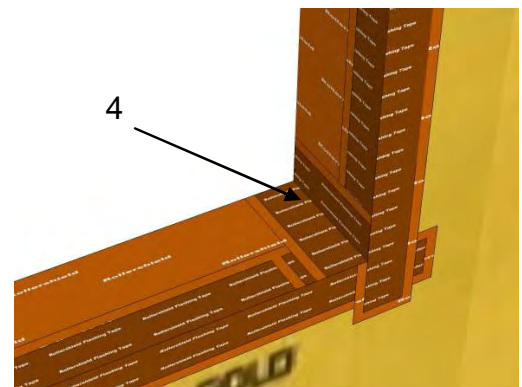
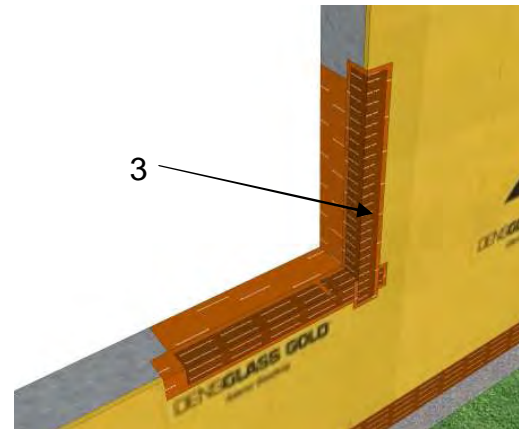
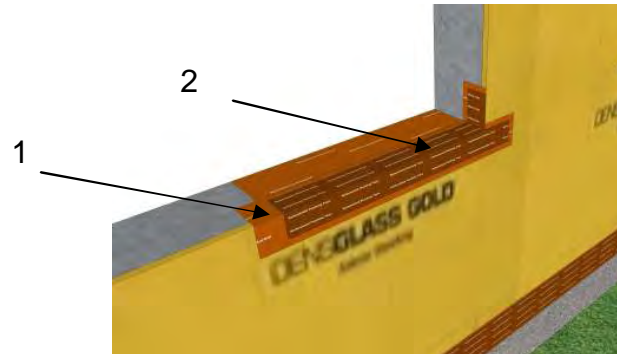

RSLAB-08 Basic Flashing – Method A

These drawings relay the conceptual conditions of Master Wall® Systems and are not the construction drawings. Ultimately the design and detailing of an entire wall system is the responsibility of a professional. These details will guide the design professional in the use of Master Wall® Products. Master Wall disclaims design, warranty or construction intent or responsibility. **Bold or brand name = Master Wall® Product.** ©2014 Master Wall Inc.



Rollershield LAB

Liquid Applied Air/Water Barrier

1. Start at the base of the window. Apply wet **Rollershield** using a trowel, brush or roller to the sill and face of the wall.
2. Center and embed **Rollershield Flashing Tape** into the wet **Rollershield**. Smooth using trowel, brush or roller.
3. Apply jamb flashing in a similar manner.
4. Apply head flashing in a similar manner.
5. Apply wet **Rollershield** at all corners and embed diagonal reinforcement.

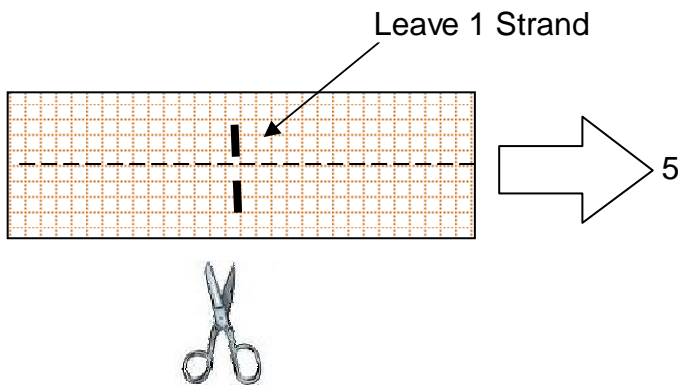
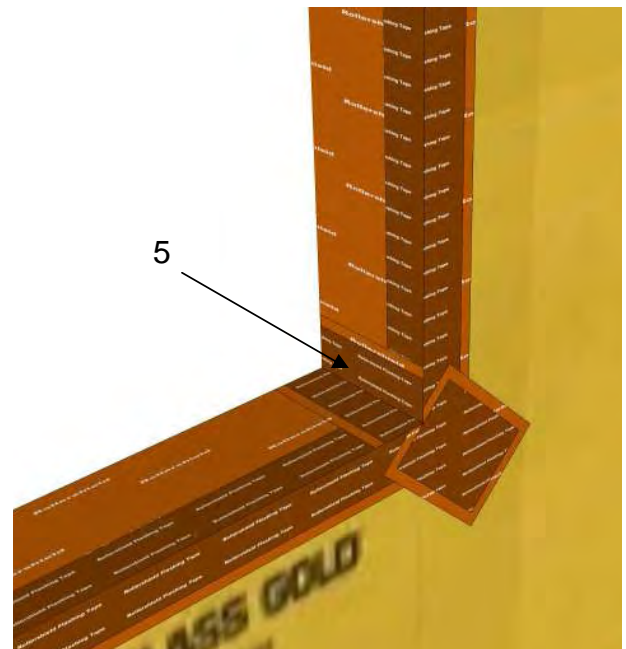
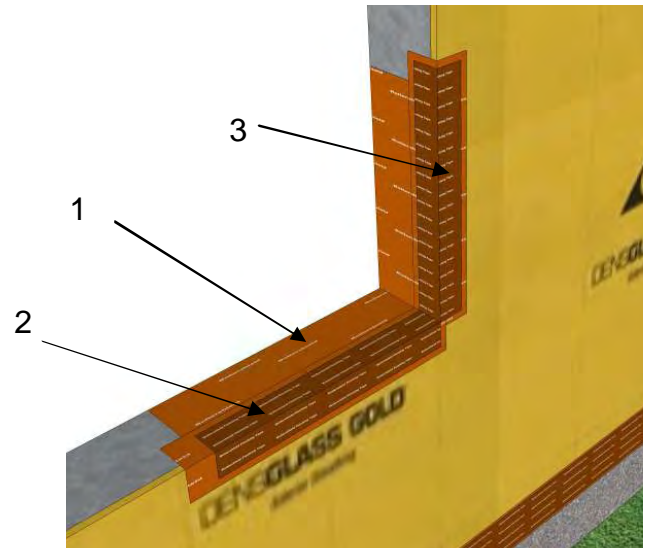

RSLAB-09 Basic Flashing – Method B

These drawings relay the conceptual conditions of Master Wall® Systems and are not the construction drawings. Ultimately the design and detailing of an entire wall system is the responsibility of a professional. These details will guide the design professional in the use of Master Wall® Products. Master Wall disclaims design, warranty or construction intent or responsibility. **Bold or brand name = Master Wall® Product.** ©2014 Master Wall Inc.



Rollershield LAB

Liquid Applied Air/Water Barrier

Rollershield with Rollershield Flashing Tape flashed onto window head flashing (shown) or onto self-flashing window flange

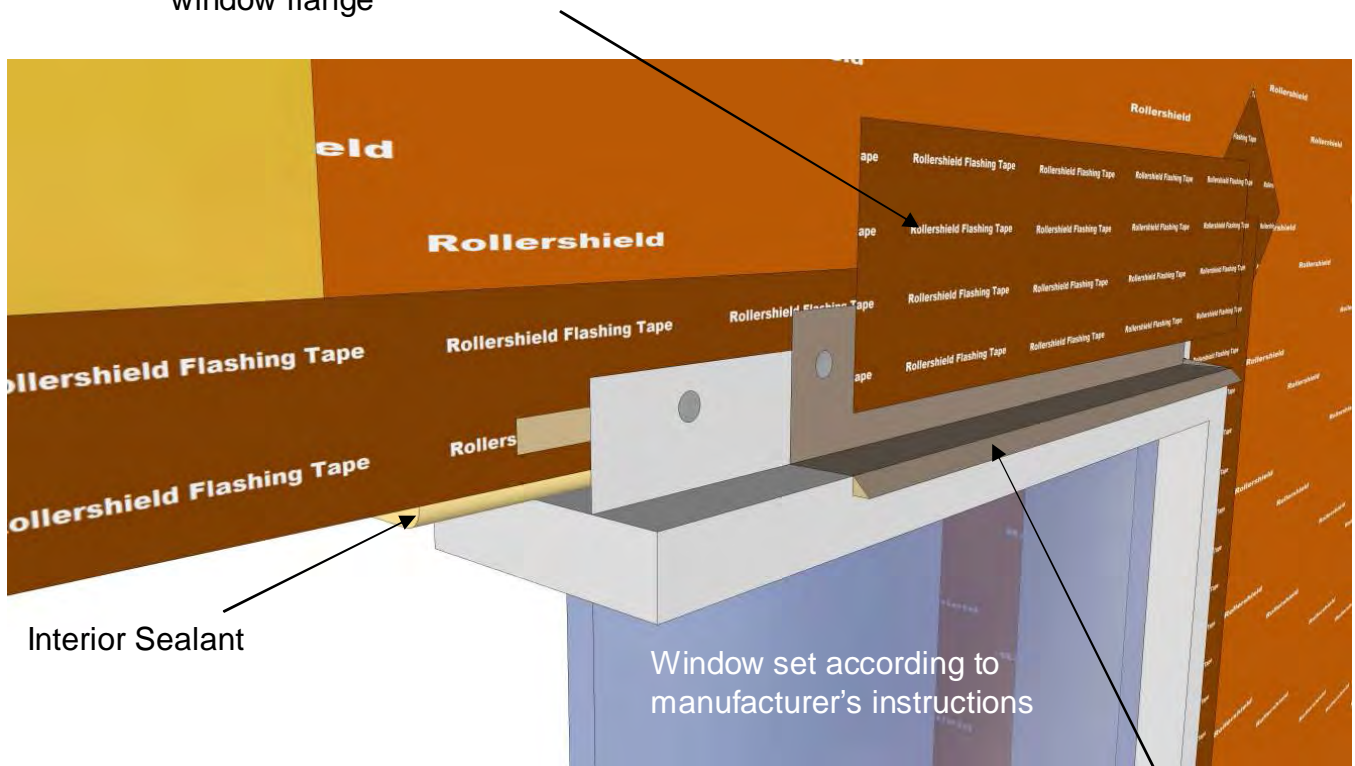

Head Flashing with end dams shown set in sealant

RSLAB-10 Window Head Detail

These drawings relay the conceptual conditions of Master Wall® Systems and are not the construction drawings. Ultimately the design and detailing of an entire wall system is the responsibility of a professional. These details will guide the design professional in the use of Master Wall® Products. Master Wall disclaims design, warranty or construction intent or responsibility. **Bold or brand name = Master Wall® Product.** ©2014 Master Wall Inc.



Rollershield LAB

Liquid Applied Air/Water Barrier

Rollershield with Rollershield
Flashing Tape flashed onto self-flashing
window flange

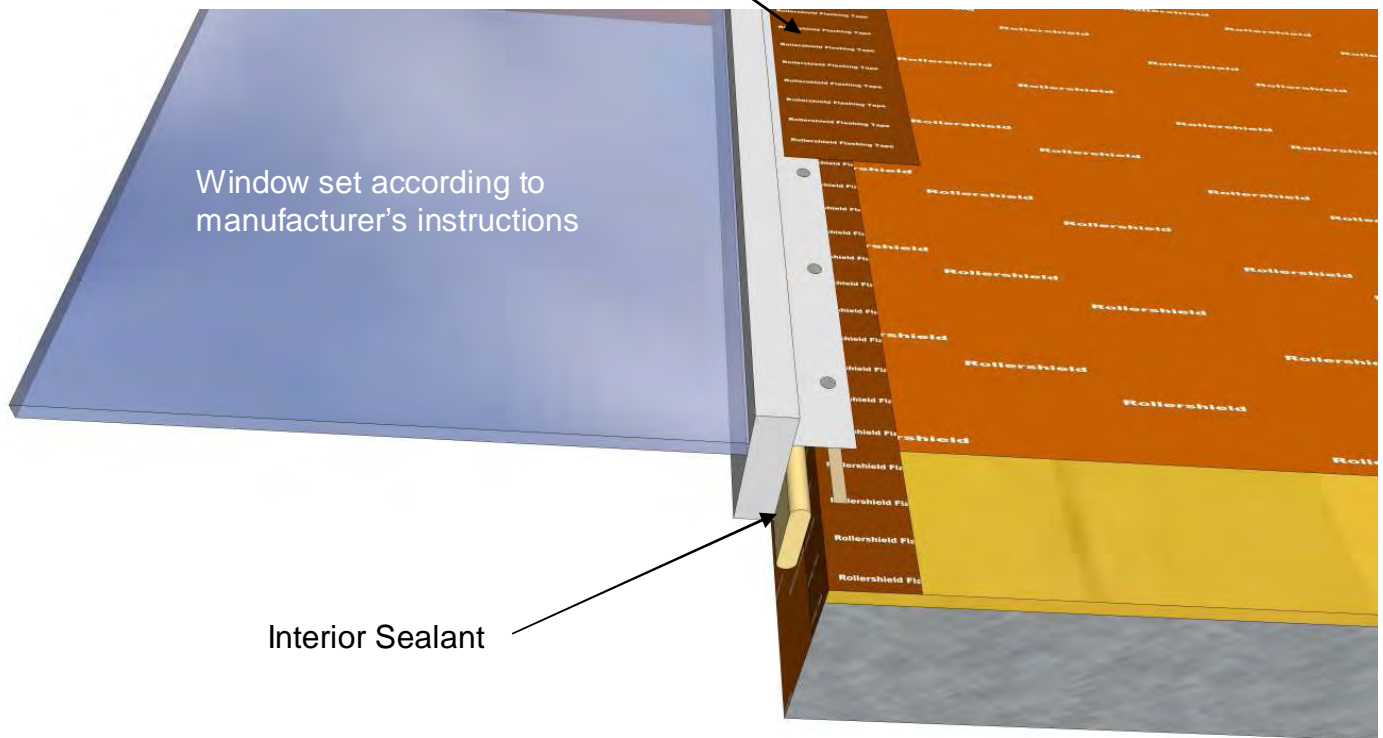

RSLAB-11 Typical Window Jamb Detail

These drawings relay the conceptual conditions of Master Wall® Systems and are not the construction drawings. Ultimately the design and detailing of an entire wall system is the responsibility of a professional. These details will guide the design professional in the use of Master Wall® Products. Master Wall disclaims design, warranty or construction intent or responsibility. **Bold or brand name = Master Wall® Product.** ©2014 Master Wall Inc.



Rollershield LAB

Liquid Applied Air/Water Barrier

Rollershield with Rollershield Flashing Tape flashed onto self-flashing window flange

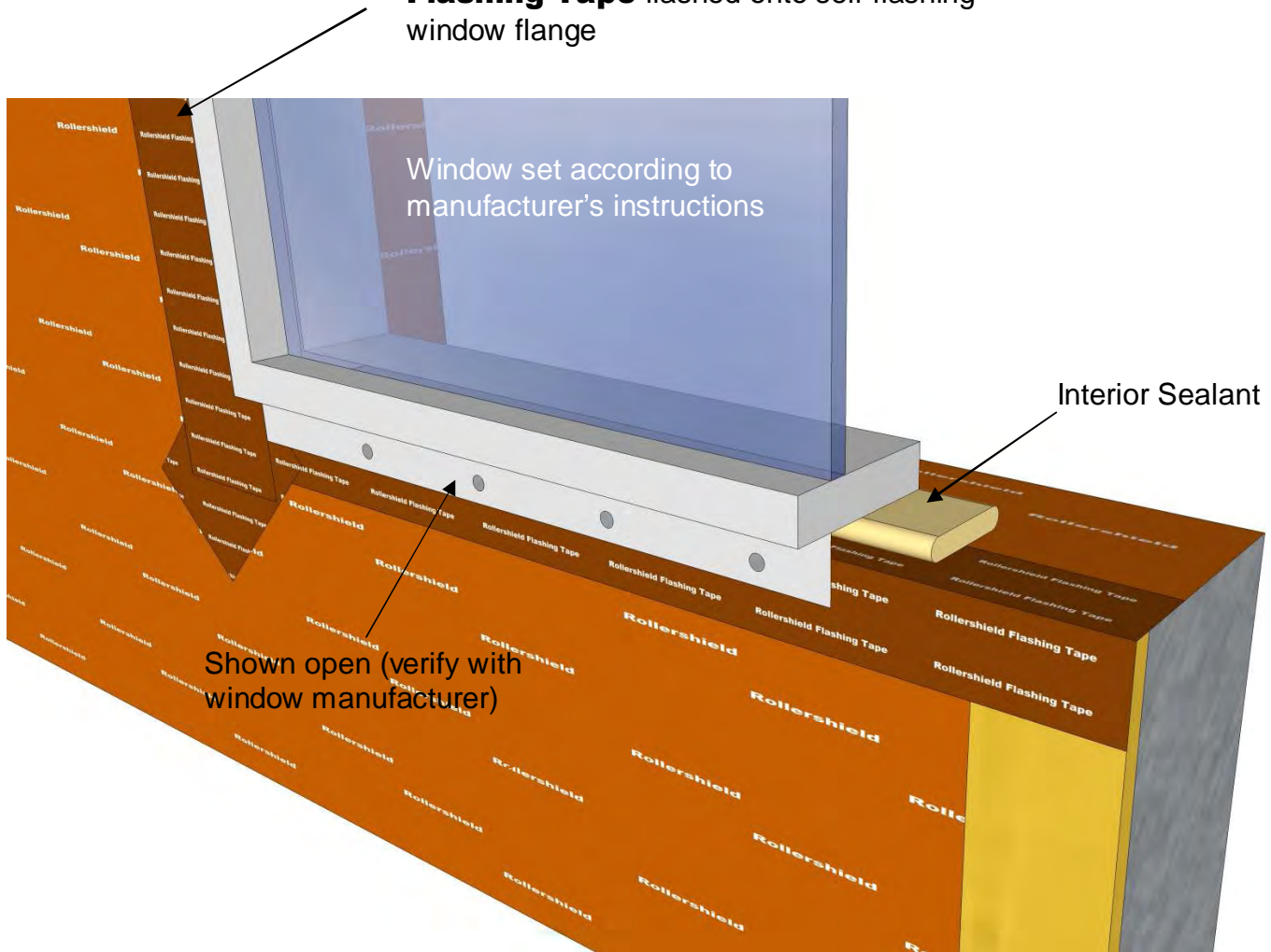

RSLAB-12 Typical Window Sill Detail

These drawings relay the conceptual conditions of Master Wall® Systems and are not the construction drawings. Ultimately the design and detailing of an entire wall system is the responsibility of a professional. These details will guide the design professional in the use of Master Wall® Products. Master Wall disclaims design, warranty or construction intent or responsibility. **Bold or brand name = Master Wall® Product.** ©2014 Master Wall Inc.



Rollershield LAB

Liquid Applied Air/Water Barrier

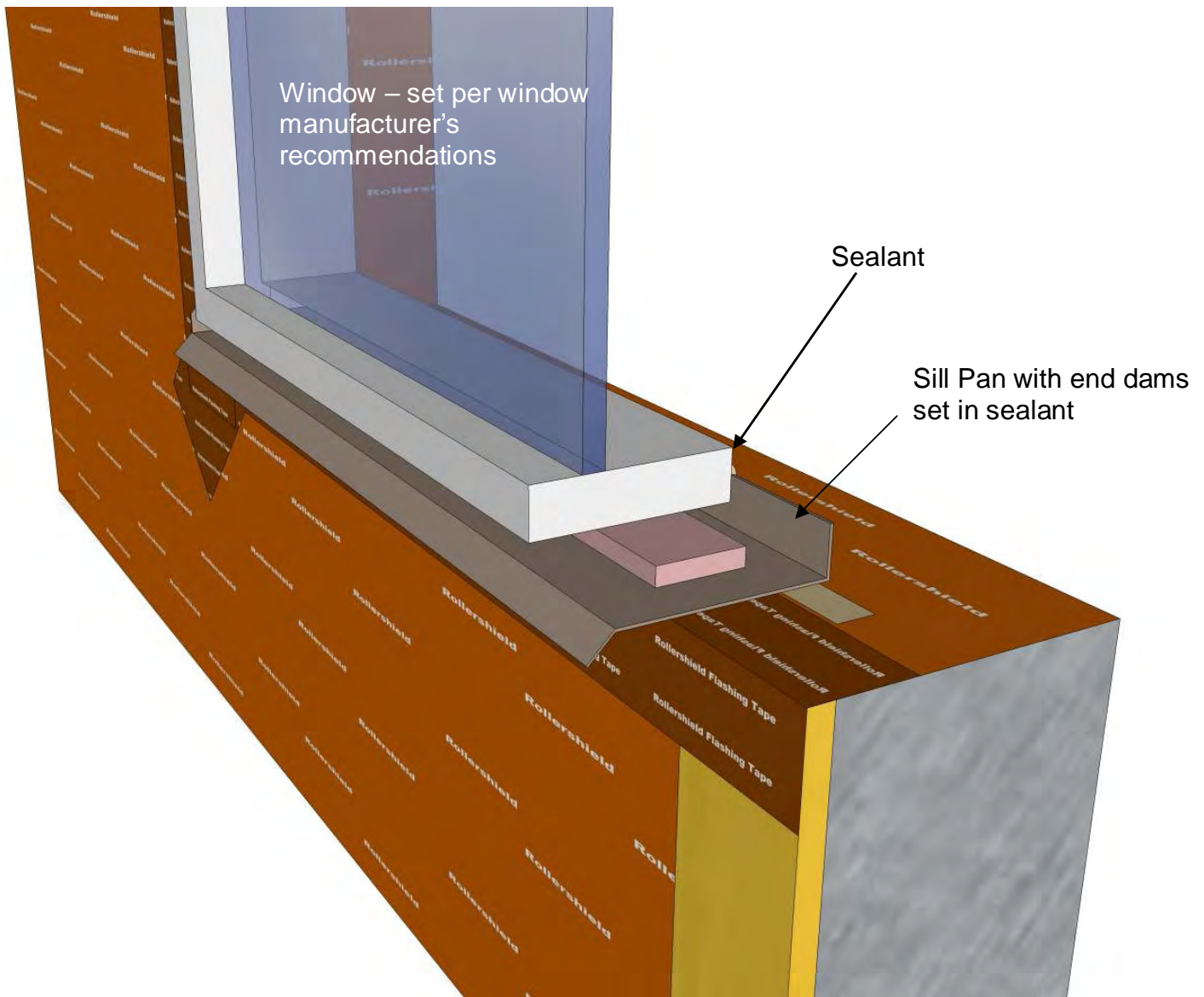

RSLAB-13 Typical Window Sill Detail (Pan)

These drawings relay the conceptual conditions of Master Wall® Systems and are not the construction drawings. Ultimately the design and detailing of an entire wall system is the responsibility of a professional. These details will guide the design professional in the use of Master Wall® Products. Master Wall disclaims design, warranty or construction intent or responsibility. **Bold or brand name = Master Wall® Product.** ©2014 Master Wall Inc.



Rollershield LAB

Liquid Applied Air/Water Barrier

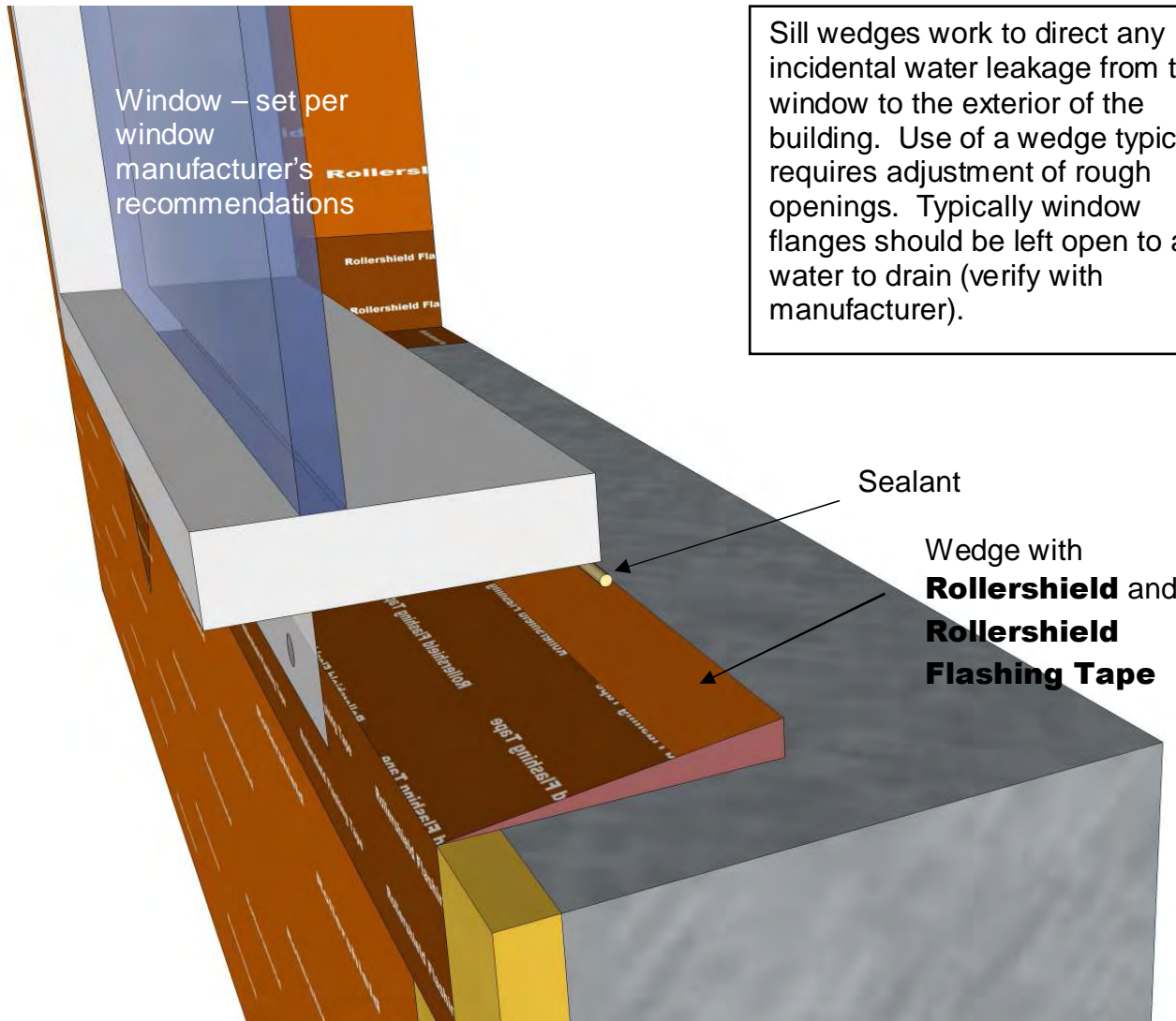

Sill wedges work to direct any incidental water leakage from the window to the exterior of the building. Use of a wedge typically requires adjustment of rough openings. Typically window flanges should be left open to allow water to drain (verify with manufacturer).

RSLAB-14 Typical Window Sill Detail (Wedge)

These drawings relay the conceptual conditions of Master Wall® Systems and are not the construction drawings. Ultimately the design and detailing of an entire wall system is the responsibility of a professional. These details will guide the design professional in the use of Master Wall® Products. Master Wall disclaims design, warranty or construction intent or responsibility. **Bold or brand name = Master Wall® Product.** ©2014 Master Wall Inc.



Rollershield LAB

Liquid Applied Air/Water Barrier

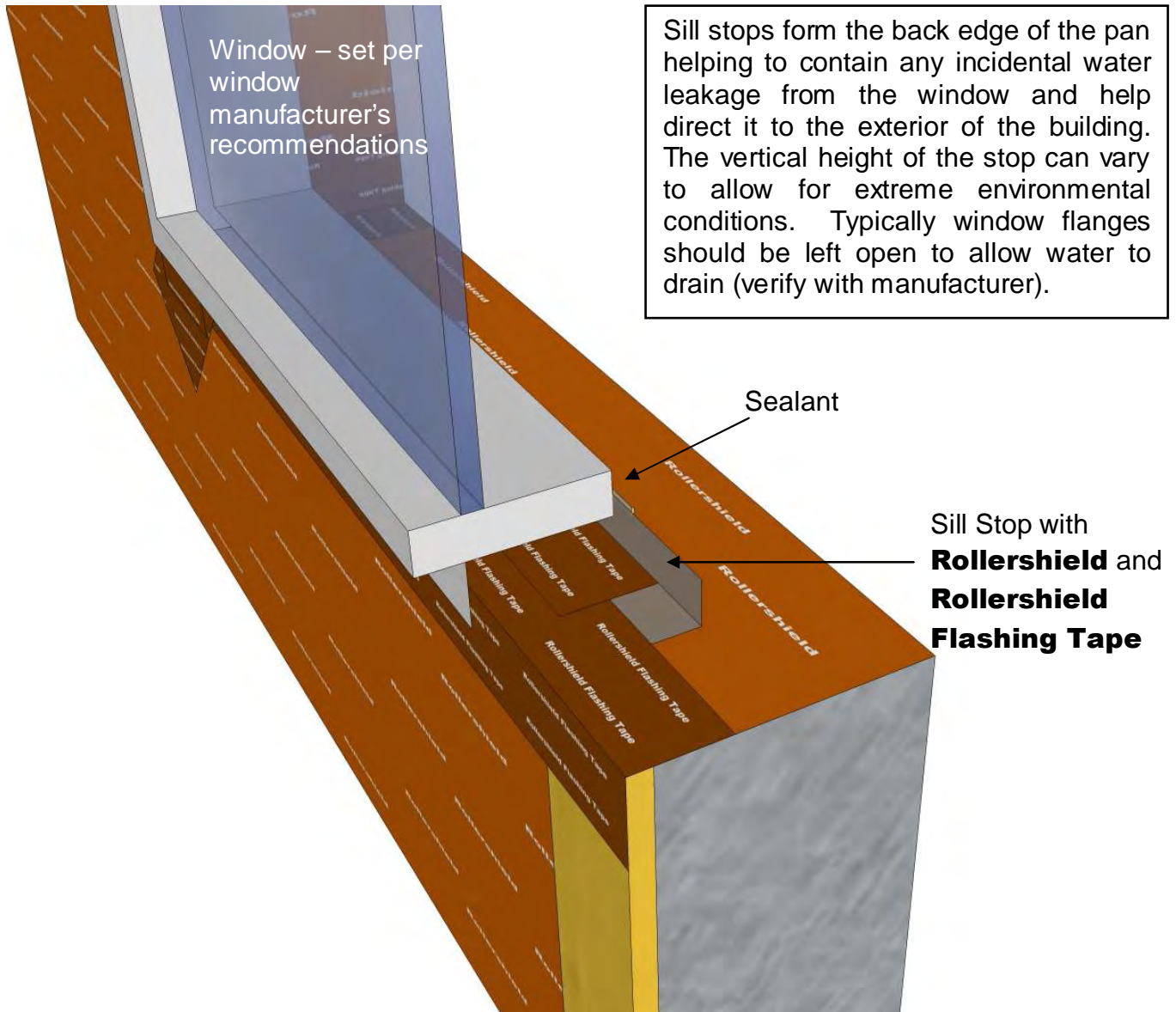

Sill stops form the back edge of the pan helping to contain any incidental water leakage from the window and help direct it to the exterior of the building. The vertical height of the stop can vary to allow for extreme environmental conditions. Typically window flanges should be left open to allow water to drain (verify with manufacturer).

RSLAB-15 Typical Window Sill Detail (Stop)

These drawings relay the conceptual conditions of Master Wall® Systems and are not the construction drawings. Ultimately the design and detailing of an entire wall system is the responsibility of a professional. These details will guide the design professional in the use of Master Wall® Products. Master Wall disclaims design, warranty or construction intent or responsibility. **Bold or brand name = Master Wall® Product.** ©2014 Master Wall Inc.



Rollershield LAB

Liquid Applied Air/Water Barrier

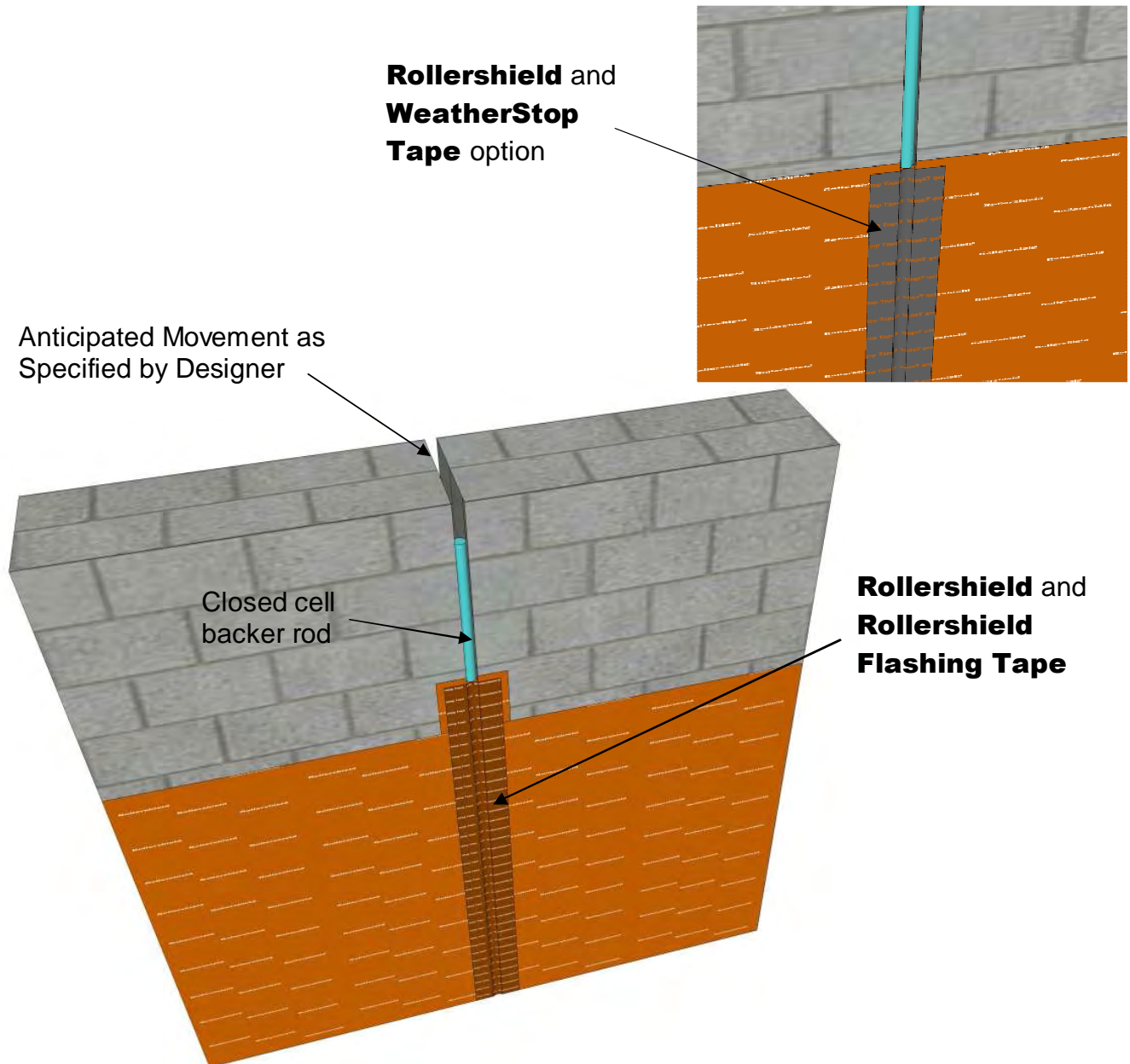

RSLAB-16 Typical Building Expansion Joint

These drawings relay the conceptual conditions of Master Wall® Systems and are not the construction drawings. Ultimately the design and detailing of an entire wall system is the responsibility of a professional. These details will guide the design professional in the use of Master Wall® Products. Master Wall disclaims design, warranty or construction intent or responsibility. **Bold or brand name = Master Wall® Product.** ©2014 Master Wall Inc.



Rollershield LAB

Liquid Applied Air/Water Barrier

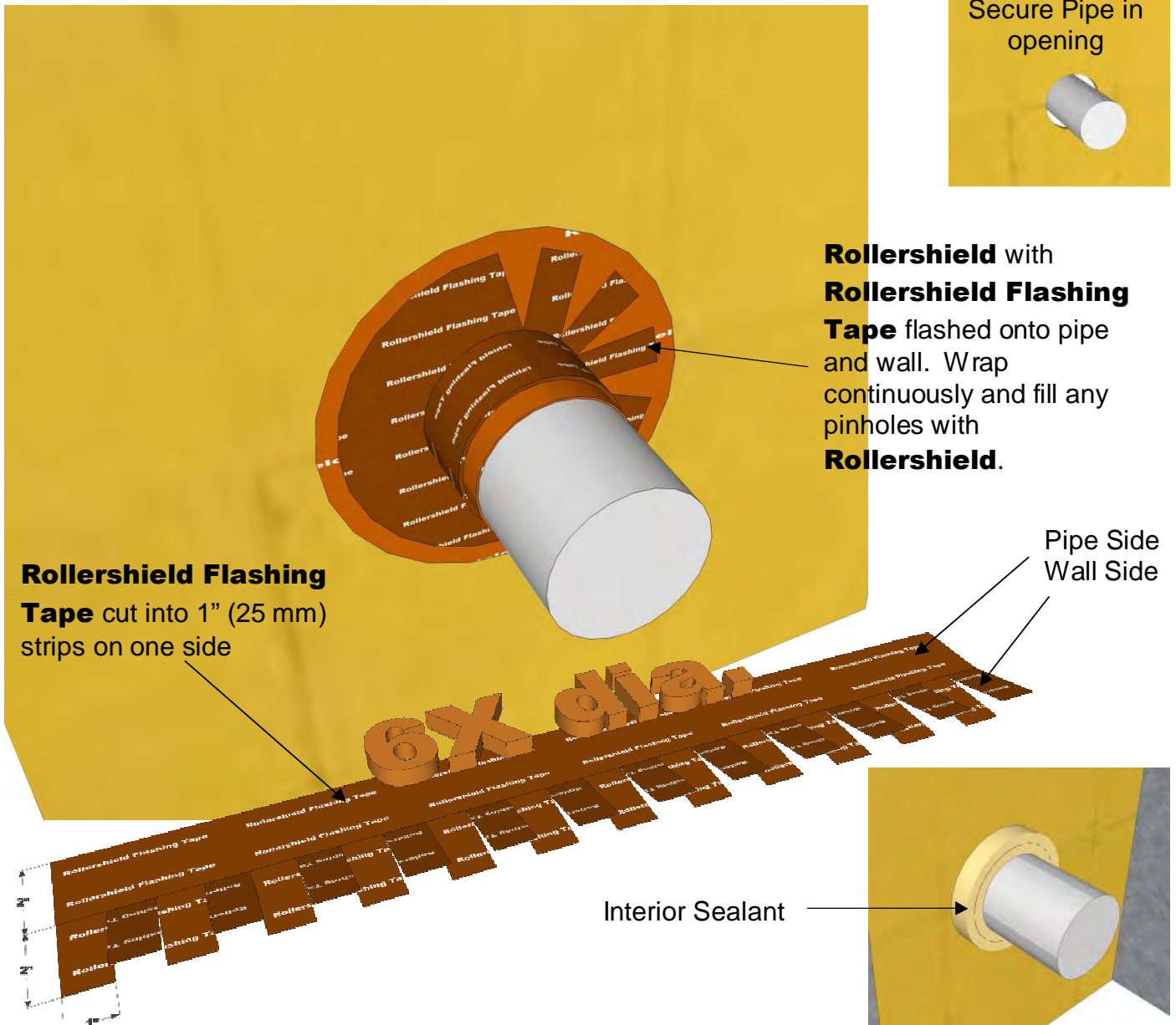

RSLAB-17 Typical Pipe Detail

These drawings relay the conceptual conditions of Master Wall® Systems and are not the construction drawings. Ultimately the design and detailing of an entire wall system is the responsibility of a professional. These details will guide the design professional in the use of Master Wall® Products. Master Wall disclaims design, warranty or construction intent or responsibility. **Bold or brand name = Master Wall® Product.** ©2014 Master Wall Inc.



Rollershield LAB

Liquid Applied Air/Water Barrier

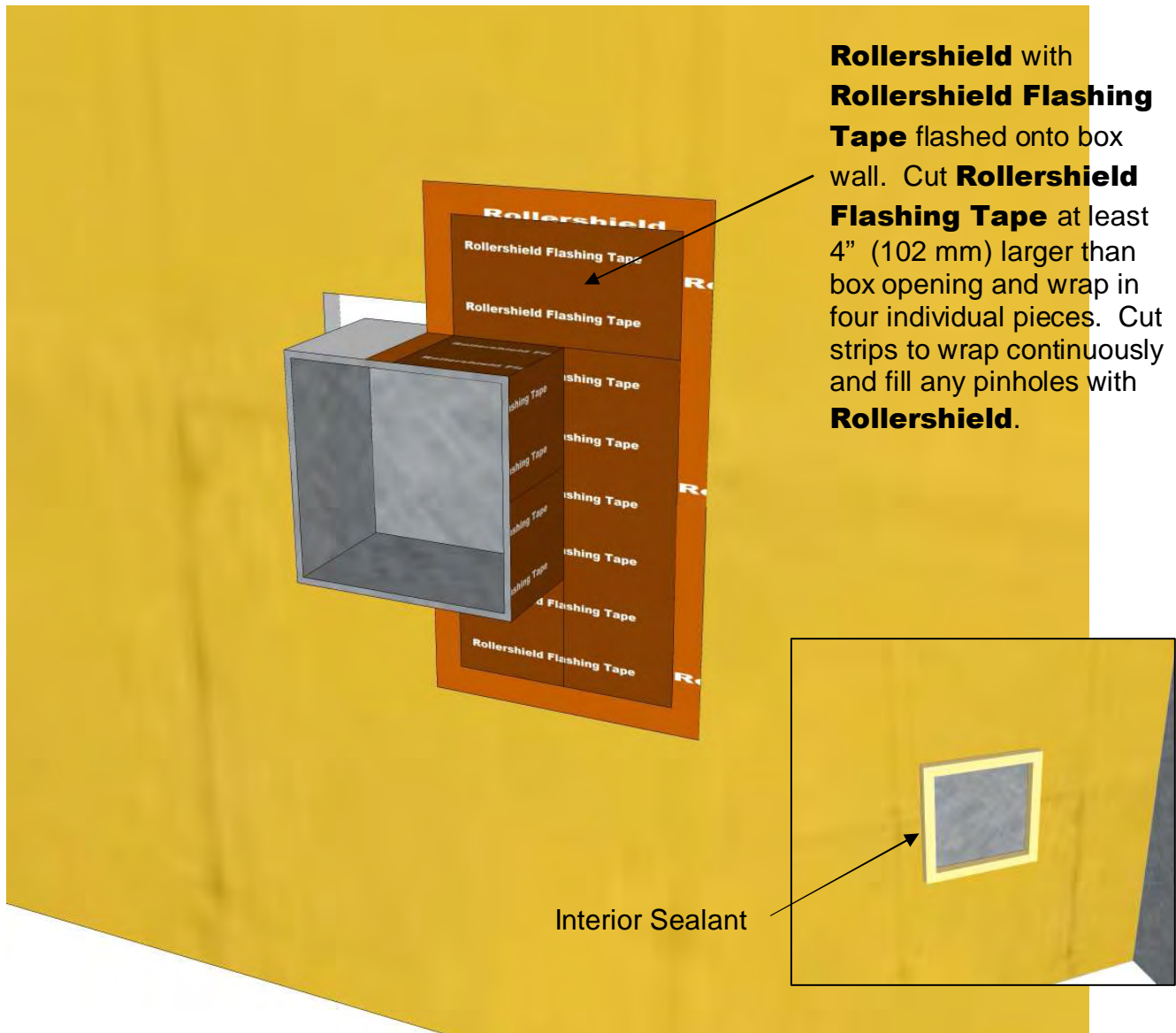

RSLAB-18 Box Detail

These drawings relay the conceptual conditions of Master Wall® Systems and are not the construction drawings. Ultimately the design and detailing of an entire wall system is the responsibility of a professional. These details will guide the design professional in the use of Master Wall® Products. Master Wall disclaims design, warranty or construction intent or responsibility. **Bold or brand name = Master Wall® Product.** ©2014 Master Wall Inc.



Rollershield LAB

Liquid Applied Air/Water Barrier

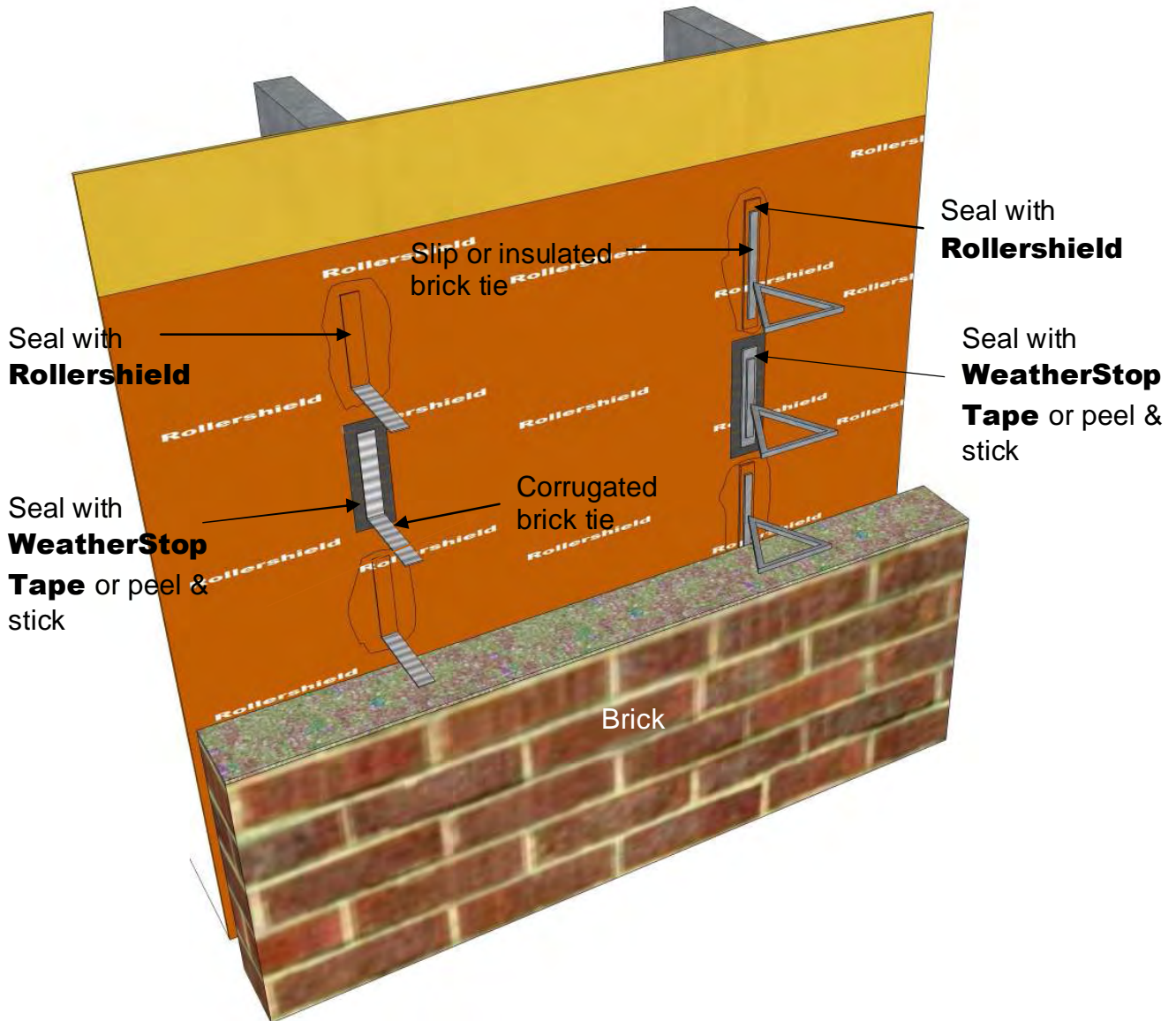

RSLAB-19 Brick Tie Detail

These drawings relay the conceptual conditions of Master Wall® Systems and are not the construction drawings. Ultimately the design and detailing of an entire wall system is the responsibility of a professional. These details will guide the design professional in the use of Master Wall® Products. Master Wall disclaims design, warranty or construction intent or responsibility. **Bold or brand name = Master Wall® Product.** ©2014 Master Wall Inc.



Rollershield LAB

Liquid Applied Air/Water Barrier

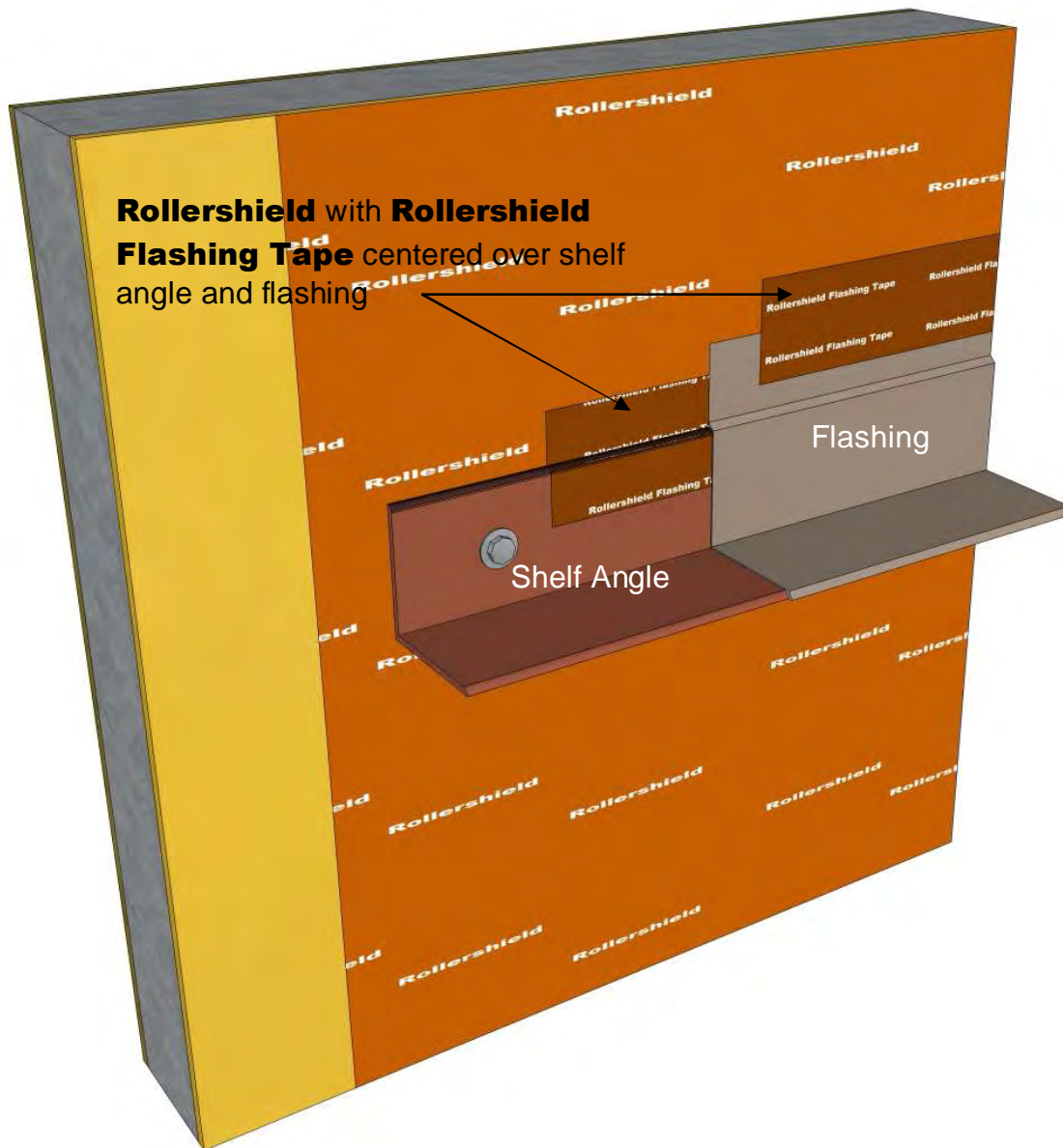

RSLAB-20 Structural Angle Detail

These drawings relay the conceptual conditions of Master Wall® Systems and are not the construction drawings. Ultimately the design and detailing of an entire wall system is the responsibility of a professional. These details will guide the design professional in the use of Master Wall® Products. Master Wall disclaims design, warranty or construction intent or responsibility. **Bold or brand name = Master Wall® Product.** ©2014 Master Wall Inc.



Rollershield LAB

Liquid Applied Air/Water Barrier

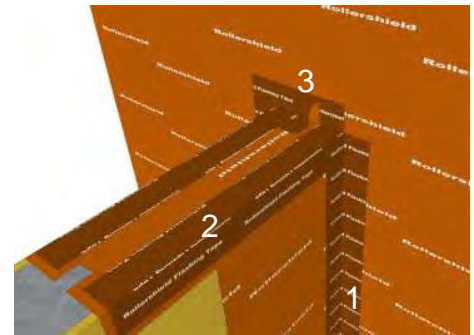
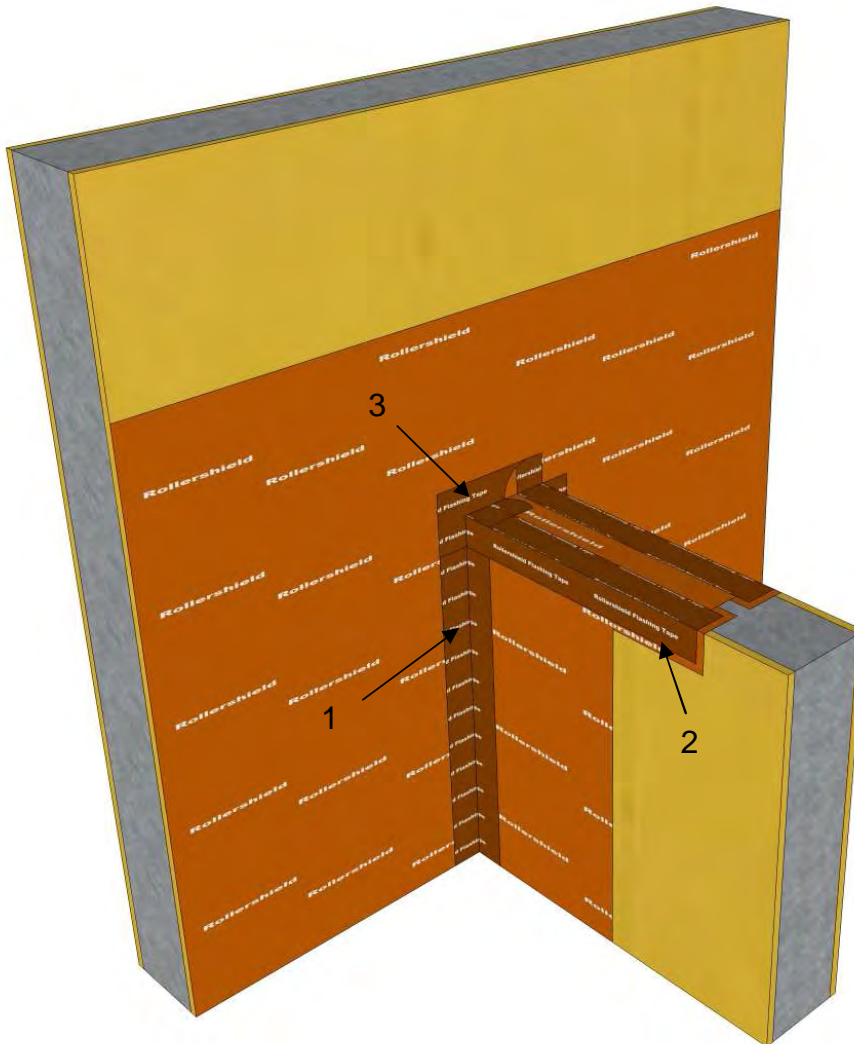

1. Start at the vertical wall section. Apply wet **Rollershield** using a trowel, brush or roller to the sill and face of the wall and center and embed **Rollershield Flashing Tape** cut 2" (50 mm) longer than the height of the wall into the wet **Rollershield**. Smooth using trowel, brush or roller.

2. Apply horizontal flashing in a similar manner extending the same 2" (50 mm) onto the vertical wall.

3. Center a cross-piece of **Rollershield Flashing Tape** at the horizontal/vertical transition.

RSLAB-21 Saddle Wall Detail

These drawings relay the conceptual conditions of Master Wall® Systems and are not the construction drawings. Ultimately the design and detailing of an entire wall system is the responsibility of a professional. These details will guide the design professional in the use of Master Wall® Products. Master Wall disclaims design, warranty or construction intent or responsibility. **Bold or brand name = Master Wall® Product.** ©2014 Master Wall Inc.



Rollershield LAB

Liquid Applied Air/Water Barrier

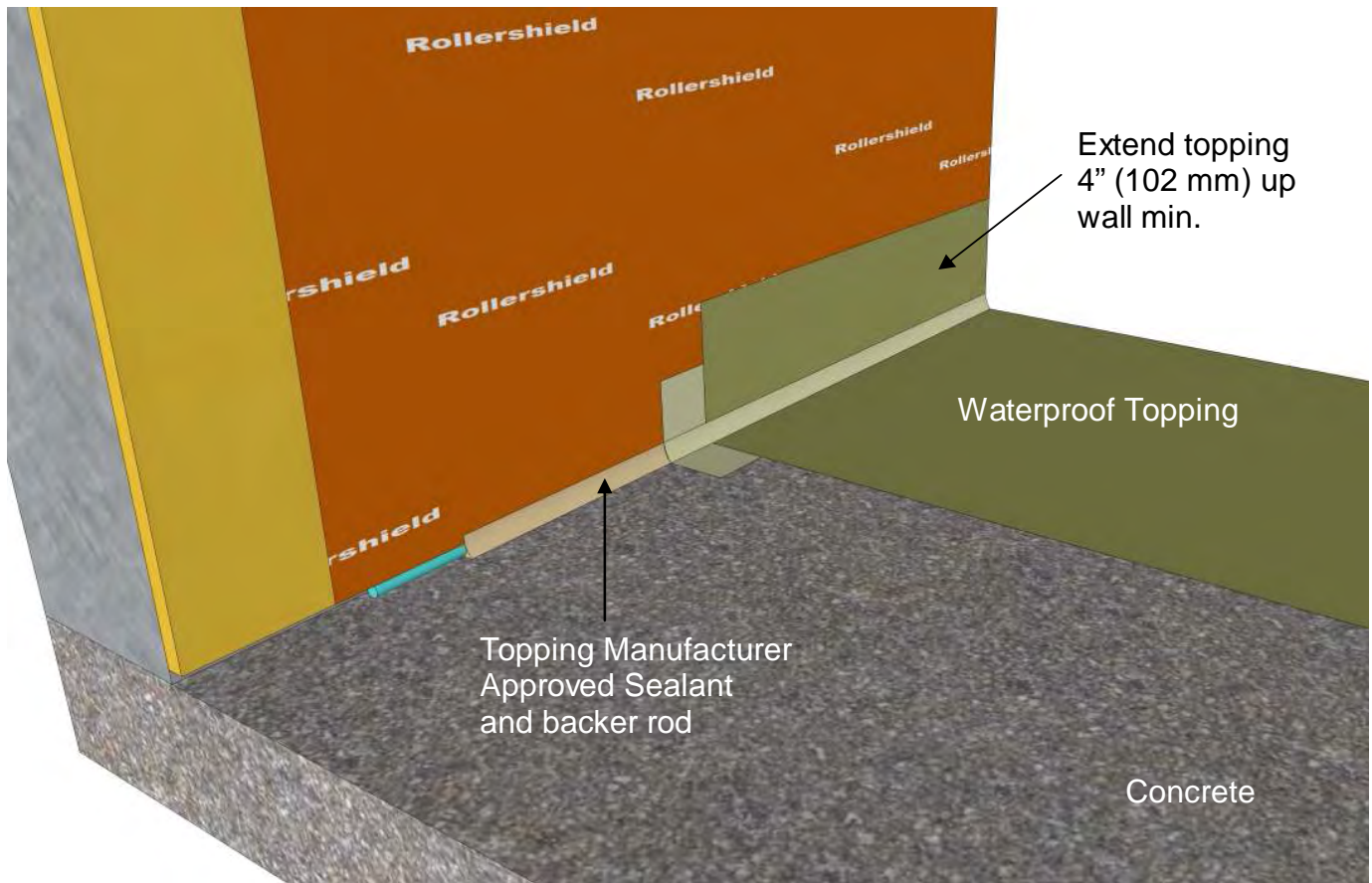

Note: Topping must be compatible with acrylic water barriers

RSLAB-22 Deck Termination Detail

These drawings relay the conceptual conditions of Master Wall® Systems and are not the construction drawings. Ultimately the design and detailing of an entire wall system is the responsibility of a professional. These details will guide the design professional in the use of Master Wall® Products. Master Wall disclaims design, warranty or construction intent or responsibility. **Bold or brand name = Master Wall® Product.** ©2014 Master Wall Inc.



Rollershield LAB

Liquid Applied Air/Water Barrier

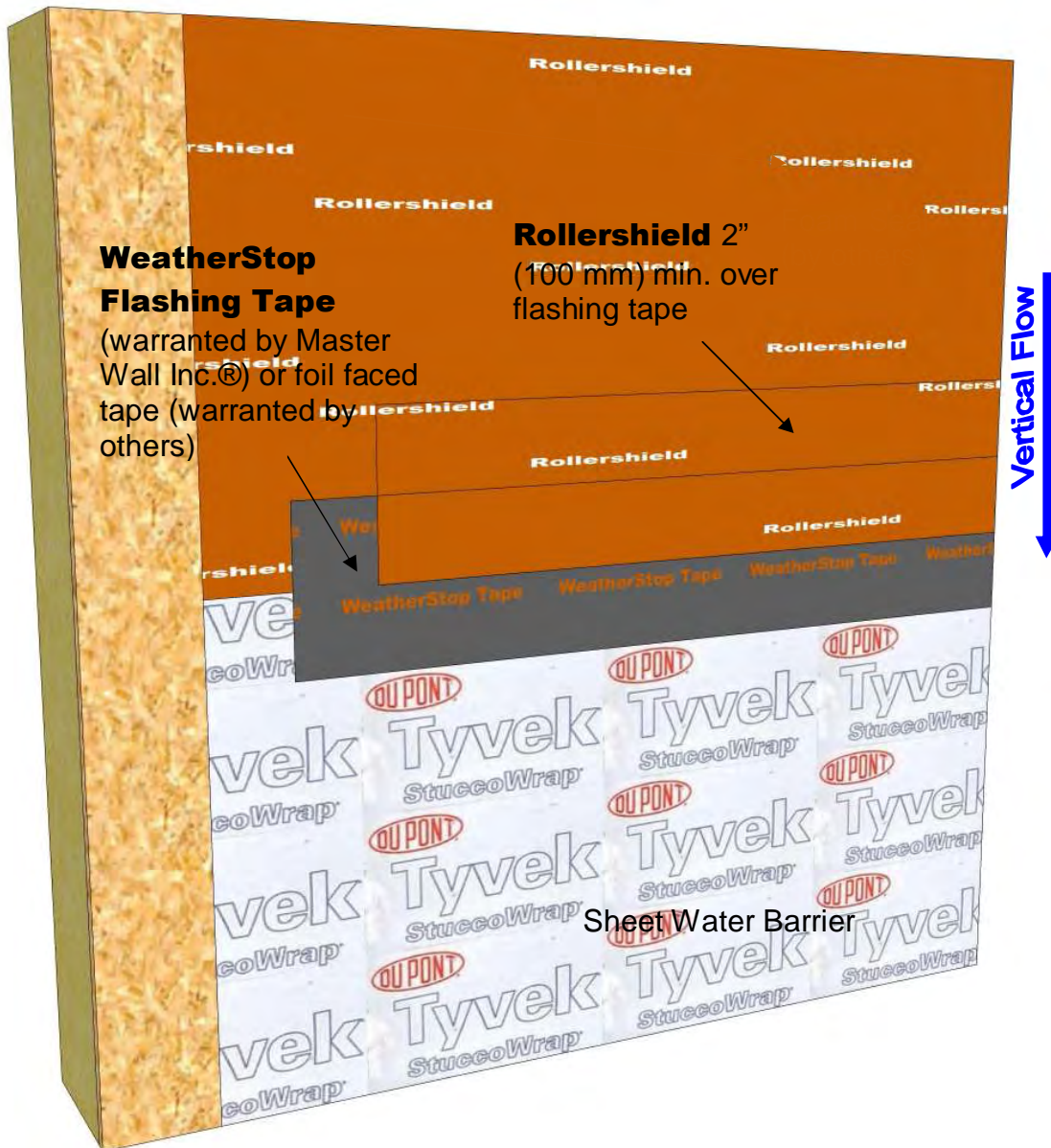

RSLAB-23 Transition to Sheet Water Barrier

These drawings relay the conceptual conditions of Master Wall® Systems and are not the construction drawings. Ultimately the design and detailing of an entire wall system is the responsibility of a professional. These details will guide the design professional in the use of Master Wall® Products. Master Wall disclaims design, warranty or construction intent or responsibility. **Bold or brand name = Master Wall® Product.** ©2014 Master Wall Inc.



Rollershield LAB

Liquid Applied Air/Water Barrier

Notes:

1. Angle kick-out flashing 100° minimum to allow for drainage
2. Kick out flashing seams must be soldered or sealed with appropriate sealant.
3. **Rollershield** should cover the step flashing a minimum of 2" (51 mm) and siding should be placed about 1" to 2" (25-51 mm) above the roofline in accordance with local requirements.

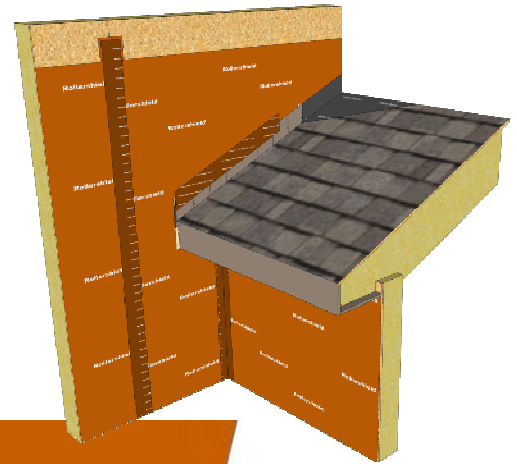

RSLAB-24 Typical Roof/Wall Intersection

These drawings relay the conceptual conditions of Master Wall® Systems and are not the construction drawings. Ultimately the design and detailing of an entire wall system is the responsibility of a professional. These details will guide the design professional in the use of Master Wall® Products. Master Wall disclaims design, warranty or construction intent or responsibility. **Bold or brand name = Master Wall® Product.** ©2014 Master Wall Inc.



Rollershield LAB

Liquid Applied Air/Water Barrier

**Rollershield with
Rollershield Flashing
Tape** centered at
transition

Roofing

Coping Cap with
continuous cleat –
extend 2" min over
EIFS and stucco and
seal lower edge.
Follow
manufacturer's
recommendations
for other siding
materials

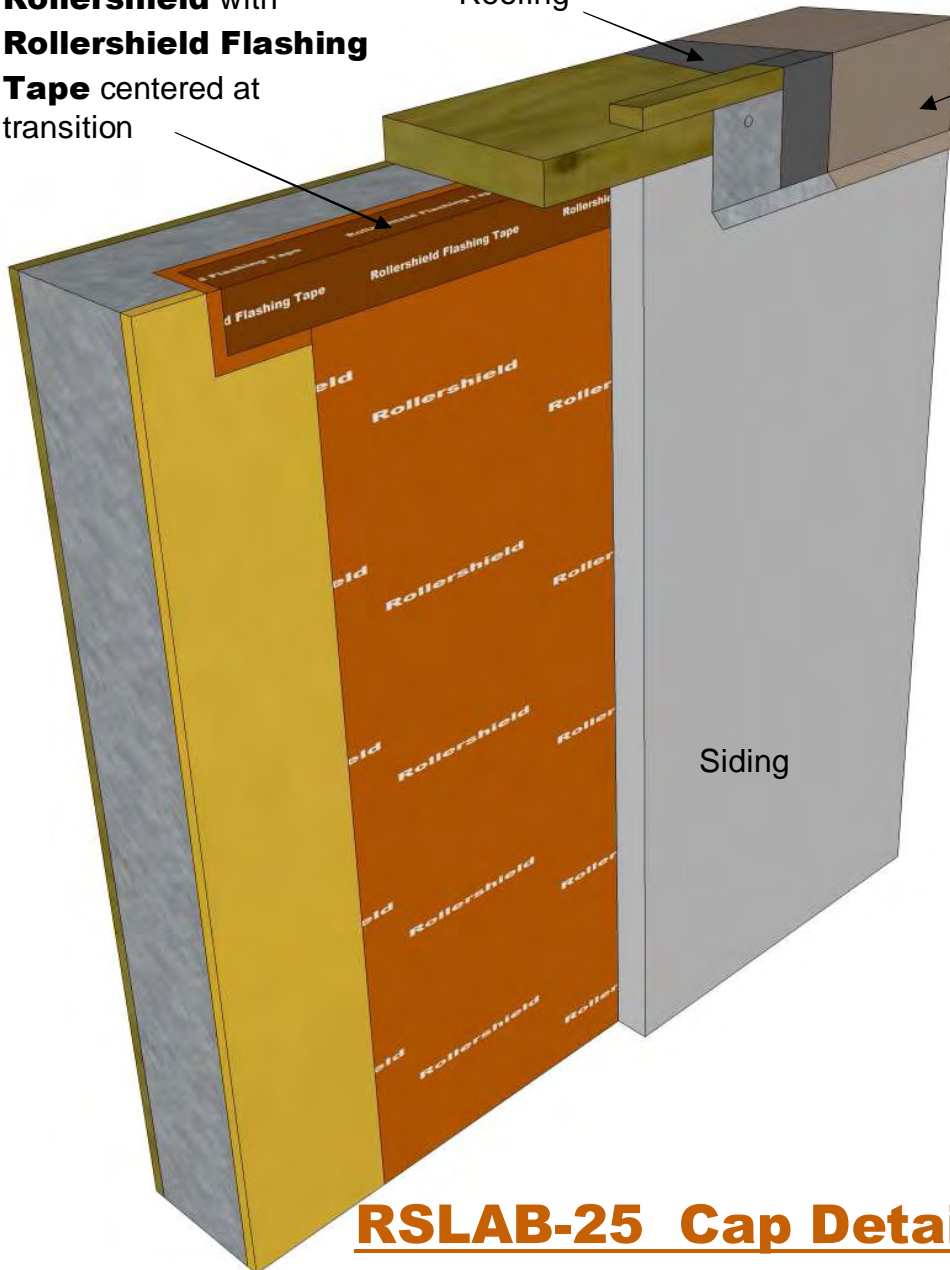

RSLAB-25 Cap Detail

These drawings relay the conceptual conditions of Master Wall® Systems and are not the construction drawings. Ultimately the design and detailing of an entire wall system is the responsibility of a professional. These details will guide the design professional in the use of Master Wall® Products. Master Wall disclaims design, warranty or construction intent or responsibility. **Bold or brand name = Master Wall® Product.** ©2014 Master Wall Inc.