



Quick Set MBB Adhesive & Base Coat

Systems

Aggre-flex EIFS
Aggre-flex Drainage EIFS
Cemplaster Fiberstucco
ICF Coatings
QRW1 Drainage EIFS
Rollershield Drainage CIFS®
Soffit System
Stucco Cement Board Coatings
Uninsulated Finishes

VOC: 0

**Shipping Locations:
30058 • 77474 • 84651**

**Packaging: 50lb (22.7kg)
bag**

Shelf Life: 1 year

**Coverage (estimated)
Adhesive & Standard Base
Coat: 50-60 sf (4.6-536 sm)**

**Embedding Single-layer of
Mesh: 100-125 sf (9-11.5 sm)**

**Double Layer of Mesh: 30-110
sf (2.5-10 sm)**

**Notched Trowel Adhesive
Application: 56 sf (5.2 sm)**

To **finish** fast you need a fast setting base coat. **Master Wall® Quick Set Bagged Base (QSMBB)** is a fast-



setting dry polymer acrylic formulated high performance base coat and adhesive used in Master Wall® Systems or over prepared substrates including brick, masonry, concrete and stucco.

- Adheres insulation board to approved substrates
- Excellent water resistance
- Freeze stable in dry form
- Convenient, mixes with water
- Base coat for Aggre-flex Mesh

Product Test Standards

ASTM C67, ASTM C297, ASTM D897, ASTM D2247, ASTM E2489/EIMA 101.86, ASTM D5420, ASTM E96, ASTM E330, ASTM E331, ASTM E2273, ASTM E2485, ASTM E84, IBC 1403, NFPA 268

 **Master Wall Inc.®**
Building a Culture of Excellence
masterwall.com

PO Box 397 • Fortson • GA • 31808 • 800-755-0825 • Tech: 800-760-2861



Quick Set MBB Adhesive & Base Coat

Temp: 40°-110°F (5°-43°C) • Working Time: 3/4 hr • Dry Time: 3-4 hrs (adhesive), 2 hrs (base coat) at room temperature, working and drying time will vary with temperature and humidity

Application Procedure

Job Conditions - Air and substrate temperature for application of Quick Set MBB (QSMBB) must be 40°F (5°C) or higher and must remain 40°F (5°C) or higher for a minimum of 24 hours. Provide temporary protection to protect the wall system from damage until permanent flashings, caps and sealants are installed. Store materials within prescribed temperature limits and out of direct sunlight. Working and drying times are based upon normal room temperature conditions and will vary with temperature and humidity.

Preparation - The substrate must be approved by Master Wall Inc.[®], clean, dry, structurally sound and free of efflorescence, oil, grease, form release agents and curing compounds or anything that would affect bond. Painted surfaces are not acceptable and must be removed.

Mixing - Add 5 to 6 quarts (4.7-5.7L) of potable water to a clean plastic pail. Add the QSMBB slowly while stirring using a heavy-duty 1/2" (12.7 mm) drill at 400 - 500 rpm and a Heavy Duty Mixer. Mix thoroughly to a homogenous consistency. Let the mixture stand for 3 to 5 minutes and then stir to a creamy consistency. Small amounts of clean, potable water may be added to obtain a workable consistency. Do not over mix. Excessive stirring may cause faster setting and reduced working time. Do not add accelerators or retarders to the QSMBB mixture.

Application

Adhesive application – Over gypsum substrates, apply the QSMBB mixture directly to the back of the insulation board using a 3/8"x3/8"x3/8" (9.5x9.5x9.5 mm) or a 3/8"x1/2"x1-1/2" (9.5x13x38 mm) stainless steel notched trowel. With the trowel at a 45° angle, cover the entire back of the insulation board with full beads of adhesive. Apply the adhesive so the ribbons run vertically when applied to the wall.

Over non-gypsum substrates, you may use the above described notched trowel method or the 'ribbon and dab' method. Using a stainless steel plastering trowel, apply a 2" (50.8 mm) wide by 3/8" (9.5 mm) high ribbon of the QSMBB mixture around the entire perimeter of the insulation board. Place 8 dabs of the QSMBB mixture 3/8" (9.5 mm) thick by 4" (102 mm) in diameter approximately 8" (204 mm) on center inside the ribbon.

Immediately place the prepared insulation board on the substrate. Make sure that all edges of the insulation board are abutted tightly and that no QSMBB mixture gets into the board joints. Do not allow the QSMBB mixture to form a skin prior to placing the insulation board on the substrate. Do not apply the QSMBB mixture directly onto the substrate.

For base coat application – All imperfections in the insulation board must be rasped flush and any gaps in the insulation board must be filled with slivers of insulation. Apply the QSMBB mixture over the entire surface of the insulation board in a thickness greater than that of the reinforcing fabric being used (approximately 1/16" (1.6 mm) for standard mesh and 3/32" (2.4 mm) for Ultra Mesh). Immediately embed the reinforcing fabric into the wet QSMBB mixture and smooth from the center to the edge to avoid wrinkles. The reinforcing fabric must be continuous at all corners and lapped or abutted in accordance to Master Wall[®] specifications. The color of the mesh shall not be visible but a slight mesh pattern may be visible.

Clean Up—Tools and equipment can be cleaned with soapy water while the QSMBB is still wet.

WARNING, THIS PRODUCT CONTAINS SILICA

If sanding or scraping are performed, ventilate work area and/or use a NIOSH/MSHA-approved respirator in accordance with our Safety Data Sheet.

Approved Substrates

Exterior gypsum sheathing (ASTM C1396, C1177)

Dens Glass Gold[®]

GlasRoc[®]

FiberBond[®]

Gold Bond e2xp[®]

Securock[®]

Weather Defense Platinum[™]

Durock[®]

PermaBase[®]

Util-A-Crete[®]

ProTEC[®], ProGUARD[®]

Concrete

Brick

Masonry

Metal Lath

Adheres to Rollershield

Others approved in writing

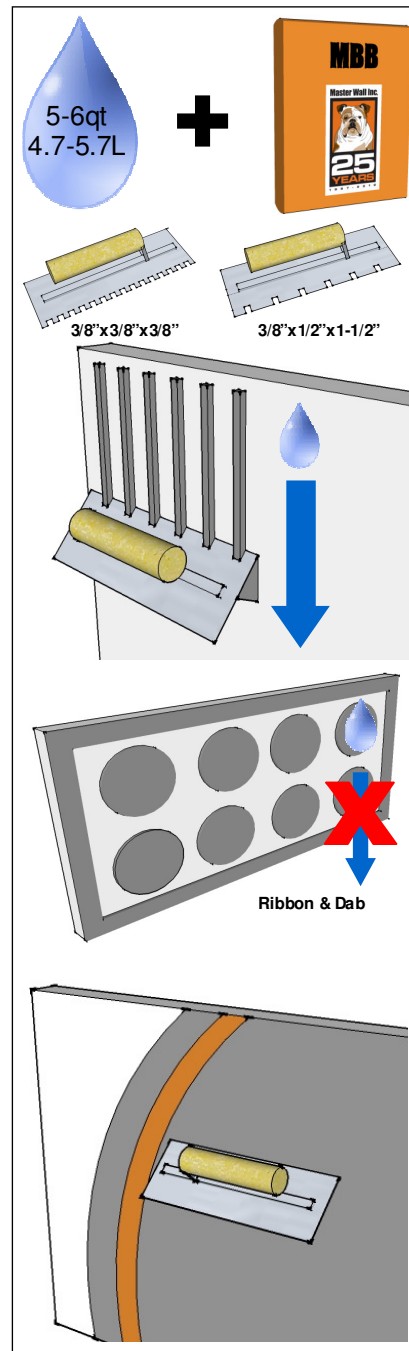

Information contained in this product data sheet conforms to the standard detail recommendations and specifications for the installation of Master Wall Inc.[®] products and is presented in good faith. Master Wall Inc.[®] assumes no liability, expressed or implied as to the architecture, engineering, or workmanship of any project. This information may be concurrent with, or superseded by other applicable documents, such as specifications and details. Contact Master Wall Inc.[®] for the most current product information. ©2018 Master Wall Inc.[®]

Master Wall Inc.[®]
Building a Culture of Excellence
masterwall.com

PO Box 397 • Fortson • GA • 31808 • 800-755-0825 • Tech: 800-760-2861