

# Project Submittal Package



Project:

Location:

Architect:

General Contractor:

Applicator:



## Master Wall Inc.®



[System Data Sheets](#)   [Product Data Sheets](#)   [Sample Warranty](#)  
[Specifications](#)   [Details](#)   [Web Link \(click here\)](#)

PO Box 397

Fortson

GA

31808

800-755-0825

[masterwall.com](http://masterwall.com)

## LiMa W120 Light Masonry Wall System

The LiMa W120 thin brick and stone system is an interior thin brick system for us where moisture may be a concern.

It features our Rollershield air and water barrier product that is either rolled, sprayed or troweled in place. With any method, the product offers excellent water holdout capabilities compared to a sheet good and has class-leading air sealing capability.

The UltraBond adhesive has class leading slump resistance and cures quickly to quickly get your wall system in service.

CIFS® Brick Mortar is available in four colors and mixes easily.

### Features & Benefits

- 20-year limited warranty
- Extremely low air infiltration properties
- Rollershield seals around nail holes
- Rollershield options
  - Rollershield-RS, vapor open roll grade
  - Rollershield-TG, vapor open trowel grade
  - Rollershield-VB vapor closed roll grade
- Drainage mat provides extra drainage capability
- Quality products with great durability

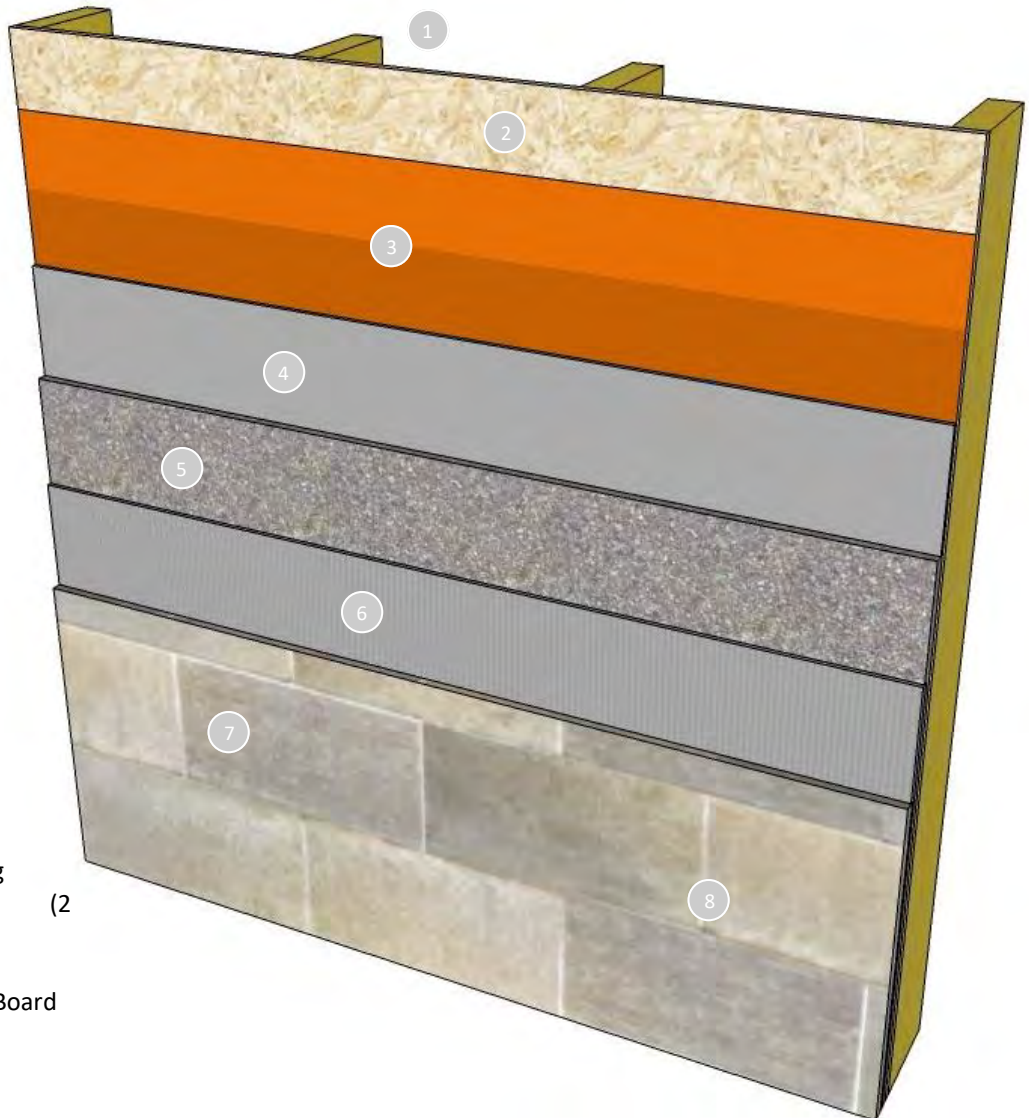

1. Wood or Metal Framing
2. Wood or other approved sheathing
3. Rollershield  
coats or 22 mils dry thickness)
4. Keene Drainage Mat 020-1
5. 1/2" or 5/8" PermaBase® Cement Board
6. UltraBond Adhesive
7. Thin Brick or Stone
8. CIFS® Brick Mortar

## LiMa W120 Light Masonry Wall System

### LiMaW120 Specification

#### Section 04 70 00

##### 1.0 General

This is a specification for the application of a Master Wall® Light Masonry (LiMa) application over wood or metal framing and sheathing on a building interior.

##### 1.1 System Description

The Master Wall® LiMaW120 is a light masonry stone or thin brick application over cement board. It uses two coats of SuperiorShield Rollershield as the air and water barrier and a drainage mat under the cement board with UltraBond as the adhesive for ICC-ES AC51 compliant stone or thin brick with CIFS® Brick Mortar.

##### 1.2 Design Requirements:

- A. Reference Master Wall® suggested details and architectural drawings for specific detail requirements.
- B. Slope all surfaces a minimum of 1:2 (6" in 12") to shed water, maximum 12" (305mm) wide.
- C. Maximum deflection of substrates shall not exceed L/600.
- D. Typical acceptable substrates include CDX exterior grade plywood, Exposure 1 Oriented Strand Board (OSB).
- E. Expansion joints are required in the cladding at building expansion joints, panel joints, floor lines in wood framed construction, and other areas where significant movement occurs.

##### 1.3 Quality Assurance

- A. The Rollershield air/water barrier shall be recognized in IAPMO ER-0384.
- B. SuperiorShield product bulletins, application instructions and details.
- C. National Gypsum PermaBase® installation instructions and code report.

##### 1.4 Job Conditions

- A. Store all materials protected from weather and direct sunlight at temperatures above 40°F (5°C).
- B. The ambient and wall temperature shall be a minimum of 40°F (5°C) and shall remain so for at least 24 hours after installation.

##### 1.5 Warranty

- A. Application shall include a 20-year limited warranty, please reference the LiMa Warranty Program Limited Warranty.

##### 2.0 Products

All components of the LiMa application shall be manufactured by Master Wall® and supplied by an authorized distributor.

##### 2.1 SuperiorShield Water Barrier & Flashing Tapes:

- A. SuperiorShield Rollershield RS: A 100% pure acrylic-based roll-applied weather-resistive barrier.
- B. SuperiorShield Rollershield TG: A 100% pure acrylic-based trowel grade water-resistive barrier.
- C. SuperiorShield Rollershield VB: Acrylic-based vapor barrier water resistive barrier.
- D. SuperiorShield Flashing Tape: A lightweight nonwoven joint treatment material.
- E. SuperiorShield Mesh Tape: A lightweight joint treatment material.
- F. SuperiorFlash: A single-component fluid applied flashing.

##### 2.2 Drainage Mat: Keene Driwall™ Rainscreen 020-1.

##### 2.3 Cement Board: National Gypsum PermaBase® in 1/2" (12.7 mm) or 5/8" (15.9 mm) thickness along with recommended fasteners.

##### 2.4 Master Wall® Stone/Thin Brick Adhesive: UltraBond, A ready to use dry base adhesive that is field mixed with water.

##### 2.5 CIFS® Brick Mortar: A ready to use dry base mortar that is field mixed with water.

##### 3.0 Installation

##### 3.1 Inspect the substrate to ensure that it is free of all foreign materials that would affect the adhesion of the Rollershield air and water barrier.

##### 3.2 Apply the Rollershield products in accordance with the product data sheets, minimum two coats or a single coating with a dry mil thickness of at least 22 mils.

##### 3.3 Mechanically fasten rainscreen with a cap nail, cap staple, or cap screw; one fastener for each square foot following Keene instructions. DO NOT FASTEN THROUGH FLASHING.

##### 3.4 Attach cement board to framing members using approved fasteners at a minimum of 8" (20 cm) centers.

##### 3.5 Adhere ICC-ES AC51-compliant stone or thin brick using UltraBond, mixed following data sheet instructions. Allow to cure before proceeding with mortar application.

##### 3.6 Mortar with CIFS® Brick Mortar, mixed with water following data sheet instructions. Place in joints using a grout bag or similar device and rake/tool when thumb print hard.

##### 3.7 Allow the wall system to cure and protect from weather for at least 72 hours before placing in service.

Information contained in this product data sheet conforms to the standard detail recommendations and specifications for the installation of Master Wall Inc.® products and is presented in good faith. Master Wall Inc.® assumes no liability, expressed or implied as to the architecture, engineering, or workmanship of any project. This information may be concurrent with, or superseded by other applicable documents, such as specifications and details. Contact Master Wall Inc.® for the most current product information. ©2020 Master Wall Inc.®



**masterwall.com**

PO Box 397 • Fortson • GA • 31808 • 800-755-0825



**Master Wall Inc.®**  
Building a Culture of Excellence

## PRODUCT DATA

### SUPERIORSHIELD ROLLERSHIELD-RS

SuperiorShield Rollershield-RS is a high quality 100% acrylic flexible fluid applied air and water barrier that is easily applied with a roller or spray equipment but also can be troweled or brushed into place. Rollershield-RS forms a continuous air and water barrier that protects approved substrates from incidental water damage.

#### FEATURES & BENEFITS

- Used as an air/water barrier or as part of the Rollershield Drainage CIFS® System
- 100% Coverage, Fully adhered to substrate
- Vapor open/permeable with low air infiltration rate
- Used as water barrier and flashing, 60-minute Grade D equivalent
- Compatible with other SuperiorShield products; Rollershield-TG (Trowel Grade), Rollershield-VB, SuperiorFlash and WeatherSTOP Tape
- Adheres to most common building materials
- Easy to apply, water based for easy cleanup
- Exposure up to 6 months
- Low VOC, <1% by weight, 10 g/L

Application Temperature: 40° -110°F (5° -43°C)

Dry to Touch: 1 hour @ room temperature

Recoat Time: 2 hours @ room temperature

Drying Time: 12 hours @ room temperature, working and drying time will vary with temperature and humidity.

#### JOB CONDITIONS

Air and substrate temperature for application of Rollershield-RS must be 40°F (5°C) or higher and must remain 40°F (5°C) or higher for a minimum of 24 hours. Provide temporary protection to protect the wall system from damage until permanent flashings, caps and sealants are installed. Store materials within prescribed temperature limits and out of direct sunlight. Working and drying times are based upon normal room temperature conditions and will vary with temperature and humidity.

#### PREPARATION

The substrate must be approved by Master Wall Inc.®, clean, dry, structurally sound, and free of efflorescence, oil, grease, form release agents and curing compounds or anything that would affect bond. Painted surfaces are not acceptable and must be removed or bond test performed. Substrates must be flat and free of fins or planar irregularities greater than 1/4" in 10'-0" (6.35 mm in 3.05 m).

#### Coverage per pail (sf/sm)\*

Roller: 450-500 sf (42-46 sm)

Spray: 300-350 sf (28-32.5 sm)

Trowel: 200-250 sf (18-23 sm)

*\*All coverage is approximate and depend upon substrate, details and individual application*

#### Packaging/Shelf Life/Storage

Packaging: 5 gallon (19L) pail

Product Color: Naranja Durazno

Shelf Life: 2 years

Storage: Protect from extreme heat (90°F (32°C)), freezing and direct sunlight.

#### Technical Data

Solids Content: 69.52% solids by wt (55.05% by vol)

Tensile Bond, ASTM C297/E2134/AC212: 30-200 psi

Freeze-thaw ASTM E2485/AC212: Pass

Water Resistance, ASTM D2247/AC212: Pass

Water Vapor Transmission, ASTM E96 Proc. B/AC212: 30 perms\*\* @ 10 mils, 15 perms @ 20 mils

Air Permeance, ASTM E2178: 0.001 cfm/ft2 @ 1.57 psf, 0.001 L/s/m2 @ 75 Pa

Air Leakage, ASTM E2357: 0.0006 cfm/ft2 @ 1.57 psf (0.003 L/s/m2 @ 75 Pa), 0.04 cfm/ft2 @ 6.24 psf (0.02 L/s/m2 @ 300 Pa)

Structural Performance, ASTM E1233/AC212: Pass

Racking, ASTM E72/AC212: Pass

Restrained Environmental, AC212: Pass

Water Penetration, ASTM E331/AC212: Pass

UV Exposure: Rated to 6 months

Accelerated Aging, AC212: Pass

Hydrostatic Pressure Test, AATCC 127/AC212: Pass

Surface Burning Characteristics, ASTM E84: Flame Spread < 25, Smoke Developed < 450

Intermediate Multi-Story Fire Test, NFPA 285 (UBC 26-9): Pass

Nail Sealability, ASTM D1970: Pass @ 22 mils

Heat and Smoke Release Rates, ASTM E1354, IBC Section 1403.5: Peak Heat Release Rate = 32 kW/m2, Total Heat Release Rate = 3.6 MJ/m2, Effective Heat of Combustion = 2.5 MJ/kg

\*\* Defined as a Class III vapor retarder per IBC and IRC

## APPLICATION PROCEDURE

Concrete – Must have cured a minimum of 28 days prior to the application of Rollershield-RS. If form release agents or curing compounds exist on the surface, they must be removed with a solution of muriatic acid or similar product (with appropriate precautions). Remove any residual acid by flushing with water.

Brick/Masonry – If joints are not struck flush, multiple coats may be required. Porous CMU may require additional coats.

Sheathing Applications - Sheathing gaps must be less than 1/4" (6.4 mm). See Technical Bulletin #189 for larger gap suggestions. Gap wood-based sheathing per manufacturers recommendations, typically 1/8" (3.2 mm) minimum.

Mixing - Thoroughly stir Rollershield-RS into a homogenous consistency. Do not add water, over mix, or add accelerators or retarders to the product.

Application – Rollershield-RS is applied by first treating the joints and fastener locations where sheathing is used, then coating the entire surface using brush, roller, trowel, or airless spray equipment techniques. When using a foam roller, a maximum 3/4" (19 mm) nap is recommended. Apply in an even, continuous coat, maintaining a wet edge of approximately 15 mils thickness. Oriented Strand Board and other porous substrates will require two (2) coats of Rollershield-RS. For moisture protection, apply Rollershield-RS as a continuous barrier of 10 mils dry thickness with no breaks or skips, although some areas will appear lighter than others due to the application process. The application need not look like a painted surface.

Joint Treatment—Apply a thin layer of Rollershield-RS to the joints and embed SuperiorShield Flashing Tape into the wet mixture and trowel smooth. Alternatively place and center SuperiorShield Mesh over all joints, corners, and gaps in the substrate. Immediately apply Rollershield-RS over the mesh and allow to dry.

Rollershield-RS may be flashed into window, door and other openings using the same techniques for sheathing applications. Any remaining gaps should be filled with additional Rollershield-RS, TG (Trowel Grade) or SuperiorFlash.

Wall Treatment—Apply Rollershield-RS to the wall surface using the foam roller, trowel or by spray applying and backrolling to a uniform thickness of 15 mils wet, 10 mils dry with no pinholes or voids.

## LIMITATIONS

Not for use as an exterior finish, note exposure limitations on front page.

When adhering Rollershield Drainage CIFS® to the surface assure it is clean, dry, and free of surface contamination. Remove any dirt or surface contamination before adhesive attachment.

Allowable in-service temperature range: -40° to 180°F (-40° to 82°C).

Fire-retardant or pressure treated plywood must be dry with surface free of salts or other chemicals migrating from within the wood. Test adhesion to be sure of desired results.

Use a slip sheet, typically one layer of building paper between Rollershield-RS and stucco or adhered masonry veneer over metal lath.

**Hazard:** This chemical is not considered hazardous according to the OSHA Hazard Communication Standard 2012 (29 CFR 1910.1200).

### Approved Substrates

Exterior gypsum sheathing (ASTM C1396)

Glass Fiber Exterior Sheathing (ASTM C1177): Dens Glass Gold®, GlasRoc®, FiberBond®, Gold Bond e2xp®, etc.

Cement Board Substrates (ASTM C1325): Durock®, PermaBase®, ProTEC®, SelectCrete, Util-A-Crete®, etc.

Concrete

Brick

Masonry

Exterior Plywood

Oriented Strand Board (OSB)

Huber Zip (See Data Sheet for Specifics)

Most metals and PVC

Others approved in writing

### Compatible SuperiorShield Components

Rollershield-TG

SuperiorFlash

SuperiorShield Flashing Tape

SuperiorShield Mesh

WeatherSTOP Tape

### Sealant Bond Compatibility\*\*

*Adfast Corp.:* Adseal DWSP1940 Series\*\*\*, Adseal 4600, Adseal 4580, Adseal 1940

*Dow Corning:* 795 Silicone\*\*

*Pecora Corp.:* 864NST, 890NST, 890FTS, 895NST<sup>A</sup>, Dynatrol I-XL Hybrid<sup>B</sup>

Sika: Silaflex 15 LM\*\*\*, Silaflex-2C NS\*\*\*

Master Builders Solutions: MasterSeal NP1\*\*\*

Tremco: Dymonic 100\*\*\*

Most polyurethane sealants\*\*

See Technical Bulletin MW#131 for latest sealant information

\*\*field verify bond (varies)

\*\*\*Also bonds to SuperiorFlash

<sup>A</sup>With P120 Primer with Rollershield RS & TG

<sup>B</sup>With P120 Primer with Rollershield VB

## SPRAY APPLICATION

Rollershield-RS is compatible with GRACO and Titan airless spray equipment with the following specifications:

- Minimum 1 gallon per minute output.
- Minimum hose width of 3/8 inch.
- Minimum tip size of 0.027–0.031.

Minimum pressure requirement to spray of 2,000 psi at the gun with an airless sprayer rated no lower than 3,300 psi. Remove all filters in sprayer and gun before application.

Hopper Gun: 3/16"-1/4" (6-6.5 mm) orifice, 23-25 psi.

## CLEAN UP

Tools and equipment can be cleaned with soapy water when Rollershield-RS is wet.

Information contained in this product data sheet conforms to the standard detail recommendations and specifications for the installation of Master Wall Inc.<sup>®</sup> products and is presented in good faith. Master Wall Inc.<sup>®</sup> assumes no liability, expressed or implied as to the architecture, engineering, or workmanship of any project. This information may be concurrent with, or superseded by other applicable documents, such as specifications and details. Contact Master Wall Inc.<sup>®</sup> for the most current product information. ©2022 Master Wall Inc.<sup>®</sup>



## Health & Safety

### WARNING!

Causes eye and skin irritation.

Precautionary Statement

Wash hands thoroughly after handling. Wear protective gloves/protective clothing/eye protection/face protection.

### FIRST AID MEASURES

Eye: Contact Rinse thoroughly with water as necessary. Get medical attention immediately if symptoms occur.

Skin: Contact Wash off with water. Consult a physician if necessary.

Inhalation: Move to fresh air. If symptoms arise, call a physician.

Ingestion: Clean mouth with water and afterwards drink plenty of water. Do NOT induce vomiting.

Consult a physician. Never give anything by mouth to an unconscious person.

Store locked up. Dispose of contents/container in accordance with Local, State, Federal and Provincial regulation.

Spills: Collect with suitable absorbent material such as cotton rags.

Disposal: Dispose of in accordance with local, state or federal regulations.

Warning: KEEP CONTAINER CLOSED WHEN NOT IN USE. KEEP OUT OF THE REACH OF CHILDREN. NOT FOR INTERNAL CONSUMPTION. FOR INDUSTRIAL USE ONLY.

Consult the Safety Data Sheet (SDS) in the Products section at [masterwall.com](http://masterwall.com) for further health and safety information.

### LIMITED WARRANTY

This product is subject to a written limited material or system warranty. Obtain a warranty from the Tech Support tab of our website. Refer to Specifications for more complete information on proper use and handling of this product.



**Master Wall Inc.**  
Building a Culture of Excellence

## PRODUCT DATA

### SUPERIORSHIELD FLASHING TAPE

Lightweight non adhesive roll flashing material with superior strength and the ability to bridge most gaps or voids common in construction. Embedded into wet Rollershield-RS, TG or VB, it is used at flashing transitions with Master Wall® SuperiorShield Liquid Air/Water Barrier (LAB) and as part of Rollershield Drainage CIFS® applications. The tape easily embeds into wet Rollershield and dries to a highly reinforced yet flexible flashing.

#### FEATURES & BENEFITS

- Lightweight
- Strong
- Embeds easily
- Thin, will not build up wall surface
- Compatible with Rollershield RS, TG, VB and SuperiorFlash products

#### JOB CONDITIONS

Air and substrate temperature for application of SuperiorShield Flashing Tape must be 40°F (5°C) or higher. Follow Rollershield-RS, TG or VB temperatures and condition requirements.

#### PREPARATION

General—The substrate must be clean, dry, structurally sound, and free of efflorescence, oil, grease, form release agents and curing compounds. Test painted surfaces to verify bond.

Temporary Protection – Protect from weather until the Rollershield-RS, TG or VB products have set up.

Surface Preparation - Surface temperature must be above 40°F (5°C). Surface must be cured, clean, dry, structurally sound, and free of efflorescence, oil, grease, form release agents, and curing compounds.

#### Coverage estimate\*

4x8 sheets: Square Footage x 0.37 = linear feet of tape

Add linear footage around windows, doors, and other openings.

*\*All coverage is approximate and depend upon substrate, details and individual application*

#### Roll Sizing/Packaging/Shelf Life/Storage

4"x180' (10.2cm x 54.9m)

6"x180' (15.2cm x 54.9m)

9"x180' (22.9cm x 54.9m)

Packaging:

4": 18 rolls per case.

6" & 9": 12 rolls per case.

Shelf Life: 2 years plus

Storage: Protect from extreme heat (90°F (32°C)), and direct sunlight.

## APPLICATION PROCEDURE

General - SuperiorShield Flashing Tape is embedded into wet Rollershield-RS, TG or VB at flashing transitions (sheathing to framing, flashing, penetrations, etc.) and at sheathing board joints. Apply a generous layer of the product using a trowel, brush or roller and immediately embed the SuperiorShield Flashing Tape into the product and draw it tight and smooth working from the center to the edges.

Windows – The unique properties of the SuperiorShield air/water barrier system allows window flashing prior to the Rollershield wall application. Apply Rollershield and center SuperiorFlash Flashing Tape to provide at least at least 1” (25 mm) bond to the window flange and substrate on either side of the window opening. Use a “butterfly” at corners to complete the application making sure it covers all corner joints. For best results make sure the Rollershield covers the entire head, jamb, and sill areas. The use of sill wedges or water stops is encouraged.

Sheathing Applications – Apply Rollershield at least 2” (51 mm) either side of the sheathing board joint. Immediately embed the SuperiorShield Flashing Tape into the wet Rollershield and smooth with a trowel, centering it over the joint. Provide at least at least 1” (25 mm) bond either side of the sheathing joint. Lap Rollershield Mesh Tape 2” (51 mm) minimum Rollershield field application can begin as soon as the Rollershield is dry to the touch.

Information contained in this product data sheet conforms to the standard detail recommendations and specifications for the installation of Master Wall Inc.® products and is presented in good faith. Master Wall Inc.® assumes no liability, expressed or implied as to the architecture, engineering, or workmanship of any project. This information may be concurrent with, or superseded by other applicable documents, such as specifications and details. Contact Master Wall Inc.® for the most current product information. ©2022 Master Wall Inc.®



**Hazard:** This chemical is not considered hazardous according to the OSHA Hazard Communication Standard 2012 (29 CFR 1910.1200).

**VOC:** Less than 50 g/L.

### Approved Materials for Embedment

Rollershield-RS  
Rollershield-TG  
Rollershield-VB  
Others approved in writing

### LIMITED WARRANTY

This product is subject to a written limited material or system warranty. Obtain a warranty from the Tech Support tab of our website. Refer to Specifications for more complete information on proper use and handling of this product.

220701



Product Data

# Driwall™ Rainscreen 020-1 (6mm)

A Drainage and Ventilation Mat

## Description

Driwall™ Rainscreen 020-1 6mm is a nominal 0.25-inch, randomly oriented, geometric patterned drainage and ventilation mat.

It is designed to eliminate moisture and moisture vapor in masonry and other siding. Driwall™ Rainscreen is produced from an extruded polymer matrix of tangled monofilaments. The three-dimensional mat is heat-laminated to a non-woven lightweight, breathable fabric in order to provide a separation from cementitious sidings. The monofilaments are heat-welded at the junctions to form a structure that spaces exterior veneer away from the inner sheathing.

The product is useful in cavity wall designs and rainscreen systems in which an airspace is needed for drainage and ventilation. When DRIWALL™ RAINSCREEN is used, no mortar or other debris can enter the cavity, which ensures proper drainage and ventilation.

## Applications

- ✓ Stucco
- ✓ Thin stone or brick
- ✓ Manufactured stone
- ✓ Stone and brick masonry
- ✓ Fiber cement board siding
- ✓ Wood siding

## Features and Benefits

Driwall Rainscreen products PASS multiple wall assemblies that require NFPA 285

Drainage of excess moisture and ventilation in one product

Lightweight and easy to handle

Simple installation with mechanical staple hammer

Polymer core is resistant to most known corrosive chemicals, including solvents

Wide rolls for fewer seams

Core ABSORBS and RELEASES NO MOISTURE

Provides no source for the promotion of MOLD, MILDEW or BACTERIA

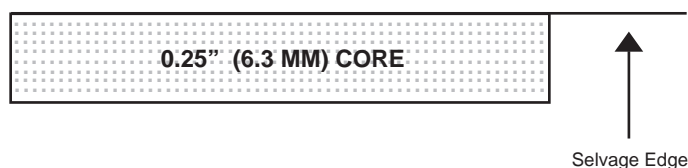

## Physical Properties

Description	Means of Measurement English/Metric		Value English/Metric	
Flame Spread	ASTM E84		Class A	
Core Polymer	Polymeric			
Thickness	in.	mm	0.25	6.3
Total Weight	oz/yd <sup>2</sup>	g/m <sup>2</sup>	12.7	403.6
Core Weight	oz/yd <sup>2</sup>	g/m <sup>2</sup>	10.8	366.2
Fabric Weight	oz/yd <sup>2</sup>	g/m <sup>2</sup>	1.9	64.0

## Packaging

Description	Means of Measurement English/Metric		Value English/Metric	
Core Width	in.	mm	48.0	1,219.2
Length	ft	m	65.0	19.8
Area	sq ft	sq m	260	24.2
Roll Diameter	in.	mm	16.0	406.4
Roll Weight	lb	kg	19.5	8.8

See installation instructions for methods and procedures.

### 25 YEAR LIMITED WARRANTY

#### KEENE BUILDING PRODUCTS, INC. DRIWALL RAINSCREEN

Keene Building Products, Inc. ("Keene") warrants its DRIWALL RAINSCREEN products against defects in material and workmanship for a period of Twenty-Five (25) years from the date of installation. Upon receipt of written notice, which must be given no later than thirty (30) days after discovery of the defect, Keene, at its sole option, will repair or replace the defective item(s) or refund the purchase price. Keene, at its sole option, may request that the defective item(s) be returned to Keene's principal offices for investigation and inspection. Keene is not required to repair or replace the defective item(s) or to refund the purchase price until it has received such item(s) that Keene has requested returned and has inspected such item(s).

The warranty provided above is extended solely to the person or entity that purchases the product directly from Keene, and no third party may rely thereon or assert any claim based on such warranty. The foregoing warranty is the only warranty provided by Keene and is to the exclusion of any other warranty, whether express or implied, including the implied warranties of merchantability and fitness for a particular purpose, all of which are expressly disclaimed. Keene's liability, if any, for damages based on any claim of any kind whatsoever, and regardless of the legal theory, with regard to any of its products shall be limited to the actual purchase price of the product(s) with respect to which such claim is made.

UNDER NO CIRCUMSTANCES SHALL KEENE BE LIABLE TO PURCHASER FOR COMPENSATION, REIMBURSEMENT OR DAMAGES ON ACCOUNT OF THE LOSS OF PRESENT OR PROSPECTIVE PROFITS OR REVENUE, EXPENDITURES, INVESTMENTS OR COMMITMENTS, AND IN NO EVENT SHALL KEENE BE LIABLE TO PURCHASER OR ANY OTHER PERSON OR ENTITY FOR SPECIAL, INCIDENTAL, INDIRECT, CONSEQUENTIAL OR EXEMPLARY DAMAGES. By way of example only, Keene will not be responsible for any damages purchaser may incur that are related to surface, subsurface or building conditions, damage to the structure or contents of any building, or for costs of repair and replacement except as may be expressly provided in this Limited Warranty (and subject to the terms and conditions hereof).

Keene shall not be liable for product failure resulting from any of the following: (i) products not installed in accordance with Keene's installation instructions; (ii) non-compliance with applicable building codes and regulations; (iii) the use of any of its products (A) in a manner for which it was not intended; (B) in a modified form without the permission of Keene, or (C) in combination with any other system, equipment or device not manufactured or sold by Keene.

Keene may change, modify, amend, replace or discontinue offering a product warranty, limited or otherwise. Any such change, modification, amendment, replacement or discontinuance shall be applicable to unsold products only, and Keene shall endeavor to give purchaser at least thirty (30) days prior written notice of same.

Claims or inquiries shall be addressed as follows:

Customer Service Department [Quality Control Manager]  
 KEENE BUILDING PRODUCTS, INC.  
 2926 Chester Avenue  
 Cleveland, OH 44114  
 P 440 605 1020 [877-514-5336]  
 F 440 605 1120  
 www.keenebuilding.com



P.O. Box 241353

Mayfield Heights, OH 44124

Info@KeeneBuilding.com

KeeneBuilding.com

877 | 514 | 5336

P 440 | 605 | 1020

F 440 | 605 | 1120

# Cement Board Exterior Applications Guide

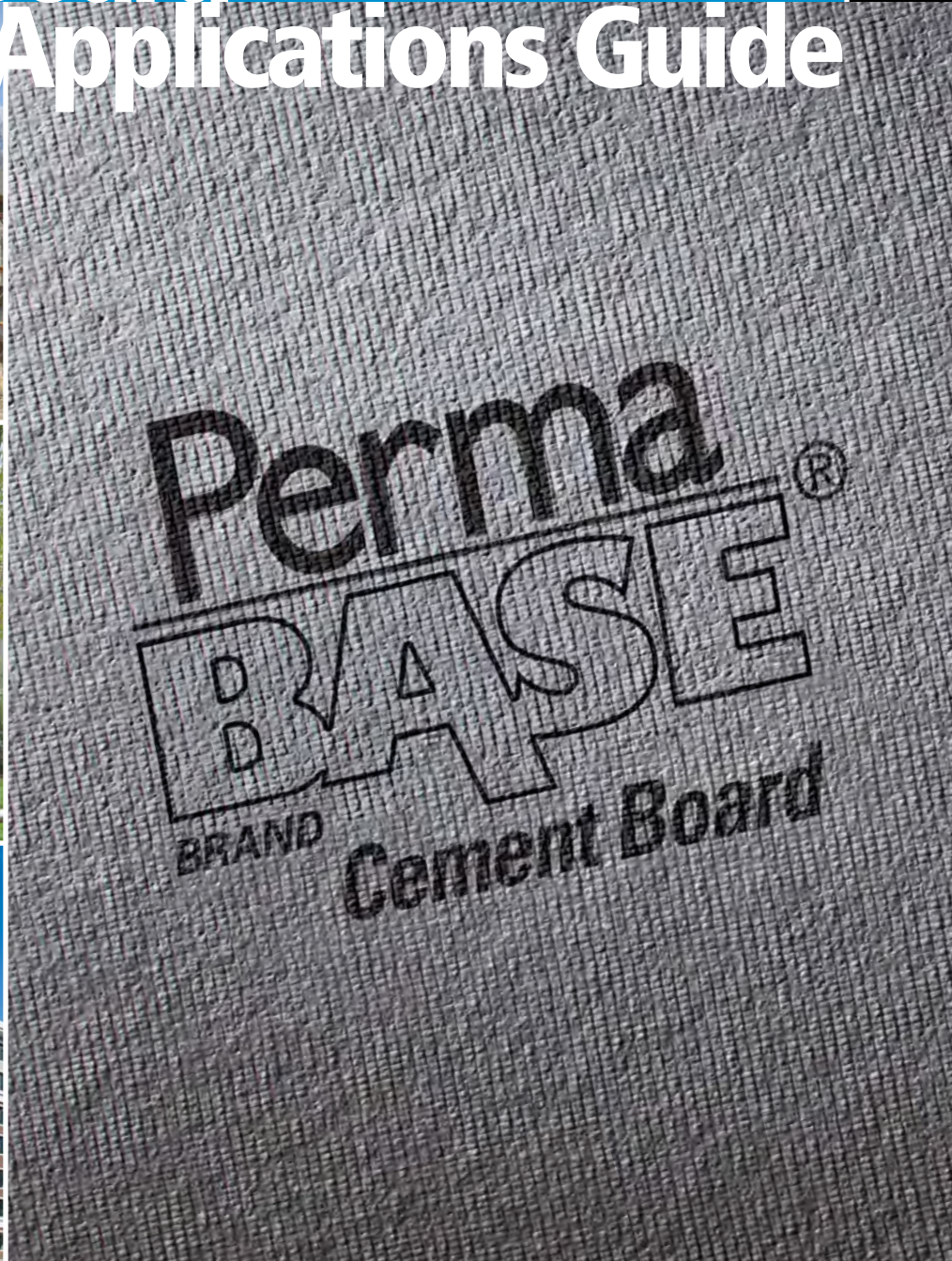

# Building In Strength And Quality

## Reinforce With The Best Rigid Substrate: PermaBase® BRAND Cement Board

PermaBase® provides a durable surface designed to withstand prolonged exposure to moisture. Made with Portland cement, aggregate and fiberglass mesh, it works well with exterior applications. Lightweight and easy to install, our EdgeTech® Technology allows a closer nail or screw application.



### Resists Moisture Better

- Stays intact when exposed to water: will not rot, disintegrate or swell – built for the long run
- Achieves the industry's lowest water-absorption rating (ASTM C 473) – offering better installation
- Helps inhibit mold growth with the highest possible score on mold tests (ASTM D 3273 and ASTM G 21)



### Stays Strong And Lasts Long

- Resists impact and remains dimensionally stable – extending the life of your project
- Holds up to the toughest conditions



### Installs Quickly

- Lightweight and easy to cut – speeding up installation
- Reduces jobsite waste – easier, cleaner cut
- EdgeTech® Technology allows for a closer edge fastening and reduces damage from handling



### Works For Exterior Projects – One Panel, Many Applications

- Adhere tile, stone or thin brick directly to PermaBase in exterior applications – saving time and money
- Durable substrate for direct-applied coating systems
- Meets UL classifications for one- and two-hour fire-rated assemblies
- Building code approved – one substrate that does the job of many



### Offers Best In Class Warranty

- 15-Year Limited Warranty: Exterior applications

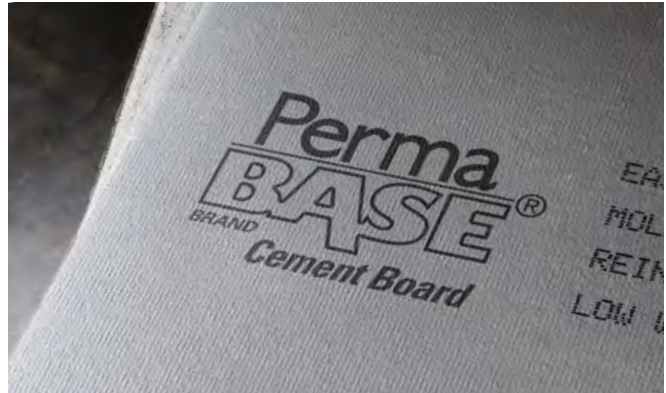

### Quality To The Core

1. Reinforced Edge
2. Fiberglass Mesh
3. Cementitious Core

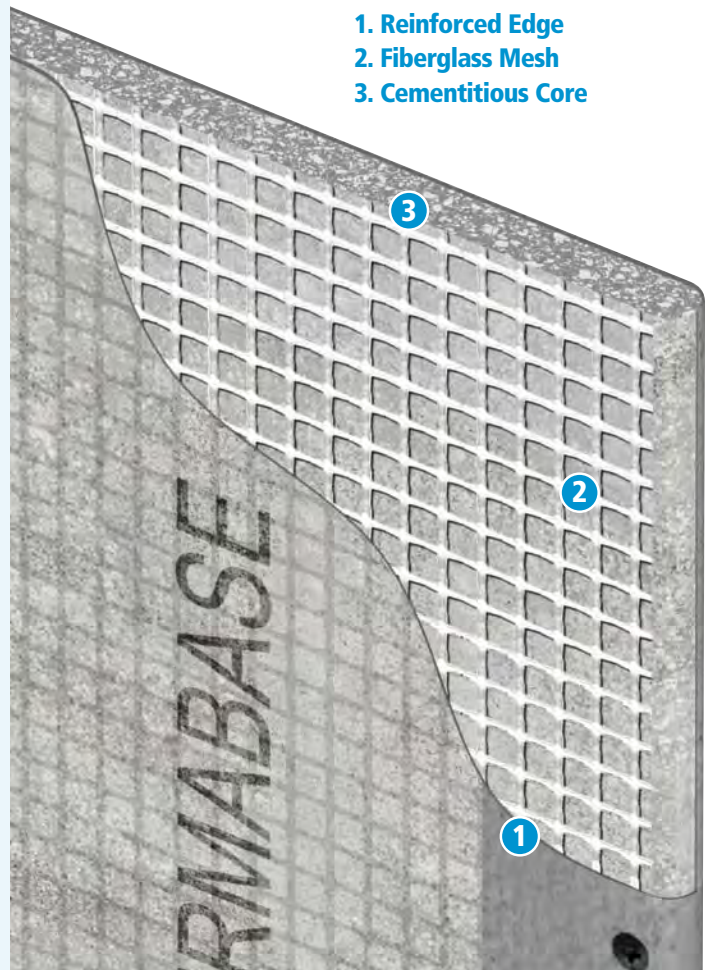

## Cement Board Masonry Veneer Wall System (CBMV)

For use in residential and low-rise commercial applications, CBMV offers a complete, engineered solution for installation of adhered veneers. It provides the ability to incorporate an effective water-management system for a variety of building exteriors with manufactured or natural stone and thin brick veneers.

### BENEFITS INCLUDE

- Engineered system that allows a faster installation while providing superior quality control (manufactured product that must comply with ASTM product specifications)
- Increased performance by utilizing modified adhesive mortars (designed for hanging materials) rather than type S&N mortars (developed for stacking materials)
- Extremely durable with increased resistance to impact and inclement weather
- Approved for use in ASTM 1780, and cement board is cited as an approved substrate for this system by the Masonry Veneer Manufacturers Association (MVMA): *Installation Guide and Detailing Options for Compliance with ASTM C1780*
- Easily allows for the inclusion of continuous installation into the assembly
- Appropriate for all climates, and resists the growth of mold and mildew

- Speed up your schedule – faster, easier and cleaner than traditional metal lath/scratch-coat method
- IBC/IRC compliant; meets ASTM C1325
- PermaBase® is approved as a substrate for direct applied finishes, tile, stone and thin brick in exterior applications, as outlined in UL Evaluation Report ER-22158
- PermaBase® is suitable for use in combustible and noncombustible construction under the IBC and IRC, as outlined in UL Evaluation Report ER-22158

### LIMITATIONS

- Sheathing selection and installation varies according to type of wall construction
- Code-approved water/air resistive barrier (WRB) must be installed to protect the cavity (type and placement will vary per local building codes and/or manufacturer's specifications, installation guidelines and warranties)

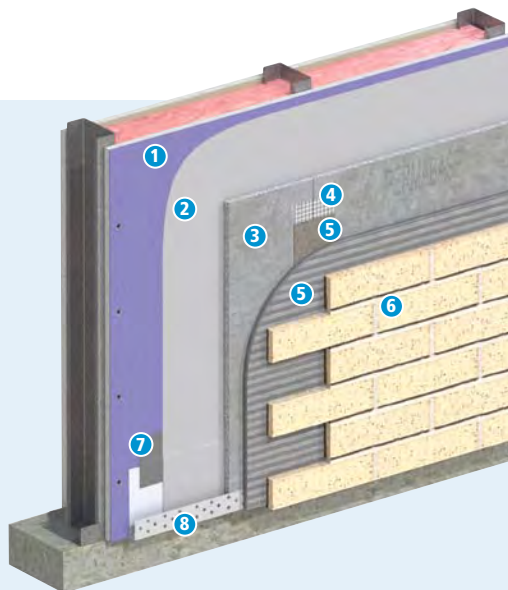

### Cement Board Masonry Veneer-Thin Brick

- |                              |                      |
|------------------------------|----------------------|
| 1. EXP® Sheathing            | 5. Mortar            |
| 2. Weather Resistant Barrier | 6. Thin Brick Veneer |
| 3. PermaBase® Cement Board   | 7. Flashing Tape     |
| 4. Mesh Tape                 | 8. Weep Screed       |

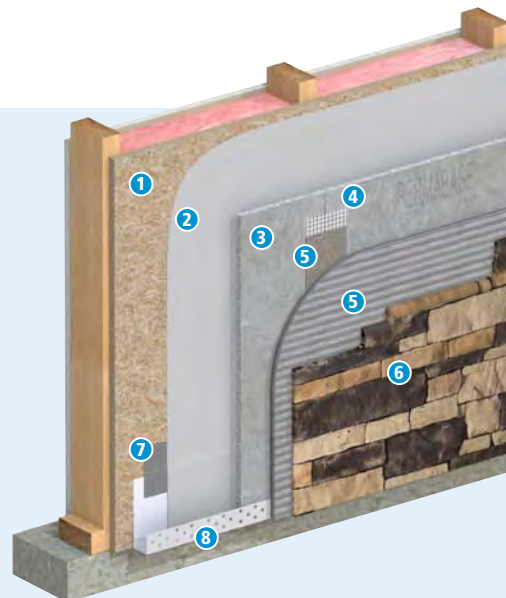

### Cement Board Masonry Veneer - Stone

- |                              |                      |
|------------------------------|----------------------|
| 1. Sheathing                 | 6. Thin Stone Veneer |
| 2. Weather Resistant Barrier | 7. Flashing Tape     |
| 3. PermaBase® Cement Board   | 8. Weep Screed       |
| 4. Mesh Tape                 |                      |
| 5. Mortar                    |                      |

## Cement Board Stucco Wall Systems (CBSS)

For use in residential and low-rise commercial applications, CBSS provides a drainage system to help prevent water from penetrating behind cladding in framed construction. It complies with ASTM D226, protecting approved sheathings/structural components and helping to evacuate incidental water.

### BENEFITS INCLUDE

- Appropriate for all climates and resists the growth of mold and mildew
- Extremely durable with increased resistance to impact and inclement weather
- Acrylic polymers provide more resistance to fading, cracking and peeling
- Engineered system that allows a faster installation while providing superior quality control (manufactured product that must comply with ASTM product specifications)
- Provides a 15-year exterior warranty – the industry's best

### LIMITATIONS

- Follow finish material manufacturer's instructions for proper installation
- Treat joints in PermaBase<sup>®</sup> with mesh tape and base coat
- Thin veneer construction can reveal planar irregularities in framing
- Minor cracking at joints may become visible in finished exterior surface
- Exterior finishes applied directly to PermaBase<sup>®</sup>: Reinforcing mesh must be embedded in base coat (consult exterior finish manufacturer for additional installation requirements)
- Conventional Portland cement plaster systems: Self-furring metal lath must be used over PermaBase<sup>®</sup> and fastened to studs
- Code-approved water/air resistive barrier (WRB) must first be installed to protect the cavity (type and placement will vary per local building codes and/or manufacturer's specifications, installation guidelines and warranties)

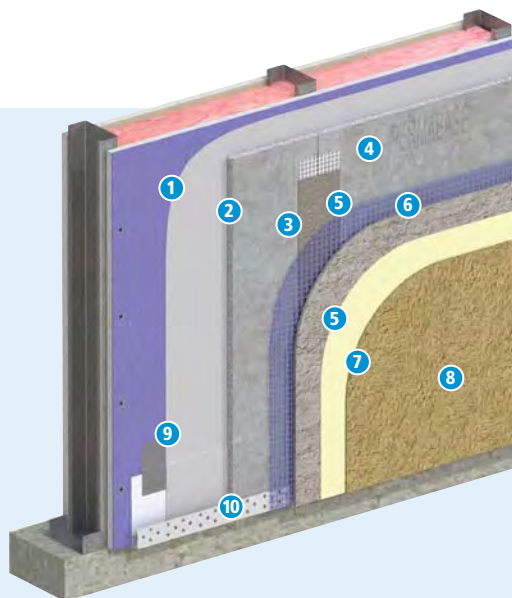

### Cement Board Stucco

- |  |                     |
|--|---------------------|
| 1. EXP <sup>®</sup> Sheathing          | 6. Reinforcing Mesh |
| 2. Weather Resistant Barrier           | 7. Primer           |
| 3. PermaBase <sup>®</sup> Cement Board | 8. Finish Coat      |
| 4. Mesh Tape                           | 9. Flashing Tape    |
| 5. Base Coat                           | 10. Weep Screed     |

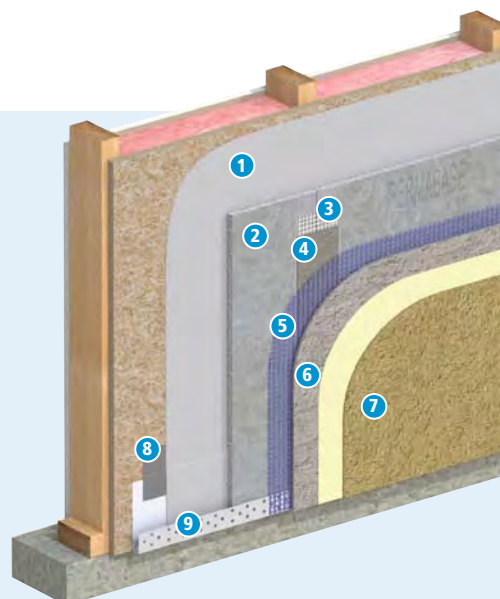

### Wood Board Stucco

- |  |                  |
|--|------------------|
| 1. Weather Resistant Barrier           | 6. Base Coat     |
| 2. PermaBase <sup>®</sup> Cement Board | 7. Finish Coat   |
| 3. Mesh Tape                           | 8. Flashing Tape |
| 4. Base Coat                           | 9. Weep Screed   |
| 5. Reinforcing Mesh                    |                  |

## Continuous Insulation

For use in residential and low-rise commercial applications, Continuous Insulation offers a complete, engineered solution for required structural performance. Including PermaBase® as a component in this system reinforces the building and provides the ability to incorporate an effective water-management system.

### NFPA 285 Approvals

PermaBase is approved for use in NFPA 285 wall assemblies. Approvals include the following finishes: stucco, manufactured stone, natural stone, thin brick, and calcium silicate stones. Assemblies include options for expanded polystyrene, extruded polystyrene, polyisocyanurate, and polyurethane insulations. For complete systems details, see UL Evaluation Report R22158.

### BENEFITS INCLUDE

- Engineered system that allows a faster installation while providing superior quality control (manufactured product that must comply with ASTM product specifications)
- Helps mitigate the loss of heat/air conditioning by insulating the studs (reduces thermal bridging)
- Helps eliminate air and moisture leakage
- Appropriate for all climates, resists the growth of mold and mildew, and offers fire protection
- Provides added dimensional stability
- Helps prevent the water/air resistive barrier (WRB) from being compromised as assembly components shift
- Provides a 15-year exterior warranty – the industry's best

### LIMITATIONS

- Sheathing selection and installation varies according to type of wall construction
- Code-approved water/air resistive barrier (WRB) must first be installed (type and placement will vary per local building codes and/or manufacturer's specifications, installation guidelines and warranties)

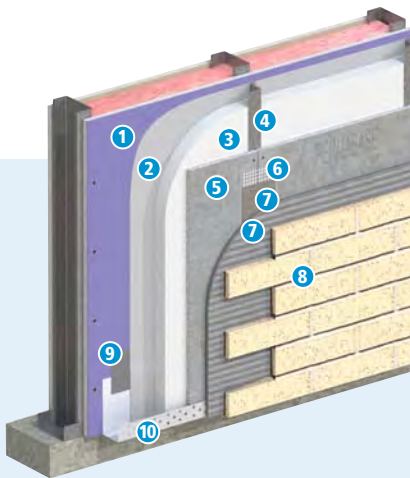

#### Continuous Insulation – Z Furring – Installation

- |                              |                      |
|------------------------------|----------------------|
| 1. EXP® Sheathing            | 6. Mesh Tape         |
| 2. Weather Resistant Barrier | 7. Mortar            |
| 3. Insulation                | 8. Thin Brick Veneer |
| 4. Z-Furring                 | 9. Flashing Tape     |
| 5. PermaBase® Cement Board   | 10. Weep Screed      |

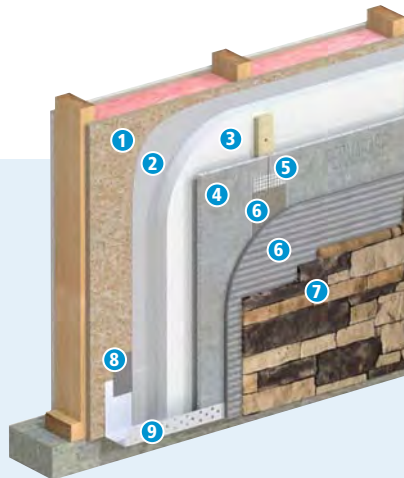

#### Continuous Insulation – Batten Strip

- |                              |                      |
|------------------------------|----------------------|
| 1. Sheathing                 | 6. Mortar            |
| 2. Weather Resistant Barrier | 7. Thin Stone Veneer |
| 3. Insulation                | 8. Flashing Tape     |
| 4. PermaBase® Cement Board   | 9. Weep Screed       |
| 5. Mesh Tape                 |                      |

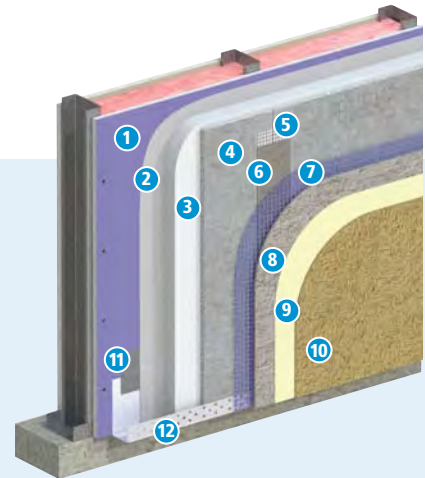

#### Continuous Insulation – Specialty Fastener

- |                              |                   |
|------------------------------|-------------------|
| 1. EXP® Sheathing            | 6. Base Coat      |
| 2. Weather Resistant Barrier | 7. Mesh           |
| 3. Insulation                | 8. Base Coat      |
| 4. PermaBase® Cement Board   | 9. Primer         |
| 5. Mesh Tape                 | 10. Finish Coat   |
|                              | 11. Flashing Tape |
|                              | 12. Weep Screed   |

This section of the PermaBase Construction Guide provides information on how to utilize PermaBase within both a CBMV System and a Continuous Insulation System. While some typical examples are shown (right) for reference purposes, the specifications and details on how to design and construct individual systems should be obtained from the adhering material or veneer manufacturer of the materials that are being used to complete the system. [For more information, go to permaBase.com/exterior](http://permaBase.com/exterior).

# Installation Guide

# Exterior Applications

## An ideal substrate for exterior applications, such as:

- Tile applications
- Stucco applications
- Cement board stucco
- Thin brick
- Adhered stone veneer
- Thin porcelain tile
- Ventilated rainscreen facade
- EIFS
- Continuous Insulation
- Outdoor kitchens/grills

### INSTALLATION

**General:** All framing should comply with local building code requirements and be designed to provide support with a maximum allowable deflection of L/360 under all intended live (including wind) and dead loads.

**Note:** Cut or score PermaBase® on rough side of panel.

**Control Joints:** For exterior installations, allow a maximum of 16 lineal feet between control joints. Consult finish manufacturer for other requirements. For exterior tile applications, control joints should be spaced a maximum of every 12'. A control joint must be installed but not limited to the following locations: where expansion joints occur in the framing or building (discontinue all cross furring members located behind joint); when boards abut dissimilar materials; where framing material changes; at changes of building shape or structural system; at each story separation. Place control joints at corners of window and door openings, or follow specifications of architect. Control joint cavity shall not be filled with coating or other materials.

### WALLS AND CEILINGS

**Wall Framing:** Studs should be spaced a maximum of 16" o.c. Edges/ends of PermaBase® parallel to framing should be continuously supported. Provide additional blocking when necessary to permit proper PermaBase® attachment. Do not install PermaBase® directly over protrusions from stud plane such as heavy brackets or fastener heads.

**Ceiling Framing:** The deflection of the complete ceiling assembly due to dead load (including insulation, PermaBase®, bonding material and facing material) should not exceed L/360. The dead load applied to the ceiling frame should not exceed 10 psf. Ceiling joist or furring channel should not exceed 16" o.c. (Edges of PermaBase® parallel to framing should be continuously supported.) Provide additional blocking when necessary to permit proper PermaBase® attachment.

**Water Barrier:** While PermaBase® is unaffected by moisture, a water/air resistive barrier (WRB) must be installed to protect the cavity. The type and specific placement or location of the water barrier will vary based on local building codes and/or manufacturers' warranties. Consult the WRB manufacturer's recommendations for specific installation guidelines.

**PermaBase® Cement Board:** Apply PermaBase® with ends and edges closely butted but not forced together. Stagger end joints in successive courses. Drive fasteners into field of cement board first, working toward ends and edges. Space fasteners maximum 8" o.c. into framing for walls, 6" o.c. into joists for ceilings with perimeter fasteners at least 3/8" and less than 5/8" from ends and edges.

**Joint Reinforcement:** Trowel bonding material to completely fill the tapered recessed board joints and gaps between each panel. On non-tapered joints, apply a 6" wide, approximately 1/16" thick coat of bonding material over entire joint. For all joints, immediately embed 4" alkali-resistant fiberglass mesh tape fully into applied bonding material and allow to cure. Same bonding material should be applied to corners, control joints, trims or other accessories. Feather bonding material over fasteners to fully conceal.



## PHYSICAL PROPERTIES

Property Method	Test	1/4"	7/16" PLUS	1/2"	5/8"
Water Absorption % By Weight/24 Hours	ASTM C 473	<8	<10	<8	<8
Flexural Strength (psi)	ASTM C 947	>1750	750	750	>1000
Fastener Holding (Wet and Dry, lbs.) (0.400" head diameter)	ASTM D 1037	>85	>90	>90	>90
Weight (psf)	ASTM C 473	1.8	2.1	2.1	3.65
Freeze/Thaw (Cycles)	ASTM C 666	100	100	100	100
Flame Spread / Smoke Developed	ASTM E 84	0/0	0/0	0/0	0/0
Compressive Strength (psi) (Indentation)	ASTM D 2394	N/A	N/A	1450	1250
Wind Load	ASTM E 330	N/A	30	40	40
Thermal "R"/k Value	Property of Material	0.2/2.7	0.28/2.7	0.37/2.7	0.47/2.7
Bending Radius (ft.)	Property of Material	N/A	5	5	5
Falling Ball Impact	ASTM D 1037	Pass	Pass	Pass	Pass
Linear Variation (Due to change in moisture content)	ASTM D 1037	<0.07%	0.05%	0.05%	0.05%
Fungus Resistance	ASTM G 21	No Growth	No Growth	No Growth	No Growth
Mold Growth On Surface	ASTM D 3273*	10	10	10	10
Shear Bond Strength (7 Days psi) Dry-Set Portland Cement Mortar	ANSI A 118.1	N/A	N/A	204	N/A
Shear Bond Strength (7 Days psi) Latex Portland Cement Mortar	ANSI A 118.4	N/A	N/A	241	N/A
Shear Bond Strength (7 Days psi) Organic Adhesives Type 1	ANSI A 136.1	N/A	N/A	159	N/A

\* When tested by an independent laboratory per ASTM D 3273 ("Standard Test Method for Resistance to Growth of Mold on the Surface of Interior Coatings in an Environmental Chamber"), PermaBase achieved a panel score of 10, the highest score possible, indicating no mold growth under the laboratory test conditions. The use of PermaBase in actual installations may not produce the same results as were achieved in controlled laboratory conditions. No material can be considered "mold proof," nor is it certain that any material will resist mold indefinitely.

## SIZES AND PACKAGING

Size: Thickness, Width And Length	# Of Pcs Per Unit
<b>PermaBase Cement Board</b>	
1/2" x 32" x 5' (12.7 mm x 813 mm x 1524 mm)	50*
1/2" x 32" x 8' (12.7 mm x 813 mm x 2438 mm)	50
1/2" x 36" x 4' (12.7 mm x 914 mm x 1219 mm)	50*
1/2" x 36" x 5' (12.7 mm x 914 mm x 1524 mm)	50
1/2" x 36" x 6' (12.7 mm x 914 mm x 1829 mm)	50*
1/2" x 36" x 8' (12.7 mm x 914 mm x 2438 mm)	30*
1/2" x 48" x 8' (12.7 mm x 1219 mm x 2438 mm)	35
5/8" x 48" x 8' (15.9 mm x 1219 mm x 2438 mm)	24
5/8" x 36" x 5' (15.9 mm x 914 mm x 1524 mm)	35
3/8" x 36" x 5' (9.5 mm x 914 mm x 1524 mm)	50*
3/8" x 48" x 8' (9.5 mm x 1219 mm x 2438 mm)	40*
3/4" x 48" x 8' (19.0 mm x 1219 mm x 2438 mm)	20
<b>PermaBase Underlayment</b>	
1/4" x 48" x 4' (7.9 mm x 1219 mm x 1219 mm)	60
1/4" x 36" x 5' (7.9 mm x 914 mm x 1524 mm)	60

\* Special Order

## Installation Accessories

For a seamless installation, we recommend PermaBase Tape and PermaBase Screws.



### Fasteners

PermaBase corrosion resistant screws or equivalent, 1-1/4" or 1-5/8" long, for use with wood framing. Type S-12 screws or equivalent, 1-1/4" or 1-5/8" long, for use with 20 gauge or heavier steel framing.

Galvanized roofing nails, 1-1/2" long with hot dipped galvanized coating for use with wood framing. Nails should meet Federal Specification #FF-N105B/type 2 style 20.

### Joint Reinforcement

PermaBase mesh tape must be used on all edges and cuts made to size. Use 2" wide polymer-coated (alkali resistant) mesh tape for interior applications and 4" wide polymer-coated (alkali resistant) mesh tape for exterior applications.

### Bonding Materials

Treat joint and set facing material, preferably with latex-Portland cement mortar or with dry-set (thin-set) mortar. All mortars should comply with ANSI A118.1, A118.4 or A118.15 standards. Type 1 organic adhesive meeting ANSI A-136.1 may be utilized for interior use only.

## LIMITED WARRANTY AND REMEDIES

Products manufactured and sold by National Gypsum Company are warranted by National Gypsum Company to its customers to be free from defects in materials and workmanship at the time of shipment. THIS EXPRESS WARRANTY IS THE ONLY WARRANTY APPLICABLE TO SUCH PRODUCTS, AND IS IN LIEU OF AND EXCLUDES ALL OTHER EXPRESS ORAL OR WRITTEN WARRANTIES AND ALL IMPLIED WARRANTIES, INCLUDING BUT NOT LIMITED TO THE IMPLIED WARRANTIES OF MERCHANTABILITY AND FITNESS FOR A PARTICULAR PURPOSE.

National Gypsum Company will not be liable for any incidental, indirect or consequential losses, damages or expenses. The customer's exclusive remedy for any type of claim or action for defective products will be limited to the replacement of the products (in the form originally shipped) or, at National Gypsum's option, to a payment or credit not greater than the original purchase price of the products.

### Mold And Mildew Resistance

PermaBase was designed to provide extra protection against mold and mildew. When tested by an independent laboratory, PermaBase received the highest possible ratings on ASTM G 21 and D 3273. The use of PermaBase in actual installations may not produce the same results as were achieved in controlled laboratory conditions. No material can be considered "mold-proof," nor is it

National Gypsum Company will not be liable for products claimed to be defective where the defect resulted from causes not within National Gypsum's control, or which arose or occurred after shipment, including but not limited to accidents, misuse, mishandling, improper installation, contamination or adulteration by other materials or goods, or abnormal conditions of temperature, moisture, dirt or corrosive matter.

Any claim that products sold by National Gypsum Company were defective or otherwise did not conform to the contract of sale is waived unless the customer submits it in writing to National Gypsum within thirty (30) days from the date the customer discovered or should have discovered the defect or non-conformance. No legal action or proceeding complaining of goods sold by National Gypsum may be brought by the customer more than one year after the date the customer discovered or should have discovered the defect or problem of which it complains.

certain that any material will resist mold or mildew indefinitely. When used in conjunction with good design, handling and construction practices, PermaBase can provide increased mold resistance. As with any building material, avoiding water exposure during handling, storage and installation, and after installation is complete, is the best way to avoid the formation of mold or mildew.

## CUSTOMER SERVICE SALES AREAS

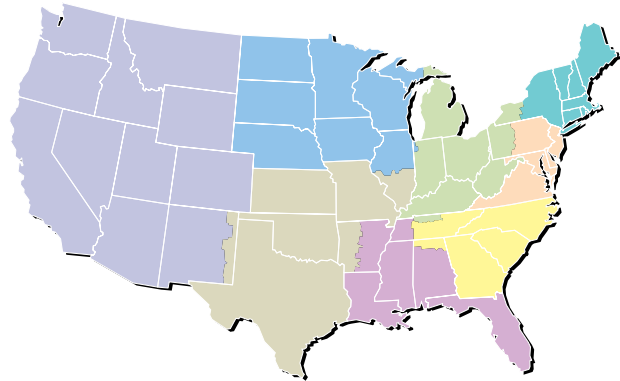

### Atlantic Area

Phone: (800) 237-9167  
Fax: (877) 252-0430

### Central Area

Phone: (800) 252-1065  
Fax: (866) 232-0440

### Gulf Area

Phone: (800) 343-4893  
Fax: (866) 482-8940

### Midwest Area

Phone: (800) 323-1447  
Fax: (866) 692-8590

### Northeast Area

Phone: (800) 253-3161  
Fax: (866) 632-1480

### Southeast Area

Phone: (800) 548-9394  
Fax: (866) 732-1990

### Southwest Area

Phone: (800) 548-9396  
Fax: (866) 792-7520

### Western Area

Phone: (800) 824-4227  
Fax: (800) 438-6266

### National Accounts

Phone: (800) 440-1230  
Fax: (866) 622-3590

### Manufactured Housing

Phone: (800) 455-3185  
Fax: (800) 639-1714



**Perma**  
**BASE**<sup>®</sup>  
BRAND  
**Cement Board**

[permabase.info](http://permabase.info)



PRODUCT  
CERTIFIED FOR  
LOW CHEMICAL  
EMISSIONS:  
UL.COM/GG  
UL 2818

### Corporate Headquarters

National Gypsum Company  
2001 Rexford Road  
Charlotte, NC 28211  
Phone: (704) 365-7300  
Web: [nationalgypsum.com](http://nationalgypsum.com)

### Technical Information

Phone: (800) NATIONAL  
(800) 628-4662  
Fax: (800) FAX-NGC1  
(800) 329-6421

**National**  
**Gypsum**<sup>®</sup>

## UltraBond Veneer Mortar Adhesive

UltraBond is a premium, polymer-fortified, adhesive mortar for the installation of thin brick, synthetic and natural stone products, ceramic tile and quarry tile. UltraBond Veneer Mortar Adhesive mixes easily with water to a creamy consistency and is formulated with high initial grab and shear resistance.

### Coverage per bag

#### Vertical Applications

1/4" x 3/8" (6 mm x 9 mm) Notched Trowel:  
60–70 Ft<sup>2</sup>, 5.6–6.5 M<sup>2</sup>

1/2" x 1/2" (12 mm x 12 mm) Notched Trowel:  
40–45 Ft<sup>2</sup>, 3.7–4.2 M<sup>2</sup>

Adhered Masonry Veneer Application Method:  
30–33 Ft<sup>2</sup>, 2.8–3.1 M<sup>2</sup>

Coverage may vary depending upon application technique and surface conditions.

### Packaging/Shelf Life/Storage

Packaging: 50 lb (22.7 kg) bag

Shelf Life: 2 years

Storage: Protect from moisture and high humidity.

### Technical Data

#### Compression (ASTM C270)

24 hours - 500 psi

7 day - 2700 psi

28 day - 3350 psi

#### Tensile (ANSI A118) Glazed/Mosaic

7 day - 315 psi / 305 psi

28 day - 500 psi / 290 psi

#### Shear Bond (ANSI A118.15) Glazed/Mosaic

7 day dry - 475 psi / 460 psi

7 day wet - 390 psi / 400 psi

28 day dry - 625 psi / 450 psi

#### Sag Resistance

(ISO 13007 24.2)

Quarry Tile - 0.0

Large Scale Tile - .485

Full Scale Stone - 0.0

**Hazard:** Considered hazardous by the 2012 OSHA Hazard Communication Standard (29 CFR 1910.1200)

**VOC:** Less than 50 g/L.

### Features & Benefits

- Non-Sag
- Strong adhesion with Thin Brick and synthetic stone products
- Class leading shear bond strength
- Mixes easily with good open time
- Vapor Permeable - resists blistering and allows trapped water vapors to pass
- Freeze stable in dry form

Application Temperature: 40°-110°F (5°-43°C) • Working Time: 1 hr • Dry Time: 12 hrs

at room temperature, working and drying time will vary with temperature and humidity

### Surface Preparation & Mixing

**Job Conditions** - Air and substrate temperature for application of UltraBond must be 40°F (5°C) or higher and must remain 40°F (5°C) or higher for a minimum of 24 hours. Provide temporary protection to protect the wall system from damage until permanent flashings, caps and sealants are installed. Store materials within prescribed temperature limits and out of direct sunlight. Working and drying times are based upon normal room temperature conditions and will vary with temperature and humidity.

Installer must verify that deflection under all live, dead and impact loads of substrates does not exceed industry standards of L/600 for AMSMV units or stone installations where L=span length. For exterior vertical installations over framed construction, the substrate deflection under all live, dead and impact loads, including concentrated loads, must not exceed L/600 where L=span length.

**Preparation** - The substrate must be approved by Master Wall Inc<sup>®</sup>, clean, dry, structurally sound and free of efflorescence, oil, grease, form release agents and curing compounds or anything that would affect bond. Painted surfaces are not acceptable and must be removed.

**Mixing** - Add 5 to 6 quarts (4.7-5.7 L) of potable water to a clean plastic pail. Add the UltraBond slowly while stirring using a heavy-duty 1/2" (12.7 mm) drill at 400 - 500 rpm and a heavy-duty mixer. Mix thoroughly to a homogeneous but stiff consistency. Let the mixture stand for 5 to 10 minutes and then remix without adding any more water or powder. During use, stir occasionally to keep mix fluffy. DO NOT temper with water. Excessive stirring may cause faster setting and reduced working time. Do not add accelerators or retarders to the UltraBond mixture.

## UltraBond Veneer Mortar Adhesive

### Health & Safety

#### WARNING!

Causes eye damage and skin burns if not used properly.

#### Precautionary Statement

Wear protective gloves/protective clothing/eye protection/face protection. Wash face, hands and any exposed skin thoroughly after handling. Do not eat, drink or smoke when using this product. Contaminated work clothing must not be allowed out of the workplace. Do not breathe dust/fume/gas/mist/vapors/spray. Use only outdoors or in a well-ventilated area.

#### FIRST AID MEASURES

**Eye Contact:** Rinse cautiously with water for several minutes. Remove contact lenses, if present and easy to do. Continue rinsing. Get immediate medical attention.

**Skin Contact:** Take off immediately all contaminated clothing. Rinse skin with water/shower. Wash contaminated clothing before reuse. If skin irritation or rash occurs get medical attention.

**Inhalation:** If inhaled, remove to fresh air. If not breathing, give artificial respiration or give oxygen by trained personnel. Seek immediate medical attention.

**Ingestion:** Call a POISON CENTER or doctor if you feel unwell. Rinse mouth. Do NOT induce vomiting.

Store locked up. Dispose of contents/container in accordance with Local, State, Federal and Provincial regulation.

**Spills:** Prevent further leakage or spillage if safe to do so. Clean up powdered material with vacuum equipped with HEPA filter.

**Disposal:** Dispose of in accordance with local, state or federal regulations.

**Warning:** KEEP CONTAINER CLOSED WHEN NOT IN USE. KEEP OUT OF THE REACH OF CHILDREN. NOT FOR INTERNAL CONSUMPTION. FOR INDUSTRIAL USE ONLY. Consult the Safety Data Sheet (SDS) in the Products section at masterwall.com for further health and safety information.

#### LIMITED WARRANTY

This product is subject to a written limited material or system warranty. Obtain a warranty from the Tech Support tab of our website. Refer to Specifications for more complete information on proper use and handling of this product.

### Approved Substrates

Stucco (Scratch or Brown)

Mortar Parge Coat

Master Wall Base Coats

Durock®

PermaBase®

Util-A-Crete®

ProTEC®, ProGUARD®

Concrete

Brick

Masonry

Metal Lath

Adheres to Rollershield

Others approved in writing

### Application Procedure

Prior to installation, ensure back of veneer units are clean of dust, laitance, loose concrete crumbs and any excess film that could impede bond. Porous and excessively dry substrates such as cement board, masonry or stucco may need to be wetted to avoid excessive absorption, allow to dry to the touch. Verify wetting requirements with the veneer manufacturer.

For adhered stone, thin brick and manufactured stone masonry veneers installations, use a gauging trowel to key a thin coat of UltraBond Veneer Mortar Adhesive to cover entire back of the veneer units. Spread additional mortar onto the back of the skim coated veneer sufficient to completely fill the space between the veneer and the substrate when compressed against the substrate. Press the mortar covered back of the veneer against the substrate at the desired final position. Slide the unit roughly 1 -1.5" (25-38mm) diagonally from the desired final position and back into the desired position while maintaining even pressure. This should be done in such a manner as to squeeze the mortar to fill the entire space between the veneer unit and the substrate, allowing excess mortar to extrude on all sides around the veneer unit. Clean excess extruded mortar with trowel and spread onto the next veneer unit to be installed.

Alternate method for thin brick, tile, calcium silicate unit and stone installations: key UltraBond Veneer Mortar Adhesive into the substrate thoroughly. Then, comb on additional mortar with the notched side, use 1/4" x 3/8" (6 mm x 9 mm), 1/2" x 1/2" (12 mm x 12 mm) loop or notch trowel. Back butter all thin brick, veneer units 8" x 8" (200 mm x 200 mm), 3/4" (19 mm) loop trowel or larger to provide full bedding of the veneer. Place veneer into the mortar and adjust to desired position. Clean any excess mortar on sides of stone or tile veneer.

Note: Use proper sized notched trowel to ensure full bedding of the stone veneer. Spread only enough mortar for maximum coverage with tile within 15–20 minutes. Trowel notch size determined by contractor, size of veneer and job-site coverage. Adjust as necessary. Check mortar for complete coverage by periodically removing veneer unit and inspecting the transfer onto substrate and back of the stone veneer. The size and weight of the veneer will vary. Due to job site conditions and differences in finish material types; ledger boards, shims, wedges or spacers may be required to maintain finish levels and heights.

Grouting/Pointing (if required) - When required, point installation after a minimum of 24 hours curing time at 70°F (21°C). With an approved premium grout or mortar.

Clean Up—Tools and equipment can be cleaned with soapy water while the UltraBond is still wet.

WARNING, THIS PRODUCT CONTAINS SILICA

If sanding or scraping are performed, ventilate work area and/or use a NIOSH/MSHA-approved respirator in accordance with our Safety Data Sheet.

Product description information and basic uses etc.



Information contained in this product data sheet conforms to the standard detail recommendations and specifications for the installation of Master Wall Inc.® products and is presented in good faith. Master Wall Inc.® assumes no liability, expressed or implied as to the architecture, engineering, or workmanship of any project. This information may be concurrent with, or superseded by other applicable documents, such as specifications and details. Contact Master Wall Inc.® for the most current product information. ©2020 Master Wall Inc.®

masterwall.com

PO Box 397 • Fortson • GA • 31808 • 800-755-0825

## CIFS® Brick Mortar

Master Wall Inc.® CIFS® Brick Mortar is a polymer modified mortar finish that is used to create realistic, durable, color consistent and water resistant mortar joints in CIFS® Brick applications.

### Coverage per package

160-200 sf (14.8-18.6 sm)

Coverage may vary depending upon application technique and surface conditions.

### Batch Mixing Recommendations

#### 10# (4.5 kg) Batch

0.6-0.8 qt (.56-.76 L) water  
 32-40 sf (3-3.7 sm)

#### 20# (9 kg) Batch

1.2-1.6 qt (1.1-1.5 L) water  
 64-80 sf (6-7.4 sm)

#### 25# (11.3 kg) Batch

1.5-2 qt (1.4-1.9 L) water  
 80-100 sf (7.5-9.25 sm)

*Consistent mixing of batches is necessary for color consistency in the finished product!*

### Packaging/Shelf Life/Storage

Packaging: 50 lb (22.7 kg) bag

Shelf Life: 1 year

Storage: Protect from extreme heat (90°F (32°C), moisture and direct sunlight.

### Technical Data

**Properties:** Proprietary dry mix mortar.

**Hazard:** This chemical is considered hazardous according to the OSHA Hazard Communication Standard 2012 (29 CFR 1910.1200).

**VOC:** Less than 50 g/L.

### Features & Benefits

- Recreates the look of true mortar
- Polymer modified for durability
- Available in 4 colors
- Interior or exterior

Application Temperature: 40°-110°F (5°-43°C) • Working Time: 1 hr • Dry Time: 12 hrs

at room temperature, working and drying time will vary with temperature and humidity

### Surface Preparation

Timing and weather consistency is extremely important for accurate mortar color cure. Take the time to ensure good weather during application and seek training for the application process. This is a naturally curing product and variations are to be expected as it is in face brick installations.

Apply when air and substrate temperatures are between 40°F (4°C) and 100°F (38°C) within 24 hours of application and 72 hours thereafter. For applications outside this range of temperatures, contact Master Wall Inc.® Technical Services.

Surfaces must be dry and clean of dust and foreign materials, e.g., oil, grease and dirt. Thoroughly brush or vacuum surface and grout joints to insure that loose dust and dirt particles are removed. The surface must be frost-free.

### CIFS® Brick Mortar Colors

Light Buff CIFS® Brick Mortar

Light Smoke CIFS® Brick Mortar

Mist CIFS® Brick Mortar

Light Pewter CIFS® Brick Mortar

## CIFS® Brick Mortar

### Health & Safety

#### WARNING!

Causes severe skin burns and eye damage.

#### Precautionary Statement

Wash hands thoroughly after handling. Wear protective gloves/protective clothing/eye protection/face protection.

#### FIRST AID MEASURES

General Advice: Immediate medical attention is required. Show this safety data sheet to the doctor in attendance.

Eye Contact: Rinse immediately with plenty of water, also under the eyelids, for at least 15 minutes. Keep eye wide open while rinsing. Remove contact lenses, if present, after the first 5 minutes, then continue rinsing. Do not rub affected area. Immediate medical attention is required.

Skin Contact: Wash off immediately with soap and plenty of water for at least 15 minutes. May cause an allergic skin reaction. Immediate medical attention is required.

Inhalation: Remove to fresh air. Get medical attention immediately if symptoms occur.

Ingestion: Rinse mouth immediately and drink plenty of water. Do NOT induce vomiting.

Spills: Pick up and transfer to properly labeled containers.

Disposal: Dispose of in accordance with local, state or federal regulations.

Warning: KEEP CONTAINER CLOSED WHEN NOT IN USE. KEEP OUT OF THE REACH OF CHILDREN. NOT FOR INTERNAL CONSUMPTION. FOR INDUSTRIAL USE ONLY. Consult the Safety Data Sheet (SDS) in the Products section at [masterwall.com](http://masterwall.com) for further health and safety information.

#### LIMITED WARRANTY

This product is subject to a written limited material or system warranty. Obtain a warranty from the Tech Support tab of our website. Refer to Specifications for more complete information on proper use and handling of this product.

### Application Procedure

#### Prior to Application

CIFS® Brick Taratex Finish must be firmly set.

Mortar joint area must be clean, dry and free of excess finish materials, efflorescence or other products that will affect bond.

#### Mixing

Mix in small batches using the **same techniques and amount of materials**. A maximum small batch of 25 lb (11.3 kg) CIFS® Brick Mortar is recommended.

Use clean, cool, potable water, clean tools and mixing containers.

1. Pour half the amount of water needed into the clean mixing container.
2. Add CIFS® Brick Mortar to the liquid and mix to a creamy consistency.
3. Add more water as needed, up to the maximum recommended amount.
4. If using a mechanical mixer, do not exceed 150 rpm and avoid whipping air into mix which will reduce the strength of the mortar.
5. Let stand 10 minutes to give all ingredients time to slake. Remix and use.
6. Do not retemper with liquid or powder after this point. Once the CIFS® Brick Mortar has become too stiff to work, it must be discarded and a new batch made.
7. Always mix batches consistently with the same amount of material and water. Inconsistent batching will cause color variations.

#### Application

1. Place the CIFS® Brick Mortar Mixture into a grout bag or mortar gun. Cut opening to the width of the stencil joint size.
2. Squeeze into the mortar areas of the stencil taking care to completely fill the opening with a slight crown in the middle.
3. Let firm set thumbprint hard, then tool with the brick joint tool.
4. Wait approximately 30 minutes and remove any remaining excess with a brick pointing tool at a 90° angle to the surface to remove large pieces and a dry brush for small pieces, using light pressure while the mortar is still soft.
5. Protect from weather and adverse conditions for 72 hours before putting into service.

#### Cautions and Limitations

- Mixing, application and weather conditions are extremely important during the application to avoid efflorescence and color variations. Mix consistently and apply product corner to corner rather than in a phased application to help avoid color variations. Seek manufacturer assistance.
- Slope all exterior surfaces 1:2 minimum to shed water.
- Application in direct sunlight may affect aesthetics if the CIFS® Brick Mortar dries too quickly. Avoid direct sunlight.
- When cleaning do not use harsh or abrasive cleaners. Wash gently using a soap and water solution followed by a warm water rinse.
- Efflorescence, a white crystalline powder, can naturally occur with any Portland cement product. Use industry accepted cleaning procedure to remove any efflorescence.
- Color variations in the mortar should be expected, While color consistency is manufactured into the dry product, field application consistency can lead to varied results and is not guaranteed.

#### Clean Up

Tools and equipment can be cleaned with soapy water while the CIFS® Brick Mortar is still wet.

Information contained in this product data sheet conforms to the standard detail recommendations and specifications for the installation of Master Wall Inc.® products and is presented in good faith. Master Wall Inc.® assumes no liability, expressed or implied as to the architecture, engineering, or workmanship of any project. This information may be concurrent with, or superseded by other applicable documents, such as specifications and details. Contact Master Wall Inc.® for the most current product information. ©2020 Master Wall Inc.®



[masterwall.com](http://masterwall.com)

PO Box 397 • Fortson • GA • 31808 • 800-755-0825



# Master Wall Inc.®

*Building a Culture of Excellence*

## Master Wall® Light Masonry (LiMa) Program Limited Warranty

LiMa Assemblies LiMaW105, LiMaW205, LiMaM105, LiMaC105: 5 years  
LiMa Assemblies LiMaW110, LiMaW210, LiMai310TV, LiMai410CB, LiMai510CB: 10 years  
LiMa Assemblies LiMaW120, LiMaM120, LiMaM220, LiMaM320, LiMaM420: 20 years  
LiMa Assemblies LiMaC130, LiMaC230: 30 years

Master Wall Inc.® warrants the properly designed and installed Master Wall Inc.® materials for the term noted above from the date of installation over the listed, approved Light Masonry (LiMa) assemblies. Subject to the conditions and limitations stated below, Master Wall Inc.® warrants that the products listed on this document will be free from manufacturing defects and will not break down or deteriorate under normal usage for term stated above from the date of purchase when installed in accordance with the written specifications of Master Wall Inc.® and industry standard guidelines. For this limited warranty to apply, the applications that comprise the installation must be performed with the products listed in this document for each application (LiMa Assemblies). Please refer to individual product data sheets for specific guidelines.

Substrate deflection under all live, dead and impact loads, including concentrated loads, must not exceed  $L/600$  where  $L$ =span length. Applications must not exceed 30 ft (9.1 m) in height or 25,000 ft<sup>2</sup> (2,250 m<sup>2</sup>) in area. Installations must conform to all applicable building codes including the International Building Code (IBC) and International Residential Code (IRC) requirements.

### DISCLAIMER

THIS LIMITED WARRANTY IS GIVEN IN LIEU OF ANY OTHER WARRANTY, EXPRESS OR IMPLIED. THERE ARE NO WARRANTIES, EXPRESS OR IMPLIED, INCLUDING WARRANTIES BASED ON SAMPLES OR ORAL STATEMENTS, WHICH EXTEND BEYOND THE DESCRIPTION ON THE FACE OF THIS DOCUMENT. IMPLIED WARRANTIES OF MERCHANTABILITY AND OF FITNESS FOR A PARTICULAR PURPOSE ARE EXCLUDED.

### EXCLUSIONS

Master Wall Inc.® is not responsible for workmanship not in accordance with the instructions of Master Wall Inc. and industry standard guidelines. Cracking due to structural movement, excessive deflection or other failure in the substrate is also not covered. Master Wall Inc.® IS NOT LIABLE FOR ANY INCIDENTAL DAMAGES OR CONSEQUENTIAL DAMAGES, INCLUDING LOSSES DUE TO DELAYS, INCURRED BY THE PURCHASER OR ANY OTHER PARTY.

### NO ASSIGNMENT

This limited warranty is not transferable or assignable.



# Master Wall Inc.<sup>®</sup>

***Building a Culture of Excellence***

## EXCLUSIVE REMEDY

The sole and exclusive remedy for a breach of this limited warranty is replacement of only the specific portion of the installation that is proven to be defective\*. Master Wall Inc.<sup>®</sup> will pay for replacement of its own products and replacement of finishing materials, as well as for labor for the replacement installation, but Master Wall Inc. will not pay more, calculated on a square-foot (square-meter) basis, for the replacement than the original purchase price of the portion being replaced. Master Wall Inc.<sup>®</sup> will not pay for replacement of any portion of the installation that is not proven to be defective.

In the event that the sole and exclusive remedy described above fails of its essential purpose, the liability of Master Wall Inc.<sup>®</sup> is limited to the monetary value, on a square-foot (square-meter) basis, of the original purchase price of the portion being replaced.

\* NOTE: Efflorescence is a normal condition of Portland cement mortars and is not a defective condition.

This warranty becomes effective only when all bills for the components of the system have been paid.

Except as stated, Master Wall, Inc.<sup>®</sup>, expressly disclaims any warranty of merchantability or fitness for a particular purpose. The above remedies are to be deemed exclusive.

Project:

Applicator:

Warranty Date:

This is not the final warranty. For a valid warranty click on the support tab at [masterwall.com](http://masterwall.com) and request a warranty. Warranties are not valid until issued.



# System Detail

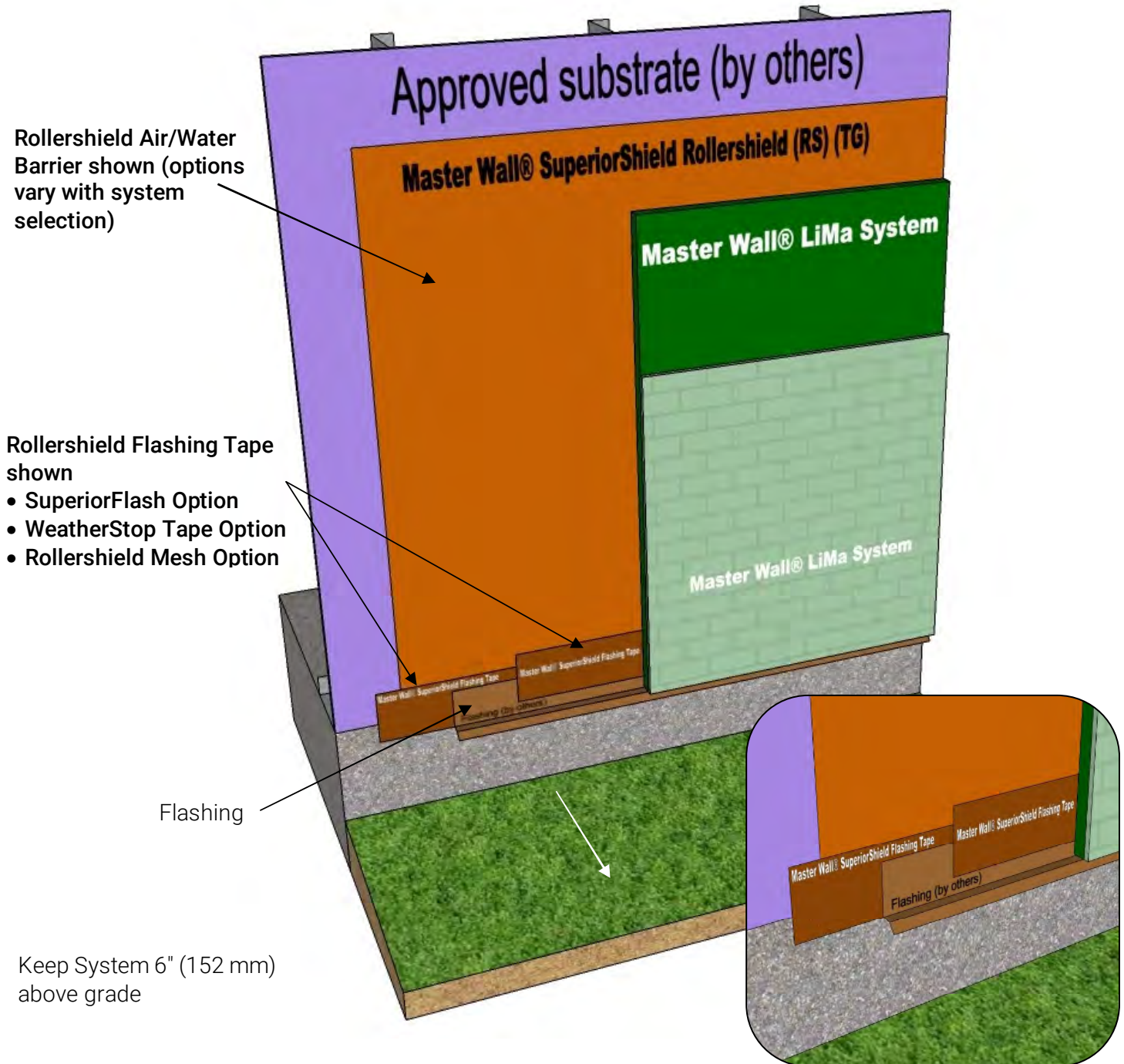

## ***LiMa D-01Detail @ Grade***

These drawings relay the conceptual conditions of Master Wall® Systems and are not the construction drawings. Ultimately the design and detailing of an entire wall system is the responsibility of a professional. These details will guide the design professional in the use of Master Wall® Products. Master Wall disclaims design, warranty or construction intent or responsibility. **Bold or Trade Name = Master Wall® Product.**

# System Detail

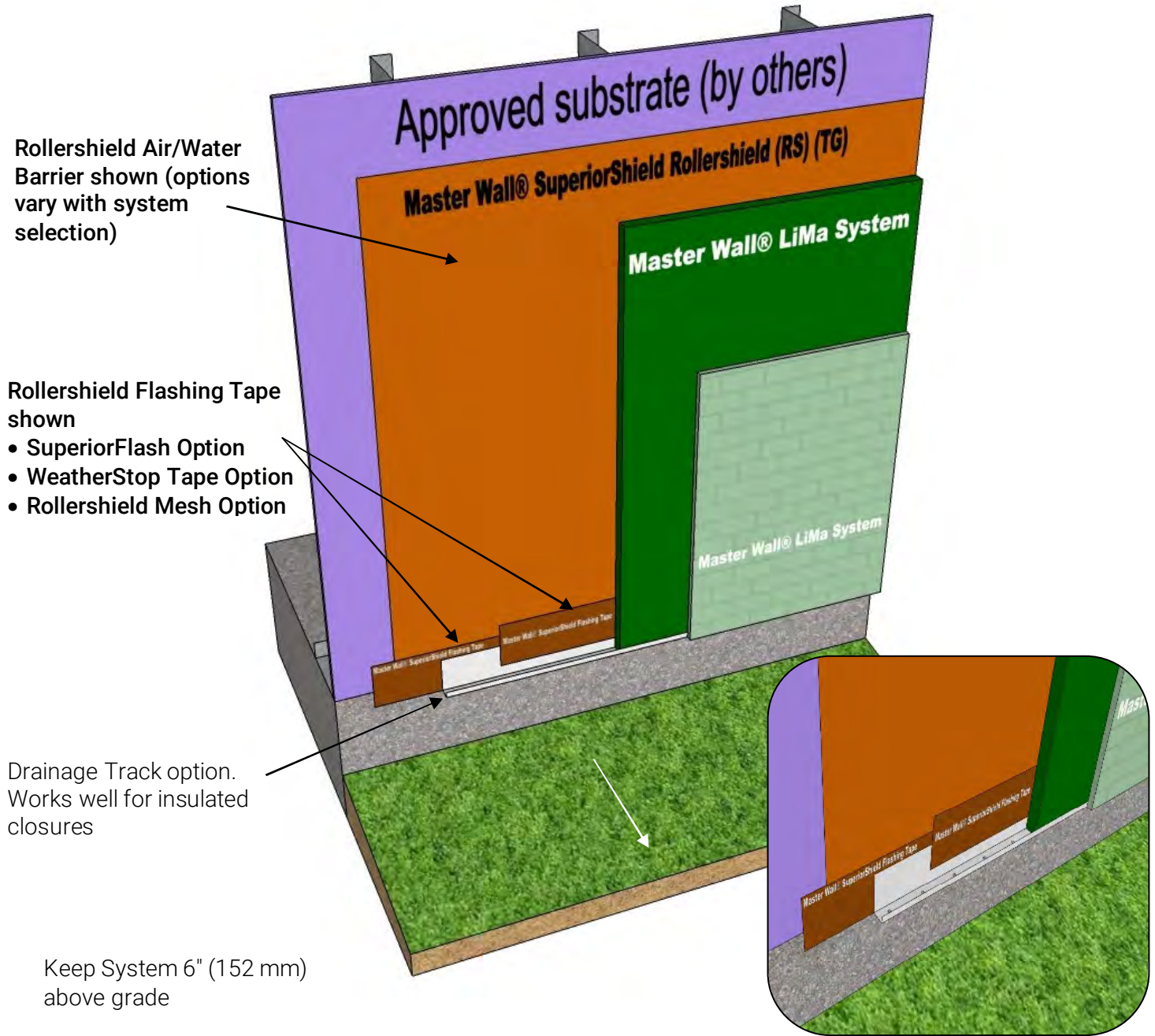

## ***LiMa D-02 Detail @ Grade***

These drawings relay the conceptual conditions of Master Wall® Systems and are not the construction drawings. Ultimately the design and detailing of an entire wall system is the responsibility of a professional. These details will guide the design professional in the use of Master Wall® Products. Master Wall disclaims design, warranty or construction intent or responsibility. **Bold or Trade Name = Master Wall® Product.** ©2020 Master Wall Inc.®

# System Detail

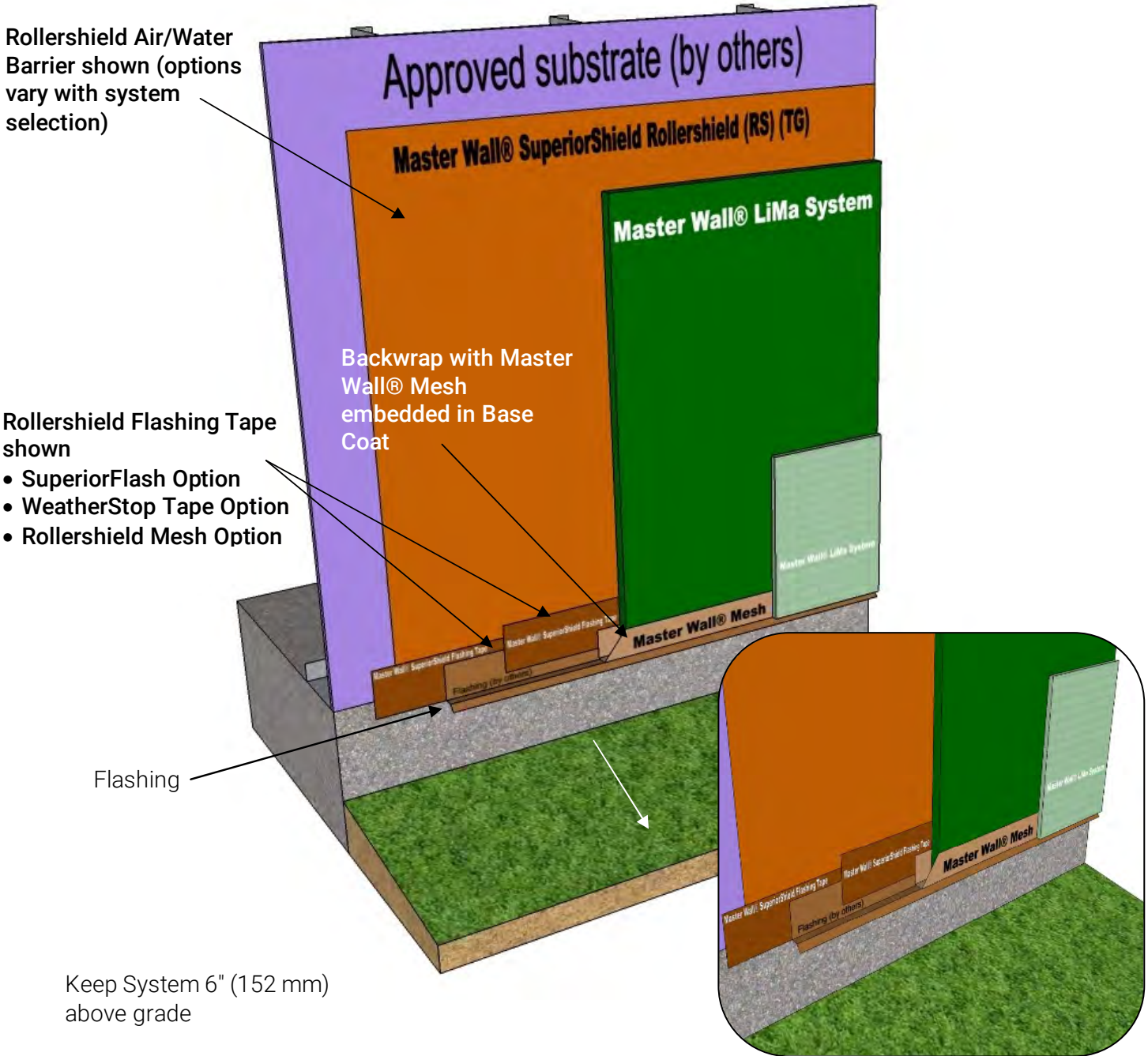

## ***LiMa D-03 Detail @ Grade***

These drawings relay the conceptual conditions of Master Wall® Systems and are not the construction drawings. Ultimately the design and detailing of an entire wall system is the responsibility of a professional. These details will guide the design professional in the use of Master Wall® Products. Master Wall disclaims design, warranty or construction intent or responsibility. **Bold or Trade Name = Master Wall® Product.** ©2020 Master Wall Inc.®

## System Detail

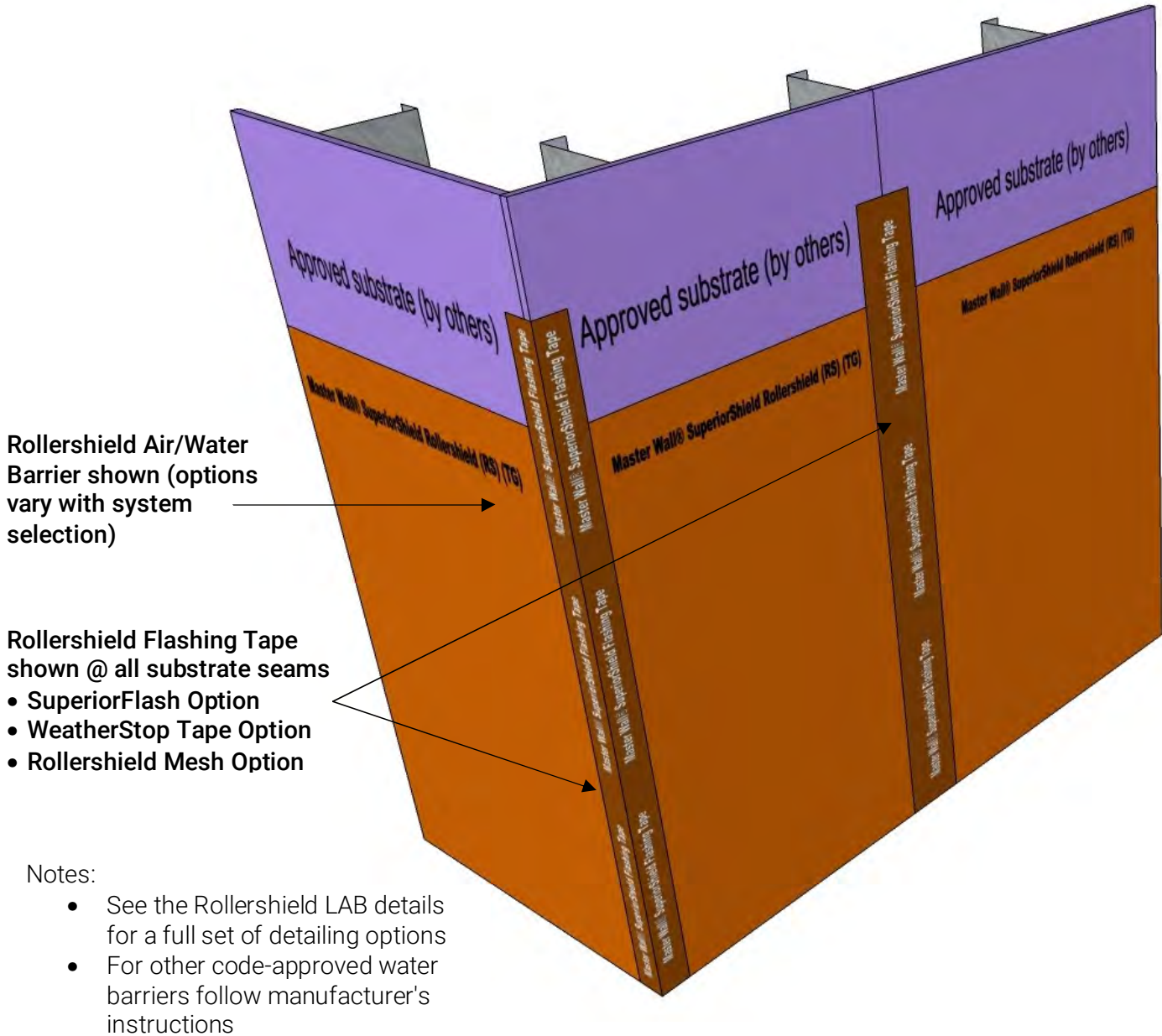

### ***LiMa D-04 Rollershield LAB Seam Details***

These drawings relay the conceptual conditions of Master Wall® Systems and are not the construction drawings. Ultimately the design and detailing of an entire wall system is the responsibility of a professional. These details will guide the design professional in the use of Master Wall® Products. Master Wall disclaims design, warranty or construction intent or responsibility. **Bold or Trade Name = Master Wall® Product.**

# System Detail

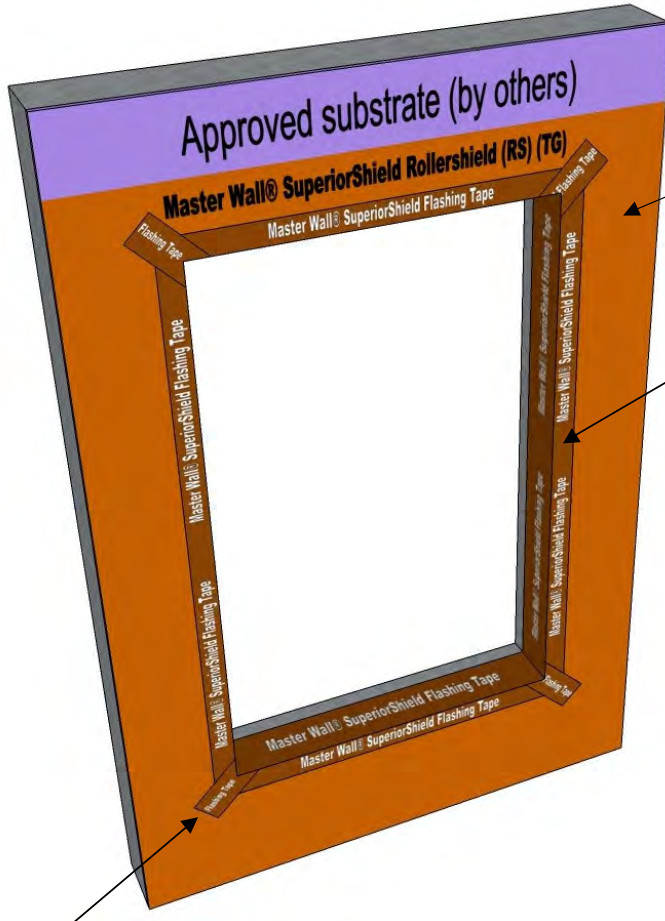

Rollershield Air/Water Barrier shown (options vary with system selection)

Rollershield Flashing Tape shown @ all substrate seams and turned into window opening at least the depth of the window unit

- SuperiorFlash Option
- WeatherStop Tape Option
- Rollershield Mesh Option

Rollershield Flashing Tape shown adhered over flashing

Window Head Flashing



Flanged Window Shown - Install per manufacturer's requirements

Diagonal Rollershield Flashing Tape shown

- SuperiorFlash Option
- WeatherStop Tape Option
- Rollershield Mesh Option

Notes:

- See the Rollershield LAB details for a full set of detailing options
- For other code-approved water barriers follow manufacturer's instructions

## ***LiMa D-05 Window Opening***

These drawings relay the conceptual conditions of Master Wall® Systems and are not the construction drawings. Ultimately the design and detailing of an entire wall system is the responsibility of a professional. These details will guide the design professional in the use of Master Wall® Products. Master Wall disclaims design, warranty or construction intent or responsibility. **Bold or Trade Name = Master Wall® Product.**

## System Detail

Rollershield Air/Water Barrier shown  
(options vary with system selection)

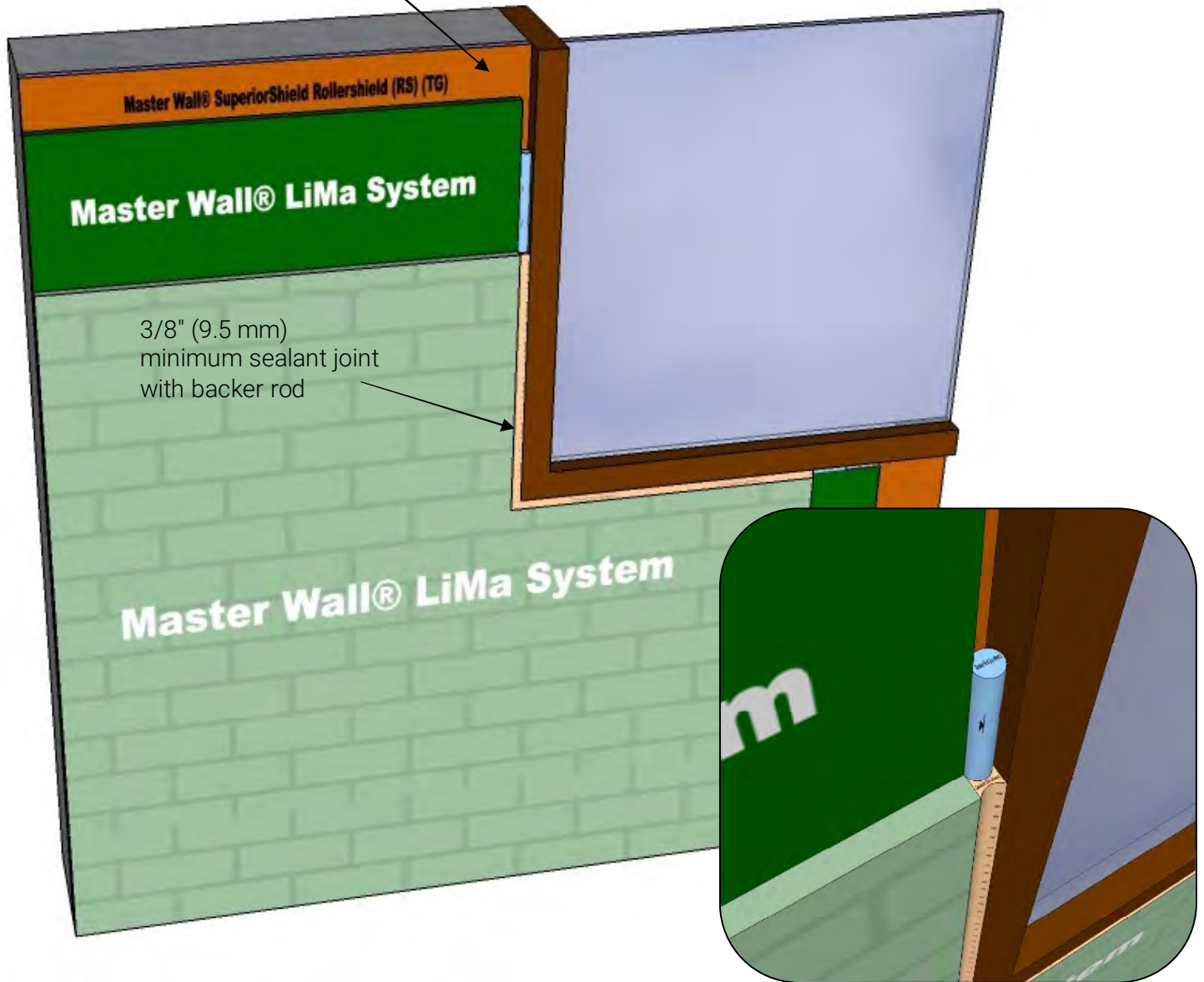

### ***LiMa D-06 LiMa to Window Detail***

These drawings relay the conceptual conditions of Master Wall® Systems and are not the construction drawings. Ultimately the design and detailing of an entire wall system is the responsibility of a professional. These details will guide the design professional in the use of Master Wall® Products. Master Wall disclaims design, warranty or construction intent or responsibility. **Bold or Trade Name = Master Wall® Product.** ©2020 Master Wall Inc.®

## System Detail

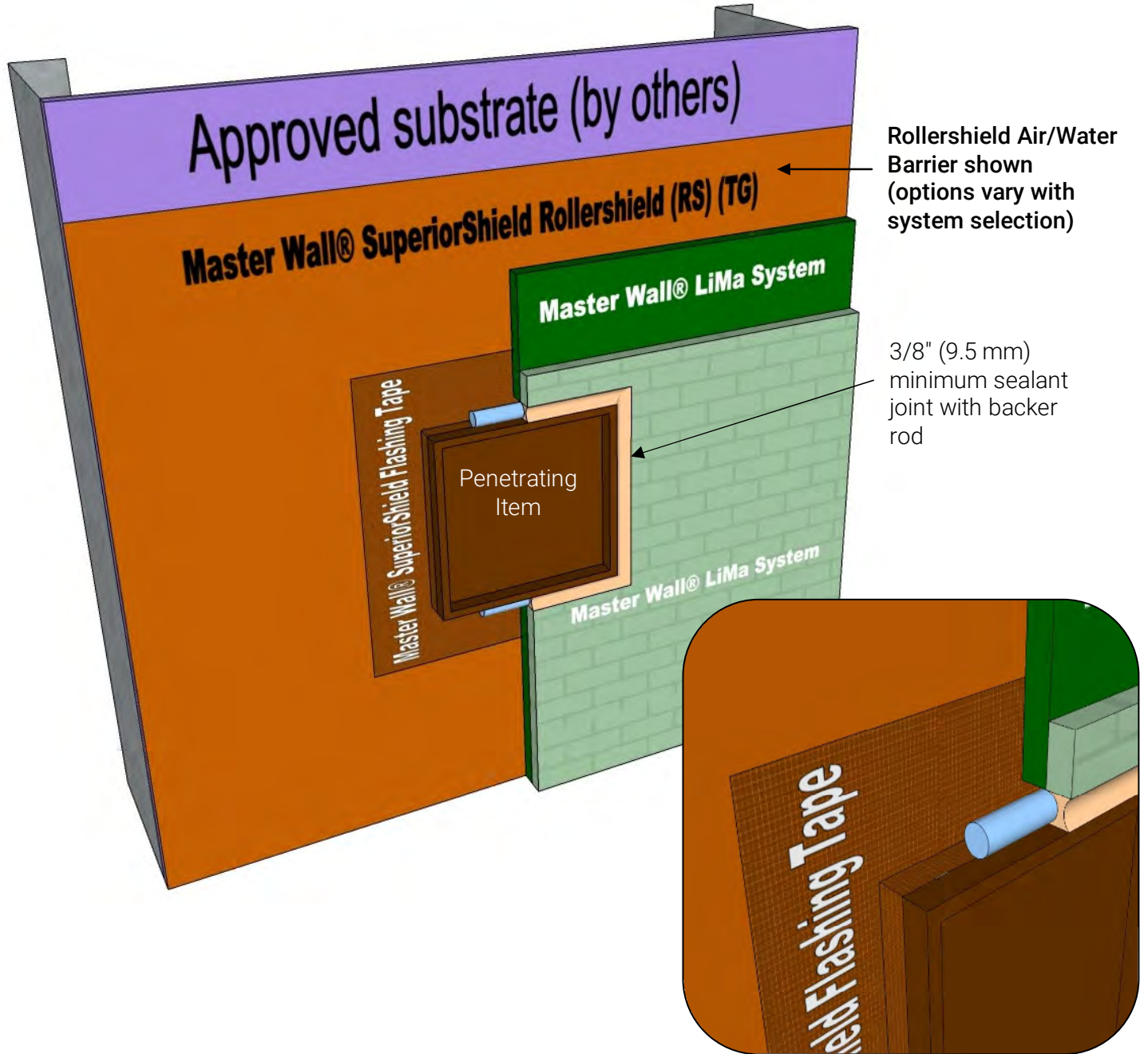

### **LiMa D-07 LiMa to Wall Penetration Detail**

These drawings relay the conceptual conditions of Master Wall® Systems and are not the construction drawings. Ultimately the design and detailing of an entire wall system is the responsibility of a professional. These details will guide the design professional in the use of Master Wall® Products. Master Wall disclaims design, warranty or construction intent or responsibility. **Bold or Trade Name = Master Wall® Product.** ©2020 Master Wall Inc.®

## System Detail

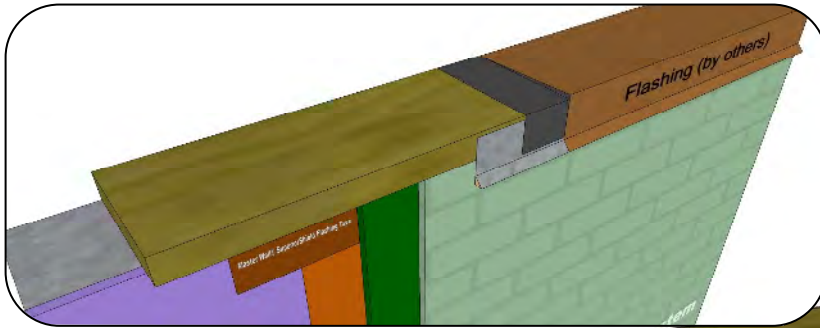

Parapet cap, secondary protection and continuous cleat. Extend 2" (51 mm) minimum over the system and seal lower edge.

Rollershield Air/Water Barrier shown (options vary with system selection)

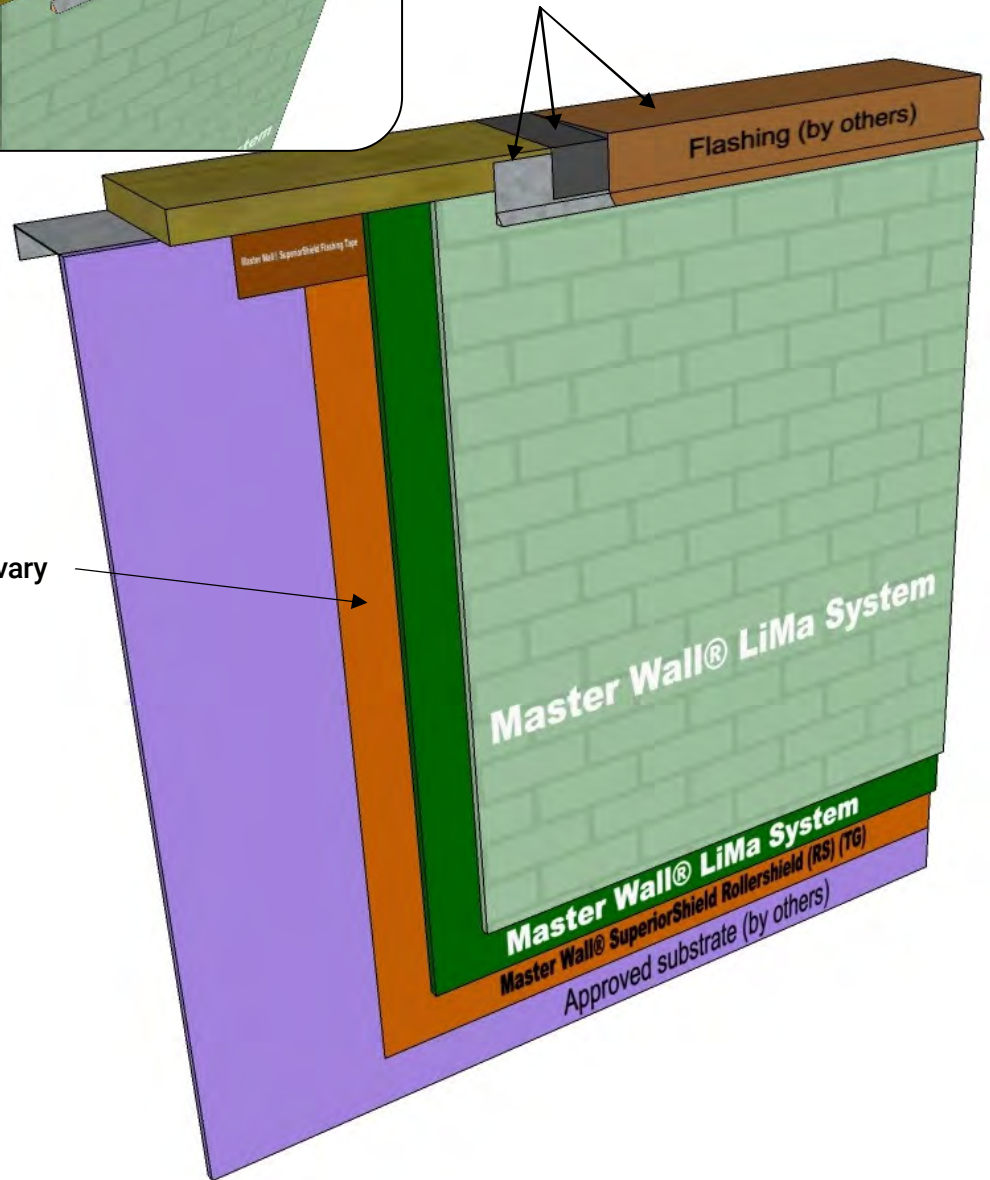

### ***LiMa D-08 Parapet Cap Detail***

These drawings relay the conceptual conditions of Master Wall® Systems and are not the construction drawings. Ultimately the design and detailing of an entire wall system is the responsibility of a professional. These details will guide the design professional in the use of Master Wall® Products. Master Wall disclaims design, warranty or construction intent or responsibility. **Bold or Trade Name = Master Wall® Product.**



# System Detail

WeatherStop Tape shown @ substrate expansion joint

- Rollershield with Rollershield Flashing Tape and backing
- SuperiorFlash with backing Option

Rollershield Air/Water Barrier shown (options vary with system selection)

Sealant joint and backer rod sized for anticipated movement, 3/8" (9.5 mm) minimum

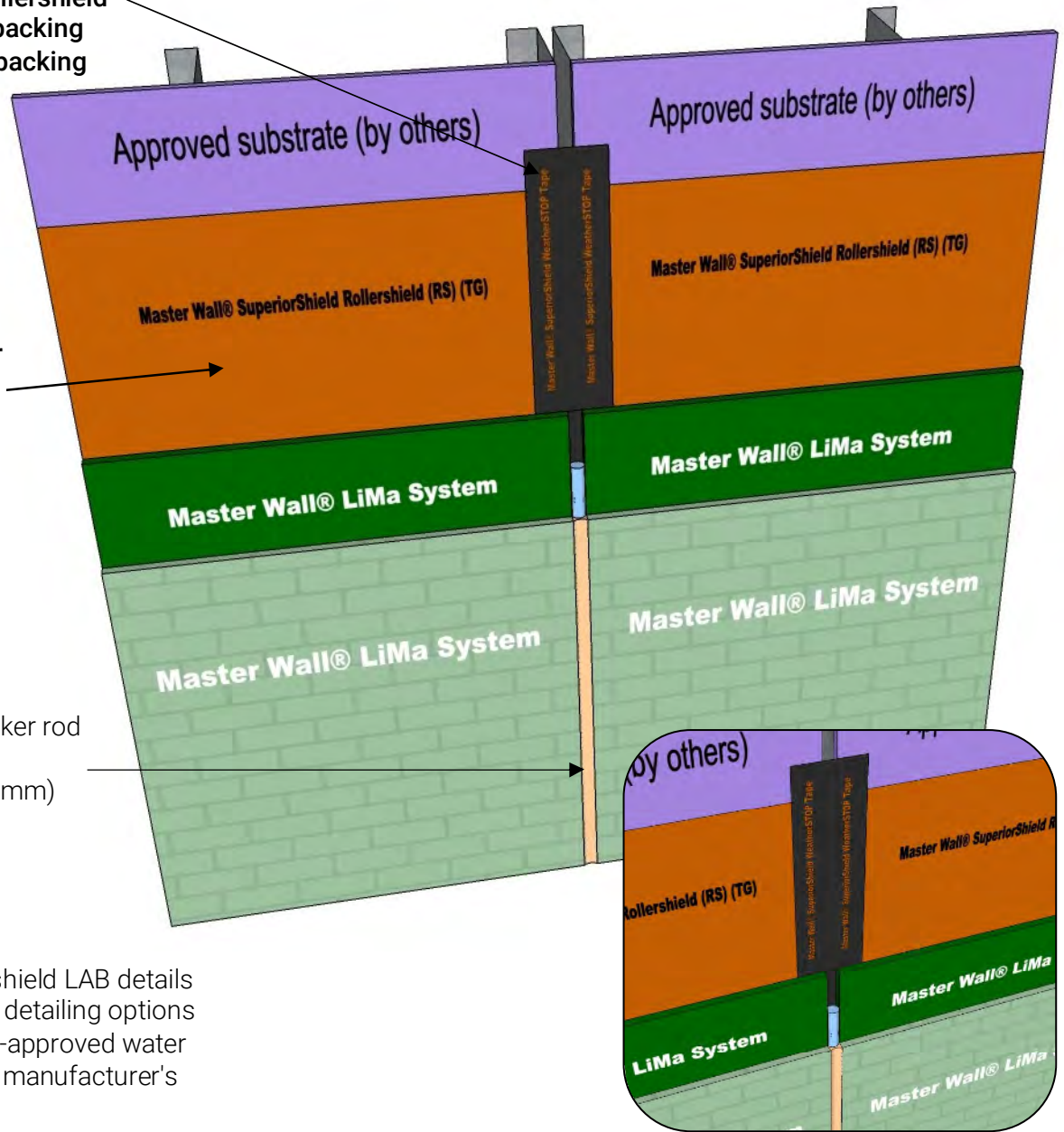

Notes:

- See the Rollershield LAB details for a full set of detailing options
- For other code-approved water barriers follow manufacturer's instructions

## ***LiMa D-09 Expansion Joint Detail***

These drawings relay the conceptual conditions of Master Wall® Systems and are not the construction drawings. Ultimately the design and detailing of an entire wall system is the responsibility of a professional. These details will guide the design professional in the use of Master Wall® Products. Master Wall disclaims design, warranty or construction intent or responsibility. **Bold or Trade Name = Master Wall® Product.**

# System Detail

Rollershield Air/Water Barrier shown (options vary with system selection)

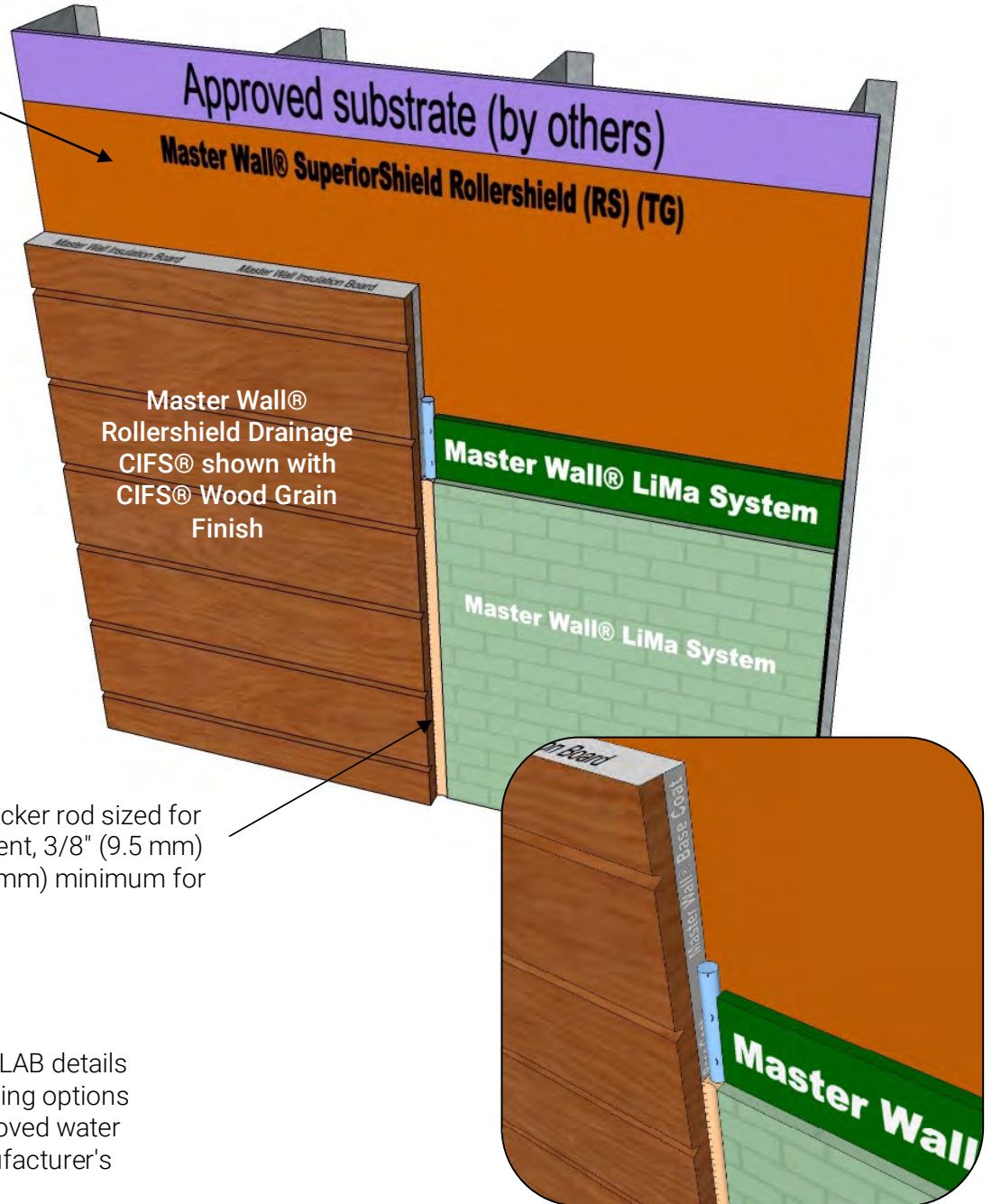

Sealant joint and backer rod sized for anticipated movement, 3/8" (9.5 mm) minimum, 3/4" (19 mm) minimum for CIFS®

Notes:

- See the Rollershield LAB details for a full set of detailing options
- For other code-approved water barriers follow manufacturer's instructions

## ***LiMa D-10 Dissimilar Materials***

These drawings relay the conceptual conditions of Master Wall® Systems and are not the construction drawings. Ultimately the design and detailing of an entire wall system is the responsibility of a professional. These details will guide the design professional in the use of Master Wall® Products. Master Wall disclaims design, warranty or construction intent or responsibility. **Bold or Trade Name = Master Wall® Product.**